



innermost®



innermost®

innogy  
Energy  
East<sup>®</sup>

**With our core belief that ‘light is a material’, we thrive from taking wild ideas and creating beautiful, thoughtful and innovative products.**

**Founded by Steve Jones and Russell Cameron in London in 1999, we continue to work with exciting designers from all over the world to craft a contemporary lighting collection of the absolute highest quality. With an instinctive desire to rebel from the norm, we utilise materials and processes in unique ways to defy expectation.**

**Innermost products speak of craftsmanship as we design everything with longevity in mind. We are as ‘British as London itself’: an incongruous mixture of classic English tradition and vibrant global diversity.**











# Content



**Panel**  
14-19



**Beads**  
20-25



**Facet**  
26-33



**Facet Wall**  
34-35



**Brixton Spot**  
36-39



**Brixton Spot Cluster**  
40-43



**Brixton Wall**  
44-45



**Brixton Adj Wall**  
46-47



**Membrane**  
48-53



**Buckle**  
54-59



**Doric**  
60-65



**Matrioshka**  
66-69



**Lateralis**  
70-73



**Bramah  
Pendant**  
74-77



**Bramah  
Table**  
78-79



**Bramah  
Wall**  
80-81



**Bramah  
Bedside**  
82-83



**Bramah  
Floor**  
84-85



**Joseph  
Pendant**  
86-89



**Joseph  
Table**  
90-91



**Joseph  
Wall**  
92-93



**Joseph  
Bedside**  
94-95



**Joseph  
Floor**  
96-97



**Dub**  
98-101



**Radiate**  
102-103

**Large and Luxury**

**The Large & Luxury collection is a wonderful mix of technology and vibrant new aesthetics, where we really go all out to wow. Crafting the highest quality materials, hand-blown glass and striking metallics into contemporary lighting forms. This range speaks of craftsmanship and innovation; an ideal centrepiece for the luxury interior.**

**Combining innovative design with sublime finishes, these unique chandeliers and pendants create stunning and practical installations. Having graced the interiors of 5 star hotels, top restaurants and famous casinos, these pieces of scale add glamour to any space.**





# Panel

By Steve Jones

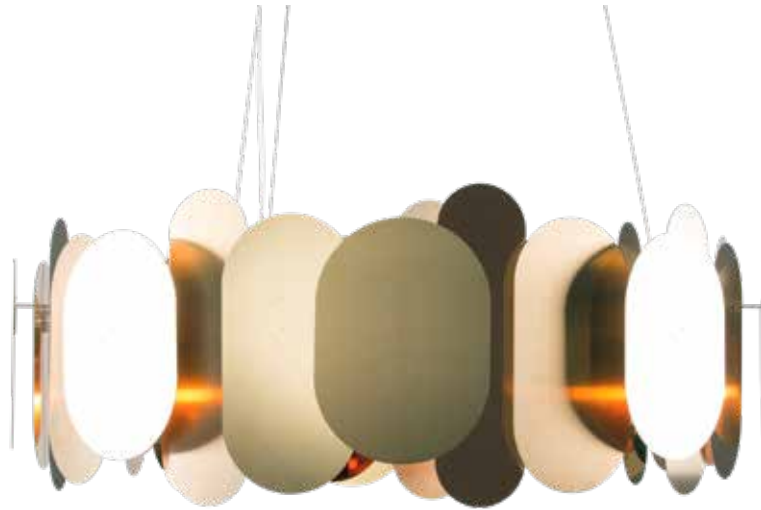

Panel came from experimentation with materials and forms that allowed a mix of finishes. The use of both polished and matt surfaces were inspired by contemporary jewellery as well as architectural metal cladding. Steve Jones layers a mix of finishes and forms to create this exciting chandelier with a contemporary feel.

Panel reflects different sections of the interior it is placed in. A statement piece that is available in a wide range of finishes and colours.





Panel 115 at Decorex



Panel 115 at Private Residence, USA  
Project by DAG Design Group  
Designed by Manuel Frausto

**Panel 75**

Stainless Steel G9 UK/EU: PP07914004 US: PP07934004	Bronze G9 UK/EU: PP07914010 US: PP07934010
---	--

Brass G9 UK/EU: PP07914030 US: PP07934030	Gunmetal G9 UK/EU: PP07914031 US: PP07934031
---	--

Lightsource G9  
12 x G9 Max 5W LED (not included)

Stainless Steel LED UK/EU: PP08914004 US: PP08934004	Bronze LED UK/EU: PP08914010 US: PP08934010
--	---

Brass LED UK/EU: PP08914030 US: PP08934030	Gunmetal LED UK/EU: PP08914031 US: PP08934031
--	---

Lightsource LED  
12 x upward DC integrated 1W LED  
24 x downward DC integrated 1W LED

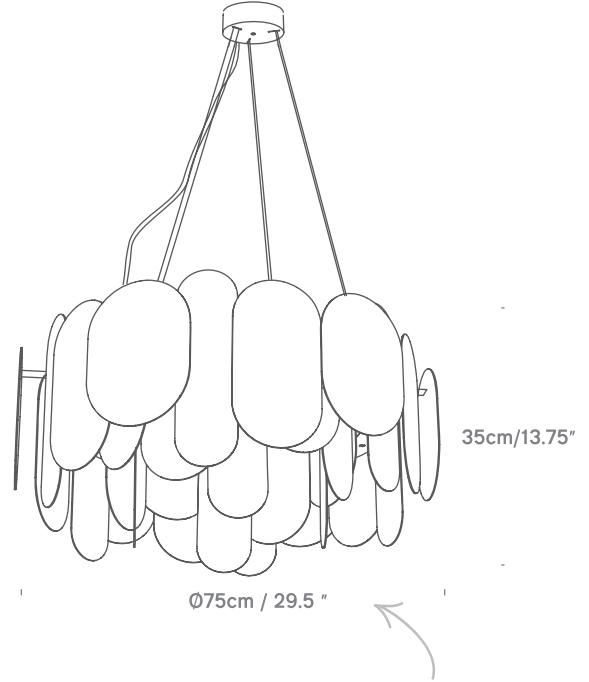

*Polished and brushed panels mounted around the perimeter of the ring allow interesting reflections*

**Panel 115**

Stainless Steel G9 UK/EU: PP07916004 US: PP07936004	Bronze G9 UK/EU: PP07916010 US: PP07936010
---	--

Brass G9 UK/EU: PP07916030 US: PP07936030	Gunmetal G9 UK/EU: PP07916031 US: PP07936031
---	--

Lightsource G9  
24 x G9 Max 5W LED (not included)

Stainless Steel LED UK/EU: PP08916004 US: PP08936004	Bronze LED UK/EU: PP08916010 US: PP08936010
--	---

Brass LED UK/EU: PP08916030 US: PP08936030	Gunmetal LED UK/EU: PP08916031 US: PP08936031
--	---

Lightsource LED  
18 x upward DC integrated 1W LED  
36 x downward DC integrated 1W LED

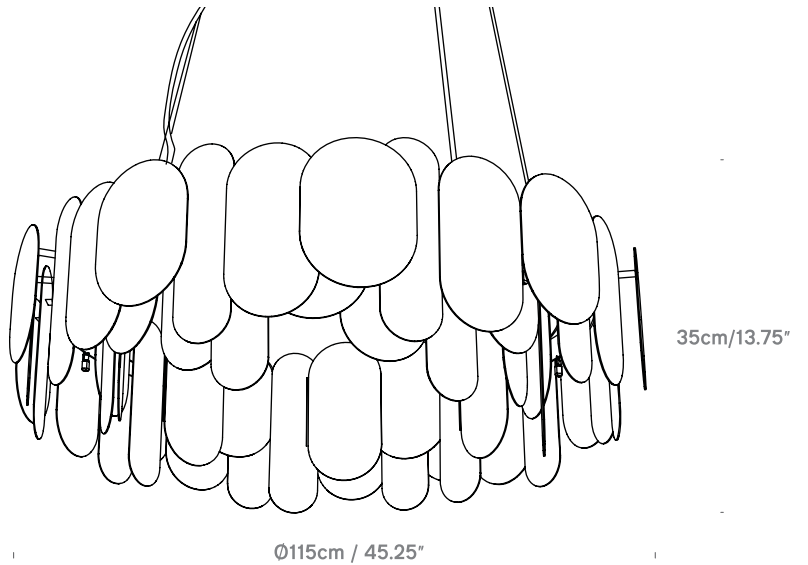

Material	Stainless steel
Colour	Brass/ Bronze / Gunmetal / Stainless Steel
Recommended Bulb	
For G9 version	G9 dimmable bulb up to 500 lumen output and colour temperature from 2200K to 2700K
For LED specs	UK/EU 220v CE certified, USA 120v, integrated 1W AC LED Unit, 900 lumen, 2700K, CRI 80, dimmable via Triac / Lutron chip life 30,000hrs,
Ceiling Rose	Cylindrical, colour matches the product
Cable	4m, clear PVC cable



# Beads

By Winnie Lui



Bringing together the best detailing and finishing from Winnie Lui's jewellery craft and combining it with the engineering and technology of modern lighting design. The results are these striking forms which when lit provide an array of infinite reflections, as if the interior was inlaid with jewels.

The smaller size, Penta, is equal in all dimensions and well suited to smaller narrower spaces. The wider Octo is perfect for large spaces, dining areas, lounges and where maximum impact is needed. Mixing the two shapes together in an installation creates a beautiful effect.



Beads at Harvest Moon, Design by Brooke Turkstra Designs, Burlington, USA



Beads at Akyra Manor Hotel, Chiang Mai, Thailand



Beads at Kensington 2 by Morph Interior, London, UK





Beads at Lincoln Motor Company  
'Black Label-themed' at Miami, USA



Beads at Gaucho,  
by Dining Concepts, Hong Kong



Beads at Firewater Grille, Perth, Australia



Beads at Private Residence, USA



Beads at MS Viking Grace, Fintand

### Beads Penta

Chrome  
UK/EU: PB03914003  
US: PB03934003

Copper  
UK/EU: PB03914007  
US: PB03934007

Gun Metal  
UK/EU: PB03914031  
US: PB03934031

*Penta is equal in all dimensions and well suited to smaller narrower spaces.*

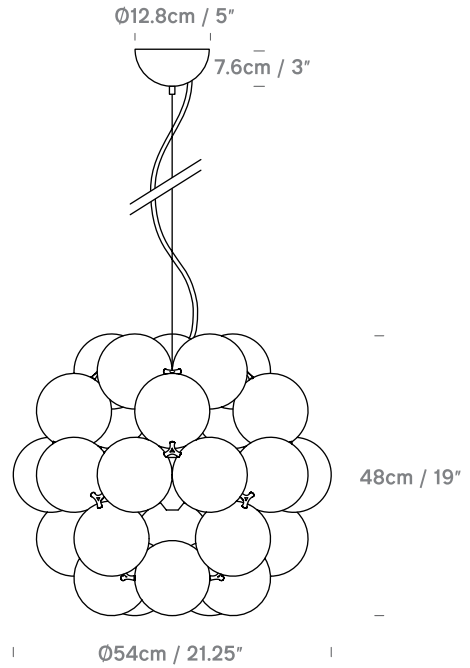

### Beads Octo

Chrome  
UK/EU: PB03915003  
US: PB03935003

Copper  
UK/EU: PB03915007  
US: PB03935007

Gun Metal  
UK/EU: PB03915031  
US: PB03935031

*Beads produces an infinite amount of reflections*

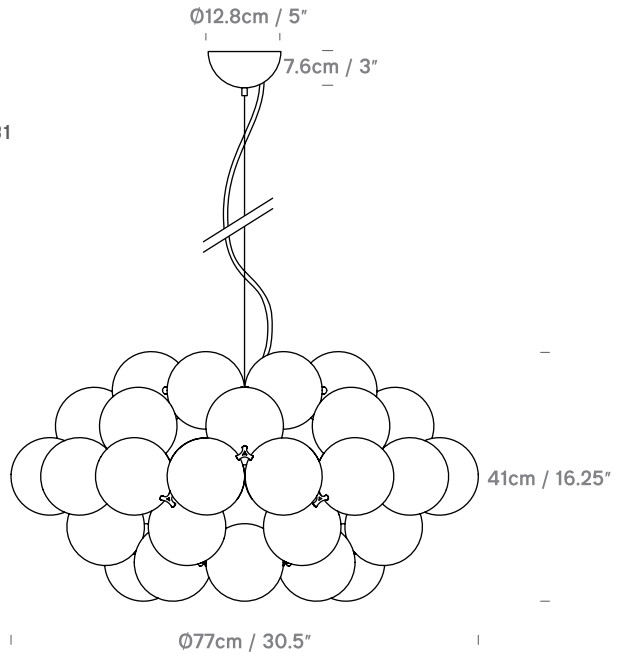

Material  
Colour  
Lightsource  
Recommended Bulb

Stainless steel, polycarbonate  
Copper / Chrome / Gunmetal  
UK/EU E27 Max 15W LED, USA Max 15W LED (not included)  
Beads works with a variety of different LED bulbs.  
LED globe bulbs 500 - 800 lumen output and from 2700K - 3000K colour temperature. These styles are particularly effective in the white colour and in the metallic options for a softer less reflective look.  
LED filament style bulbs will bring out the reflective qualities of the metallic finishes brilliantly. Best performance would be from 600-900 lumen output with 2200K - 2700K colour temperature

Ceiling Rose  
Cable

Hemisphere. Colour matches the product  
4m, clear PVC cable





# Facet

By Tom Kirk



This highly polished stainless steel chandelier & pendant light brings an infinite amount of reflections to any interior. Hundreds of etched and folded strips arrayed around its circumference create a surface of small facets, each presenting part of a fragmented image of the interior space.

The effect often fools the eye into thinking you are looking at glass or crystal until you get closer and realise it is perfectly polished metal. Facet has graced numerous interiors worldwide, as a unique and stunning centrepiece.

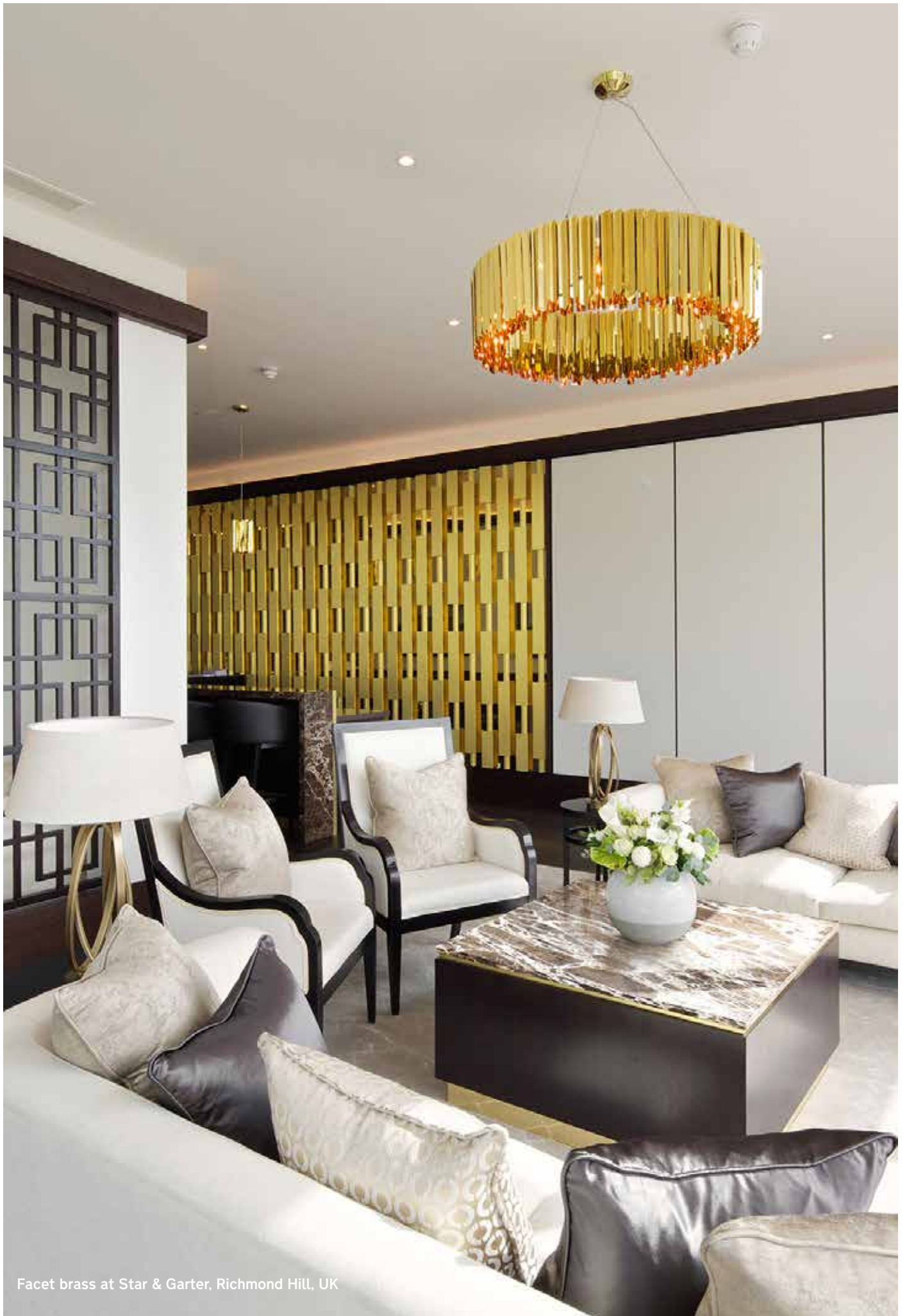

Facet brass at Star & Garter, Richmond Hill, UK

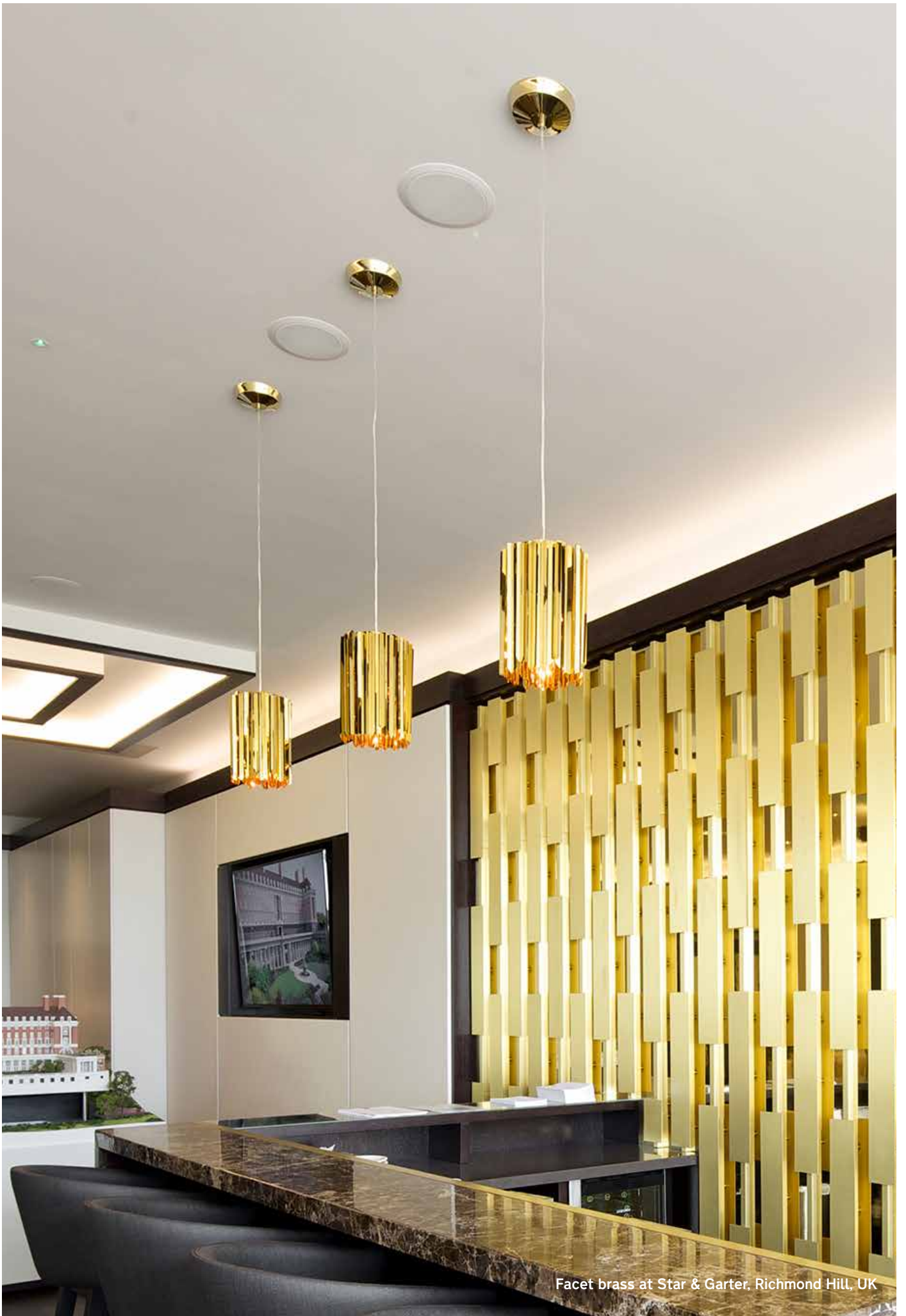

Facet brass at Star & Garter, Richmond Hill, UK



Facet 18 at Private Residence Germany Kreativhaus Wilgmann







Facet at Furla Flagship Store, Regent Street, London, UK

**Facet 18**

Stainless steel  
UK/EU: PF03911003  
US: PF03931003

Brass  
UK/EU: PF03911030  
US: PF03931030

Bronze  
UK/EU: PF03911010  
US: PF03931010

Lightsource  
UK/EU G9 Max 5W LED (not included)  
USA G9 Max 5W LED (not included)

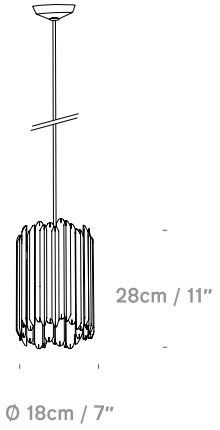

**Facet 60**

Stainless steel  
UK/EU: PF03914003  
US: PF03934003

Brass  
UK/EU: PF03914030  
US: PF03934030

Bronze  
UK/EU: PF03914010  
US: PF03934010

Lightsource  
UK/EU 12x G9 Max 5W LED (not included)  
USA 12x G9 Max 5W LED (not included)

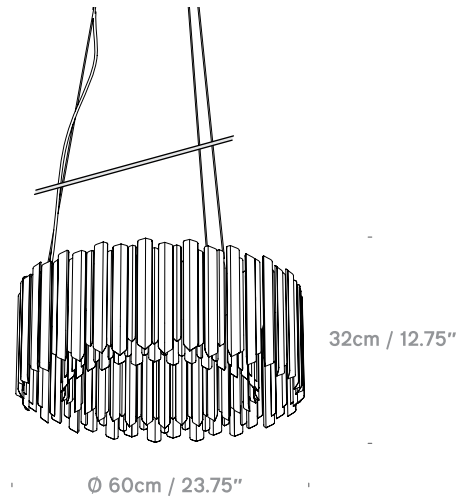

**Facet 100**

Stainless steel  
UK/EU: PF03916003  
US: PF03936003

Brass  
UK/EU: PF03916030  
US: PF03936030

Bronze  
UK/EU: PF03916010  
US: PF03936010

Lightsource  
UK/EU 24x G9 Max 5W LED (not included)  
USA 24x G9 Max 5W LED (not included)

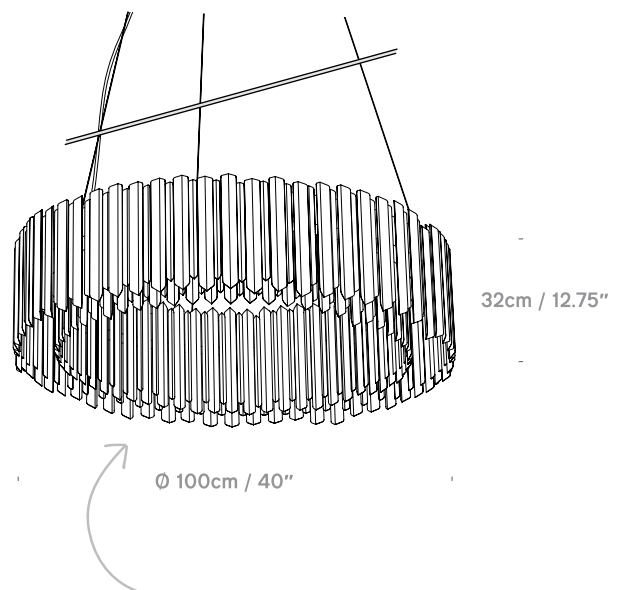

*G9 fittings to give a wide range in illumination options*

### Facet 150

Stainless steel	Brass	Bronze
UK/EU: PF03918003	UK/EU: PF03918030	UK/EU: PF03918010
US: PF03938003	US: PF03938030	US: PF03938010

Lightsource  
 UK/EU 30x G9 Max 5W LED (not included)  
 USA 30x G9 Max 5W LED (not included)

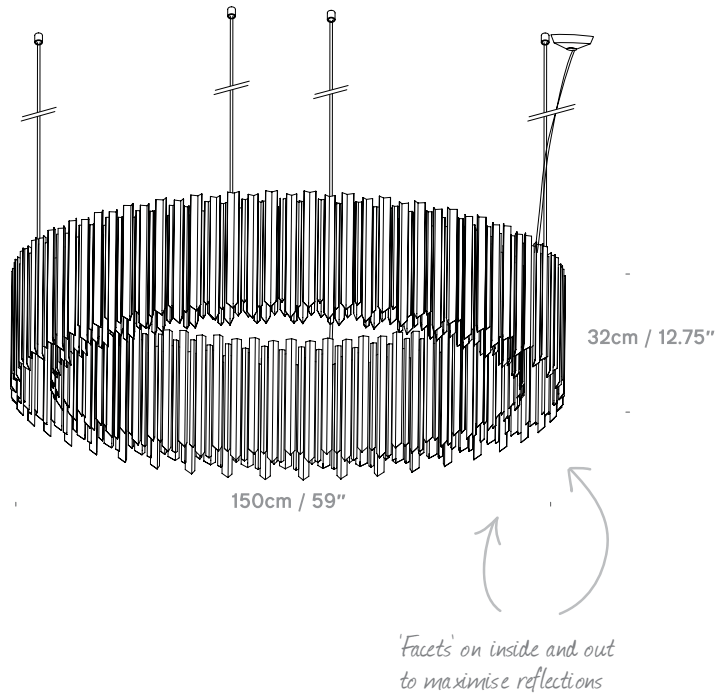

### Facet Lozenge

Stainless steel	Brass	Bronze
UK/EU: PF03916103	UK/EU: PF03916130	UK/EU: PF03916110
US: PF03936103	US: PF03936130	US: PF03936110

Lightsource  
 UK/EU 6x G9 Max 5W LED (not included)  
 USA 6x G9 Max 5W LED (not included)

*Mirror polished, acid etched facets, available in stainless steel, brass or bronze*

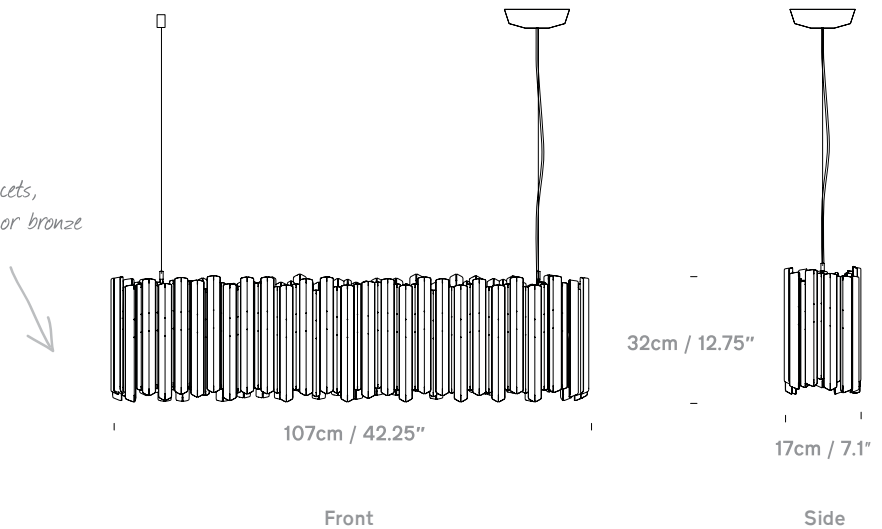

Material	Stainless steel
Colour	Polished Stainless Steel / Polished Brass / Bronze
Recommended Bulb	LED G9 dimmable bulb up to 500 lumen output and colour temperature from 2200K to 2700K
Ceiling Rose	Angled. Colour matches the product
Cable	4m, clear PVC cable



# Facet Wall

By Tom Kirk



Facet Wall Light is an up and down illuminating wall fixture by Tom Kirk for innermost. The acid etched facets are finished in Brass, Stainless steel and Bronze.



Stainless Steel  
 UK/EU: WF03912003  
 US: WF03932003

Brass  
 UK/EU: WF03912030  
 US: WF03932030

Bronze  
 UK/EU: WF03912010  
 US: WF03932010

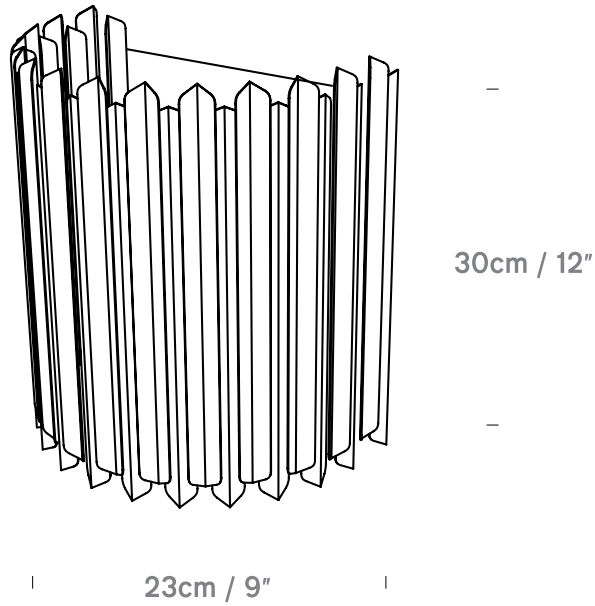

Material	Stainless steel
Colour	Polished Stainless Steel / Polished Brass / Bronze
Lightsource	UK/EU 2x G9 Max 5W LED, USA 2x G9 Max 5W LED (not included)
Recommended Bulb	2x G9 LED bulb up to 500 lumen output, dimmable. Temperature 2200K - 2700K
Projection From Wall	16cm / 6.5"



# Brixton Spot

By James Bartlett



Brixton is a spot pendant inspired by the Victorian railway and residential architecture of south London. Designer James Bartlett took the octagonal turrets that appear on buildings in the area as the starting point for this design, which has a strong engineered aesthetic.

The spot pendants are extremely flexible for a range of installation options, with a solid, industrial feel.



Brixton Spot 20 at Bar 54, China



Brixton Spot 50 at Private Residence, USA



### Brixton Spot 11

White UK/EU: PB09910501 US: PB09930501	Copper UK/EU: PB09910507 US: PB09930507	Graphite UK/EU: PB09910536 US: PB09930536
--	---	---

Lightsource  
DC integrated 6W LED  
UK/EU 220v USA 120v

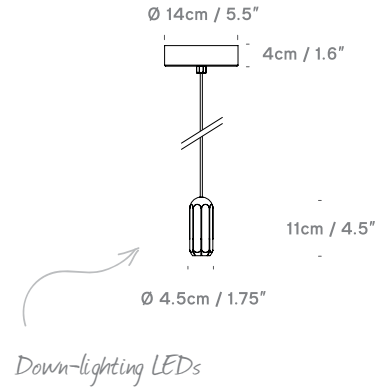

### Brixton Spot 20

White UK/EU: PB09912001 US: PB09932001	Copper UK/EU: PB09912007 US: PB09932007	Graphite UK/EU: PB09912036 US: PB09932036
--	---	---

Lightsource  
DC integrated 8W LED  
UK/EU 220v USA 120v

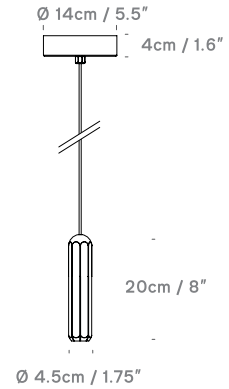

### Brixton Spot 50

White UK/EU: PB09915001 US: PB09935001	Copper UK/EU: PB09915007 US: PB09935007	Graphite UK/EU: PB09915036 US: PB09935036
--	---	---

Lightsource  
DC integrated 8W LED  
UK/EU 220v USA 120v

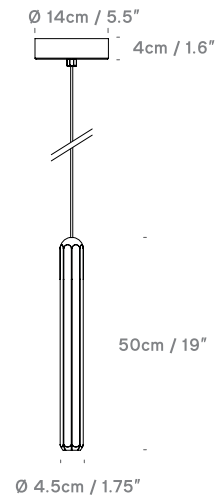

Material	Aluminium and stainless steel
Colour	White / Copper / Graphite
Lightsource	UK/EU 220v USA 120v, integrated 6/8W LED 400/600 lumen, 3000K, CRI 90, Triac / Lutron dimmable, CE/ETL certified.
Ceiling Rose	White / copper / black cylindrical
Cable	4m. White - white matt PVC Copper and Graphite- black matt PVC





# Brixton Spot Cluster

By James Bartlett

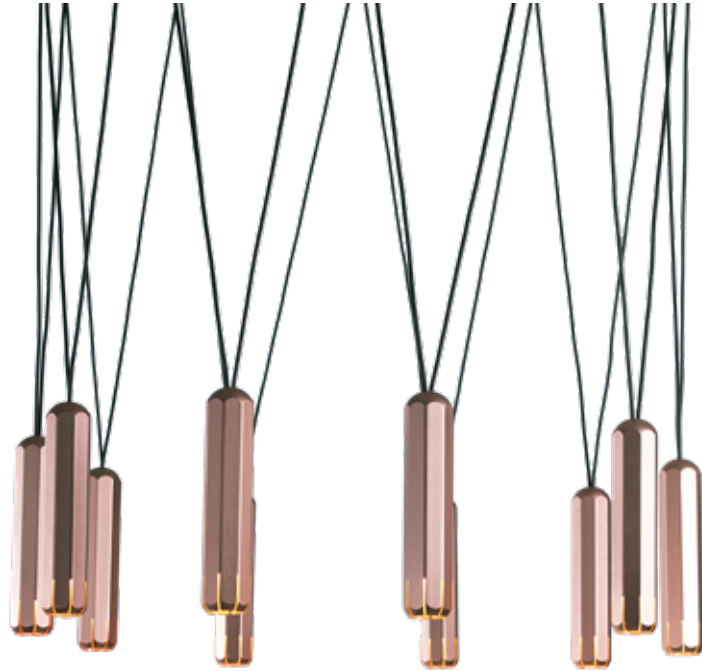

In the Spot Cluster, Brixton pendants are suspended around a circular disk. The clusters can be arranged in various patterns to give different design options. Arranged as a down-lit cluster chandelier, the cords themselves criss-cross to create decorative geometric patterns.

**Brixton Cluster** can be installed with many different configuration options depending on the installation.



White  
UK/EU: PB12915001  
US: PB12935001

Copper  
UK/EU: PB12915007  
US: PB12935007

Graphite  
UK/EU: PB12915036  
US: PB12935036

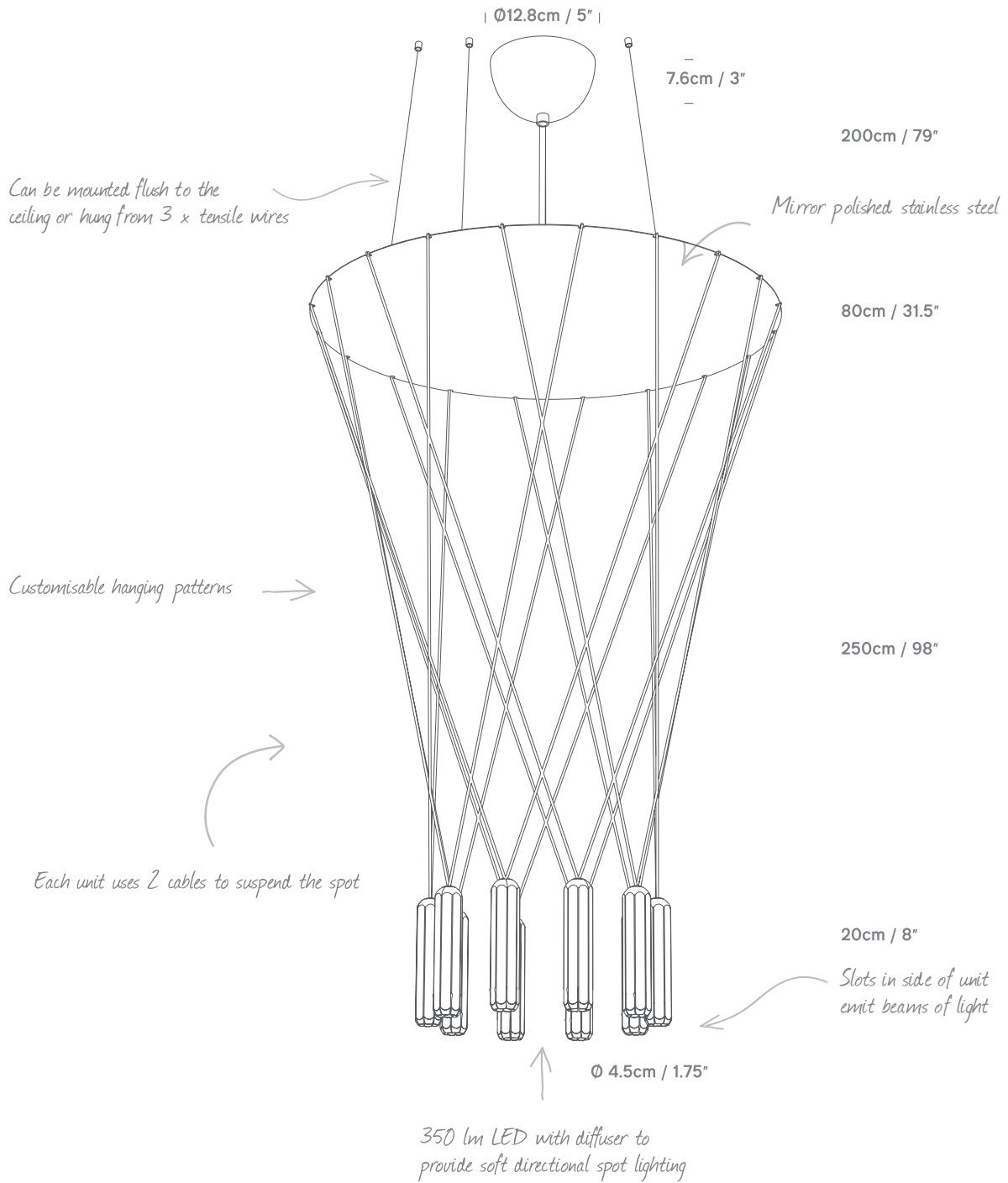

Material	Aluminium and stainless steel
Colour	White/ Copper /Graphite
Lightsource	10x DC integrated 8W LED UK/EU 220v USA 120v 350 lumen, 3000K, CRI 90, Triac / Lutron Dimmable, CE / ETL certified.
Ceiling Rose	White cylindrical
Cable	4m. White - white matt PVC Copper and Graphite- black matt PVC



# Brixton Wall

By James Bartlett



Brixton Wall is a classic up-lighter mounted on an aluminium wall plate, and available in copper or graphite.

Copper  
 UK/EU: WB10810507  
 US: WB10830507

Graphite  
 UK/EU: WB10810536  
 US: WB10830536

*Castellations provide interesting shadows on the back panel*



11cm / 4.5"

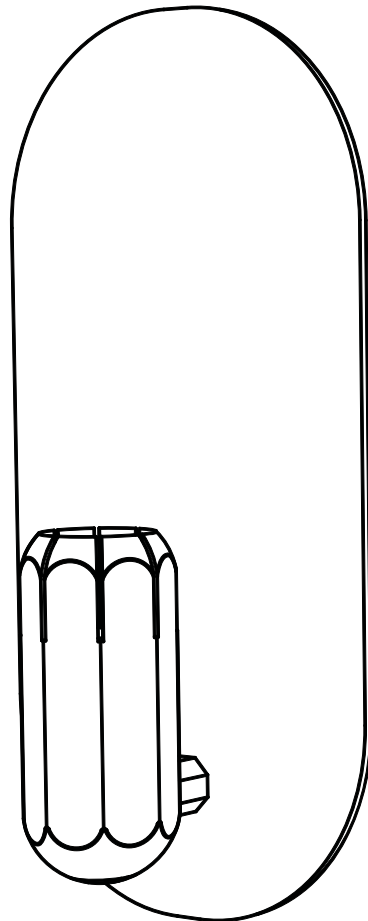

30cm / 12"



*Two assembly options- Compact with the driver installed in the wall or with the driver in the product*

15cm / 6"

Material	Aluminium
Colour	Copper / Graphite
Lightsource	UK/EU 220v USA 120v, integrated 6W LED 375 lumen, 2700K, CRI 90, Triac / Lutron dimmable, CE/ETL certified.
Projection From Wall	9.5cm / 3.75" or 8cm / 3.25"



# Brixton Adj Wall

By James Bartlett



This classic down-lighter is mounted on an aluminium wall plate, and is adjustable so that the light focus can be directed. Extra features added to this bedside design include front switch, adjustable head and a USB for device charging. Brixton Adjustable Wall is available in copper or graphite.



Copper  
 UK/EU: WB16810507  
 US: WB16830507

Graphite  
 UK/EU: WB16810536  
 US: WB16830536

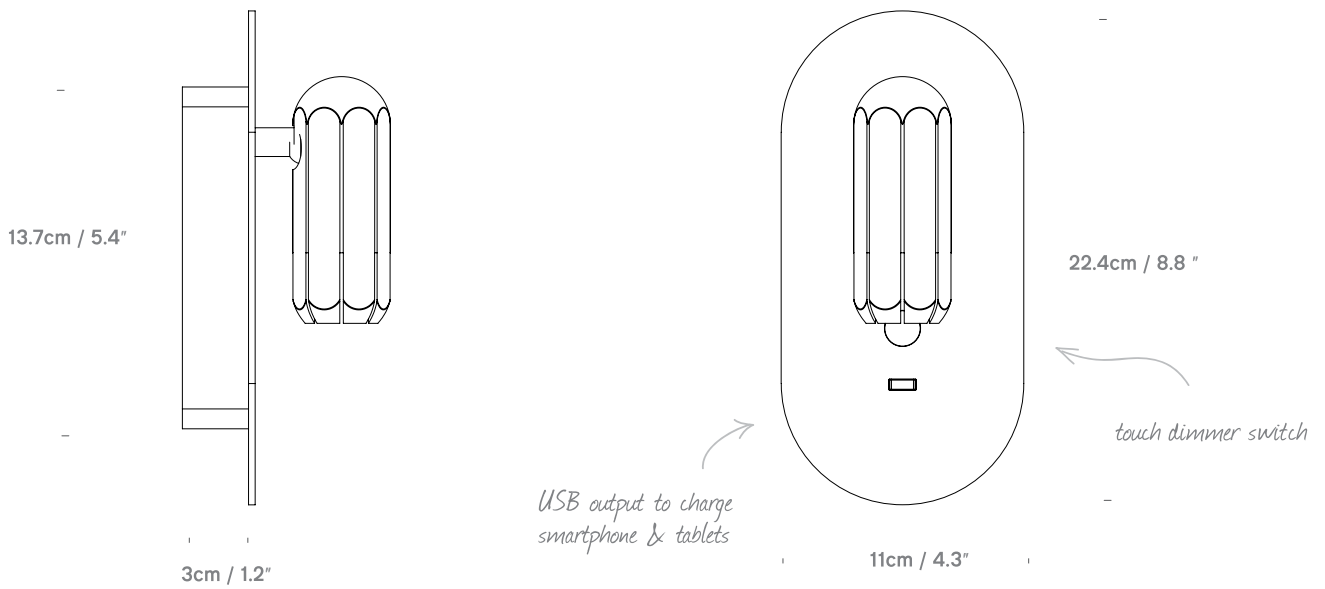

Material	Aluminium and Steel
Colour	Copper / Graphite
Lightsource	Integrated LED Source, CREE LED, chip life 40,000 hours, 2.5W, 200lm, 2700K, CRI (Ra) 80, Beam Angle 160°
Projection From Wall	9.4cm / 3.7"
Other	Universal Driver, USB Charger 5V 2mA, touch dimmer switch.



# Membrane

By Jette Scheib



Membrane's smoky hand-blown glass body seems to cool and harden at the precise moment bulb and shade become one, forever encapsulating the light sources. Strikingly beautiful, the translucent glass has been seemingly pierced by light bulbs, leaving only the fittings and cable exposed.

The skills of the Czech Glass craftsmen are immediately evident in this beautiful piece. It takes 4 men several hours to form each piece; hot heavy work that requires the most skilled craftsmen. Polished gunmetal fittings result in a sophisticated design well.



Membrane in Steelhouse Copenhagen, Denmark



Membrane at Private Residence Germany  
Designed by Kreativhaus Wilgmann



Membrane at innemrost USA house



Membrane at Private Residence, Norway



UK/EU: PM09913005  
 US: PM09933005

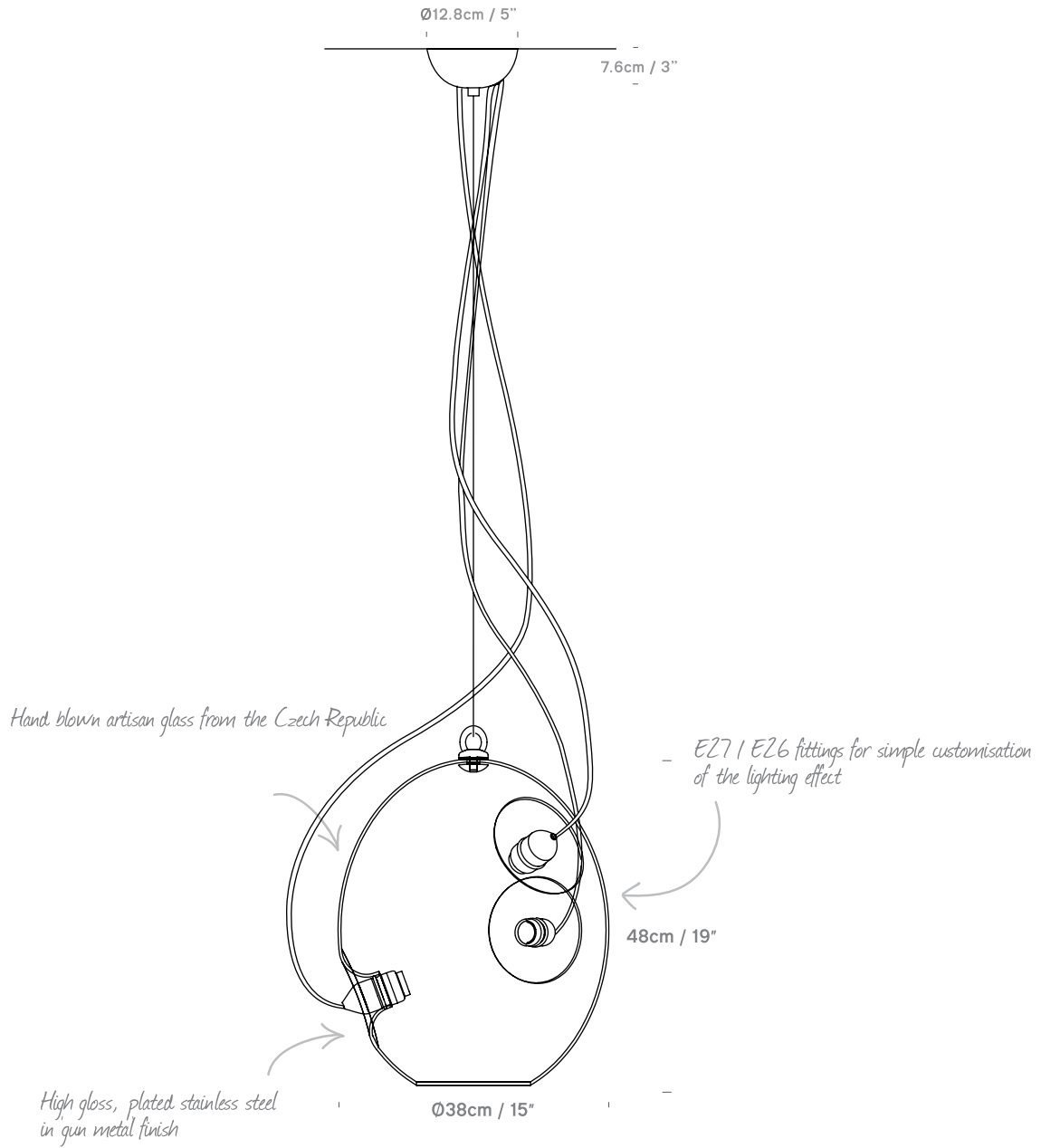

Material	Glass and aluminium
Colour	Smoke glass with gunmetal fittings
Lightsources	UK/EU 3x E27 Max 15W LED each, USA 3x E26 Max 15W LED each (not included)
Recommended Bulb	Filament or peal LED globe dimmable bulbs 300 - 500 lumen output and colour temperature 2700K
Ceiling Rose	Gunmetal hemisphere
Cable	4m. Black PVC cable







# Buckle

By Tina Leung

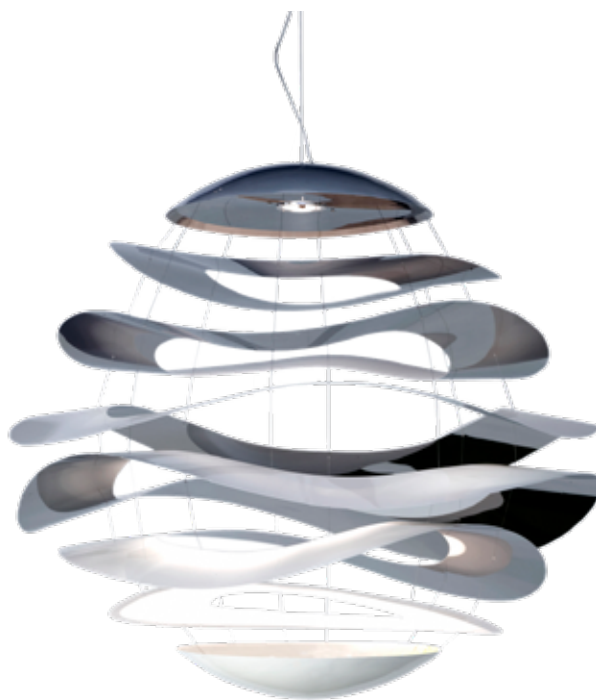

Buckle is a stainless steel pendant light and ambient lighting sculpture. It illuminates by bouncing light off its own internal surfaces and provides wonderful background light. Available in two sizes, it is neither a classic up or down-lighter but produces a unique effect all of its own, casting interesting shadows and reflections. The feeling it creates has often been likened to light bouncing off water and gives a dramatic contrast in interesting spaces.

The scale of the product makes it well suited to high atrium spaces and the low power LED unit makes it low maintenance.



Buckle at Gaucho Restaurant, Dubai

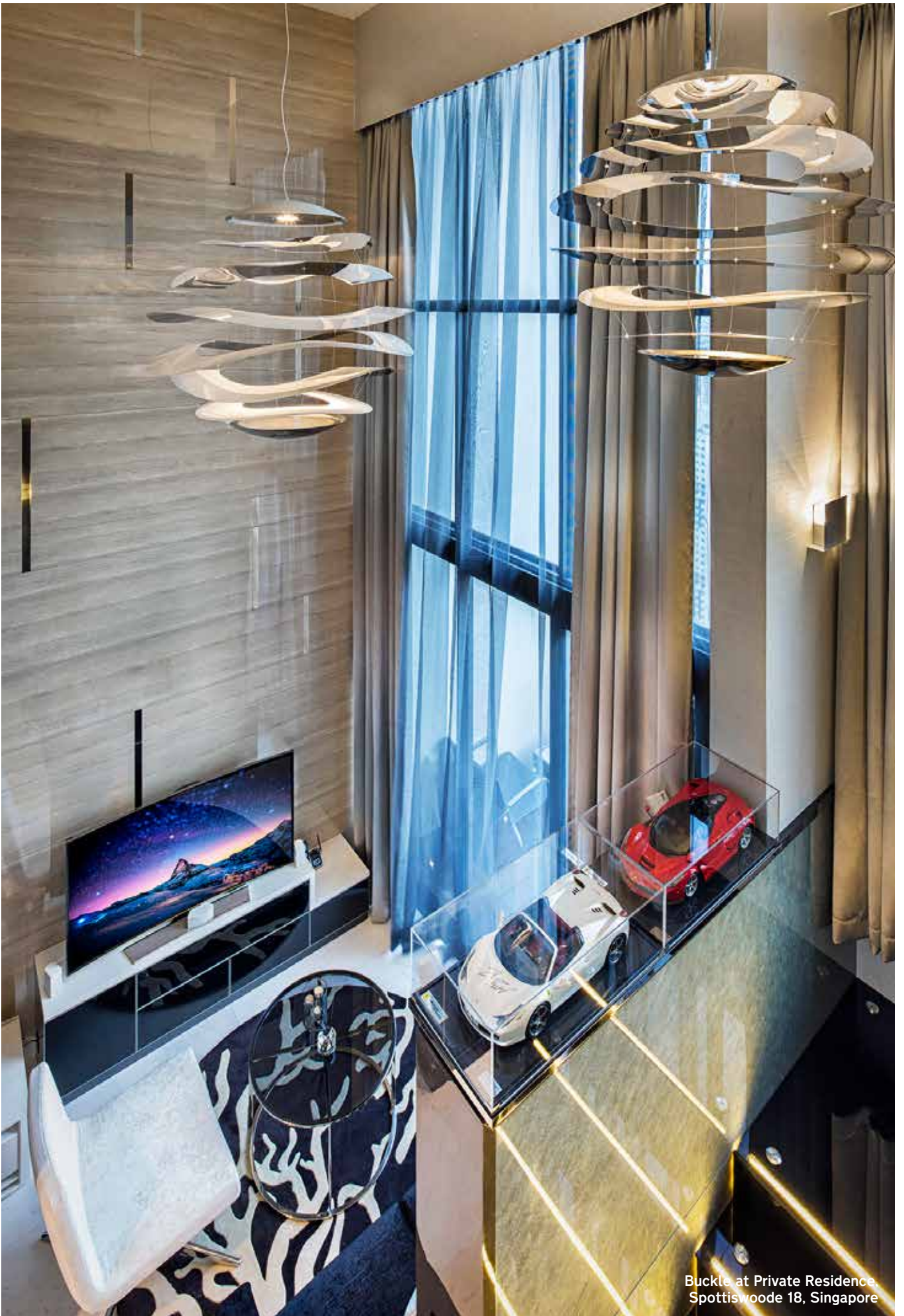

Buckle at Private Residence,  
Spottiswoode 18, Singapore

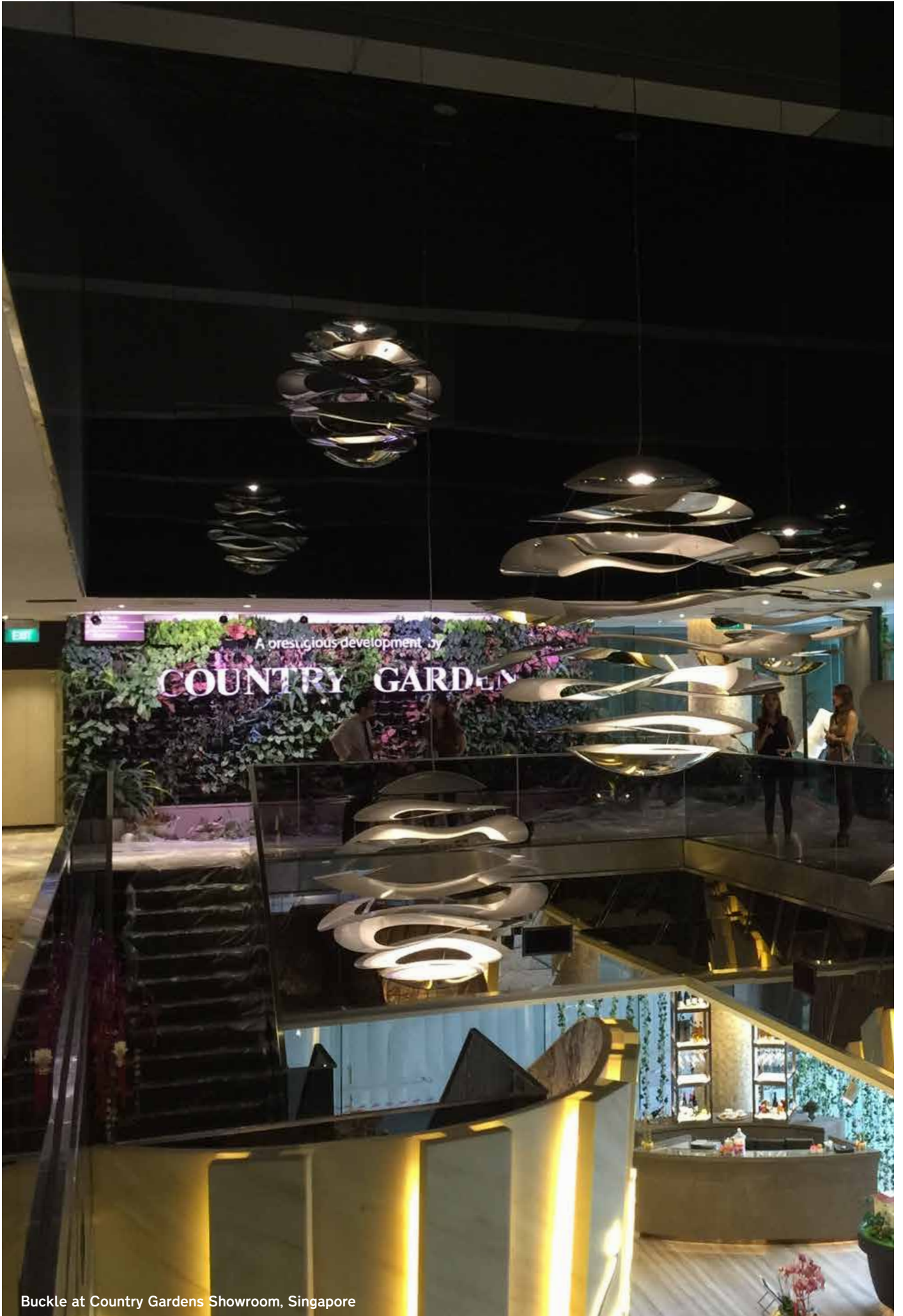

Buckle at Country Gardens Showroom, Singapore

**Buckle 70**

UK/EU: PB04914504  
 US: PB04934504

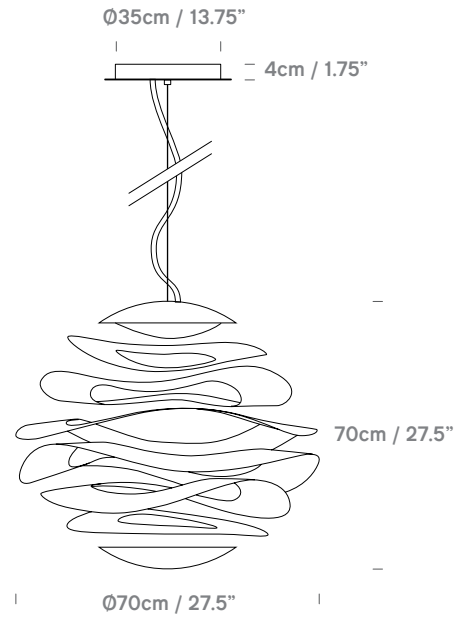

**Buckle 120**

UK/EU: PB04917004  
 US: PB04937004

*Dimmable LED driver located in the ceiling rose*

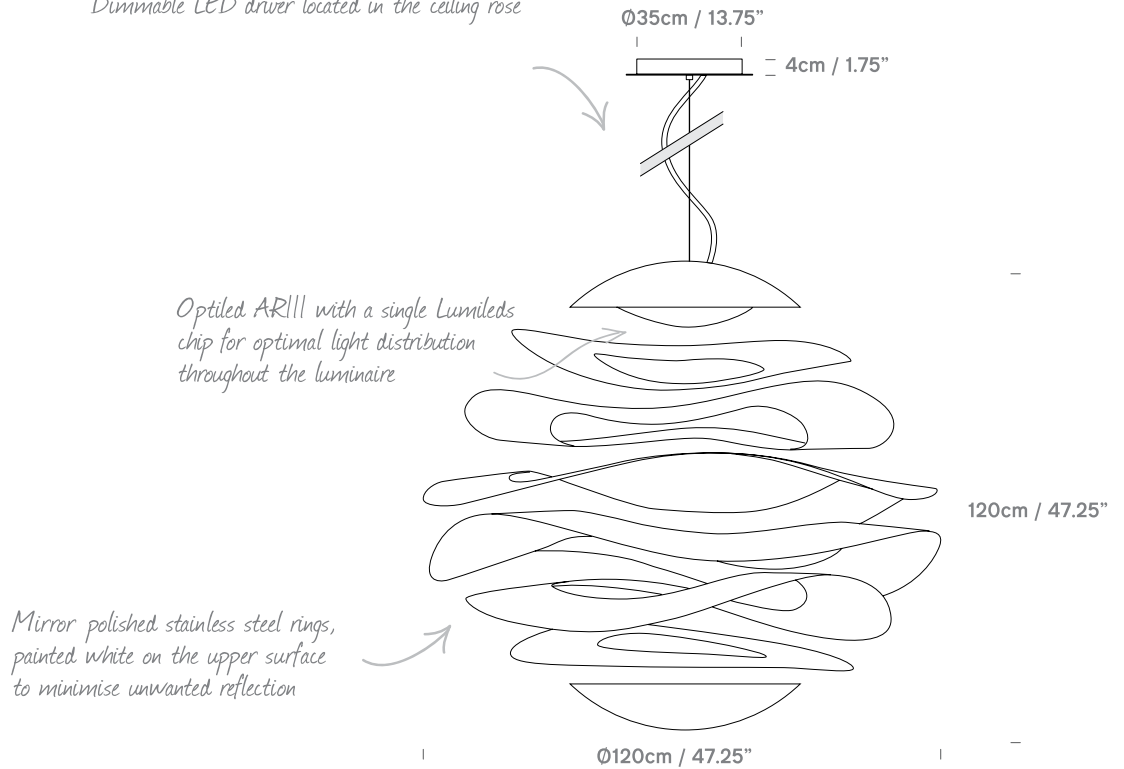

Material	Stainless steel
Colour	Polished Steel and White
Lightsource	UK/EU 220v USA 120v, integrated optiled AR111 15.5W LED, 800 lumen 2800K CRI 80, Lumileds chip, chip life 35,000 hours, beam angle 20° UK/EU dimmable via TRIAC dimmer US dimmable via PWM, 0-10v, resistance dimmer
Ceiling Rose	White cylindrical
Cable	7m. White PVC cable





# Doric

By James Bartlett



James Bartlett was inspired by the forms of ancient columns and pillars, particularly those of the ancient Greek order of architecture: Doric. The traditional forms have been subverted so that the classical scalloped details of the structure instead encircle the interior of the shade. This detail can therefore only be seen from certain angles, particularly beautiful when viewed from below, revealing a form that is not unlike the crimped edge of a seashell.

The beautiful marbled material is actually produced from a resin, giving the appearance of a heavy, solid form, that is in fact lightweight and translucent, allowing for a great variety of sizes and finishes. An elegant smooth marble-look is complimented by quality fittings, to give a contemporary and stylish finish.





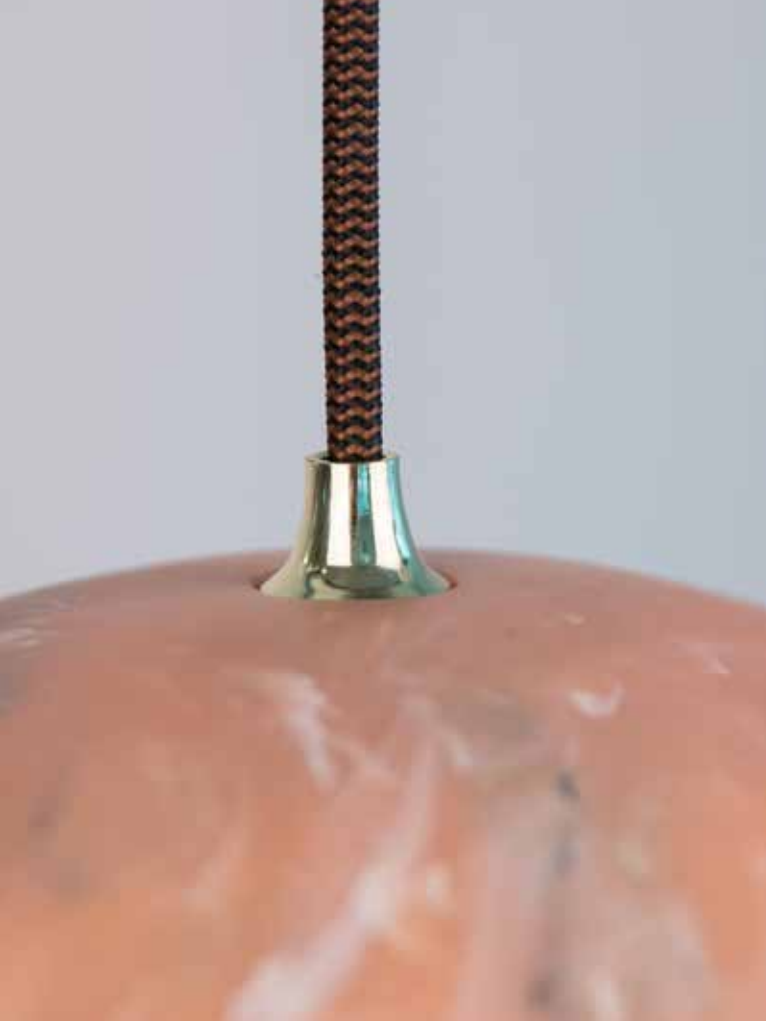



Doric 60 at Private Residence, Canada



Doric 60 at Private Residence, Madrid

### Doric 28

Rose Marble  
UK/EU: PD05912034  
US: PD05932034

White Marble  
UK/EU: PD05912035  
US: PD05932035

Solid Matt White  
UK/EU: PD05912033  
US: PD05932033

Polished Black Marble  
UK/EU: PD05912032  
US: PD05932032

Lightsource  
UK/EU E27 Max 15W LED, USA E26 Max 15W LED (not included)

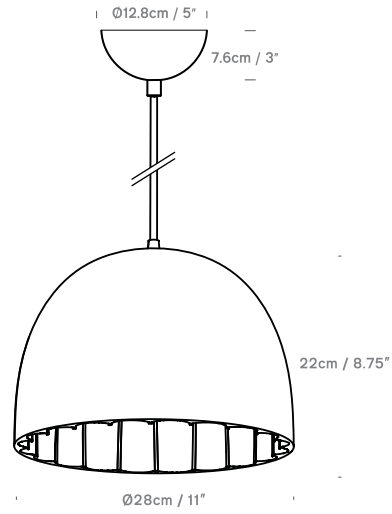

### Doric 60

Rose Marble  
UK/EU: PD05914034  
US: PD05934034

White Marble  
UK/EU: PD05914035  
US: PD05934035

Solid Matt White  
UK/EU: PD05914033  
US: PD05934033

Polished Black Marble  
UK/EU: PD05914032  
US: PD05934032

Lightsource  
UK/EU E27 Max 15W LED, USA E26 Max 15W LED (not included)

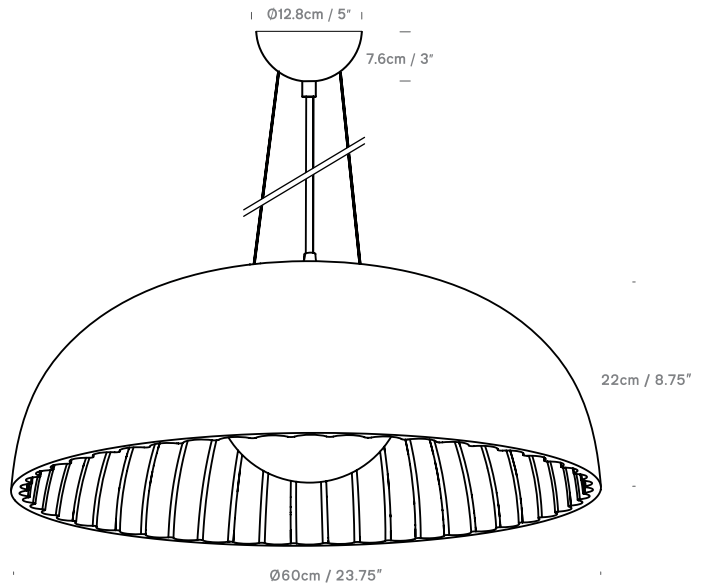

Material	Resin
Colour	Rose Marble / Solid Matt White / White Marble / Polished Black Marble
Recommended Bulb	LED globe bulbs 400 - 1000 lumen output and from 2700K (for warmer with more colour) up to 6000K (daylight)
Ceiling Rose	White Marble and Solid Matt White - White hemisphere Polished Black Marble and Rose Marble - Black hemisphere
Cable	4m. White and Solid Matt White - white braided cable Black - black and white braided cable Rose - black and brown braided cable





# Matrioshka

By Stone Designs



Cast from resin, the individual pieces that make up Stupa are joined and hand finished individually on a lathe, then polished with beeswax. The sharply defined ridges around the design allow different amounts of light through and add to the visual impact of the piece.

The wonderfully unique lighting is made by combining a mass-production process with highly skilled craftsmanship. The result is a lamp that permeates an ambient glowing warmth while still providing a practical light level.

The form was inspired by temple architecture in Asia, particularly the stupas of Myanmar. Winner of Good Design Award 2015.



Matrioshka at YO! Sushi, Tottenham Court Road, London, UK

Grey  
UK/EU: PM0089105  
US: PM089105

Red  
UK/EU: PM089108  
US: PM089308

Blue  
UK/EU: PM089112  
US: PM089312

Yellow  
UK/EU: PM089127  
US: PM089327

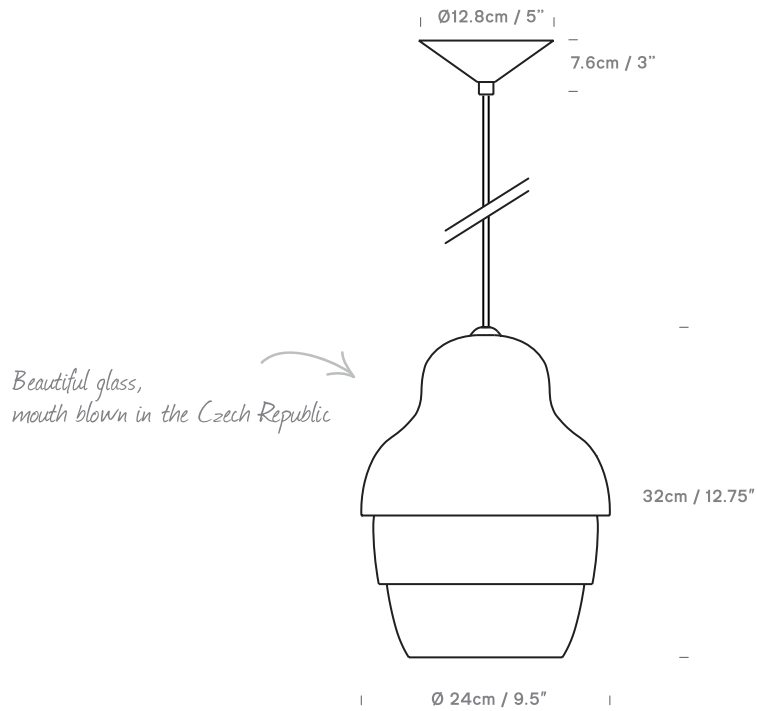

Material	Glass
Colour	Grey / Red / Blue / Yellow
Lightsource	UK/EU E27 Max 15W LED, USA E26 Max 15W LED (not included)
Recommended Bulb	Opal LED globe dimmable bulbs 300 – 500 lumen output and colour temperature 2700K
Ceiling Rose	White conical
Cable	4m. White braided cable

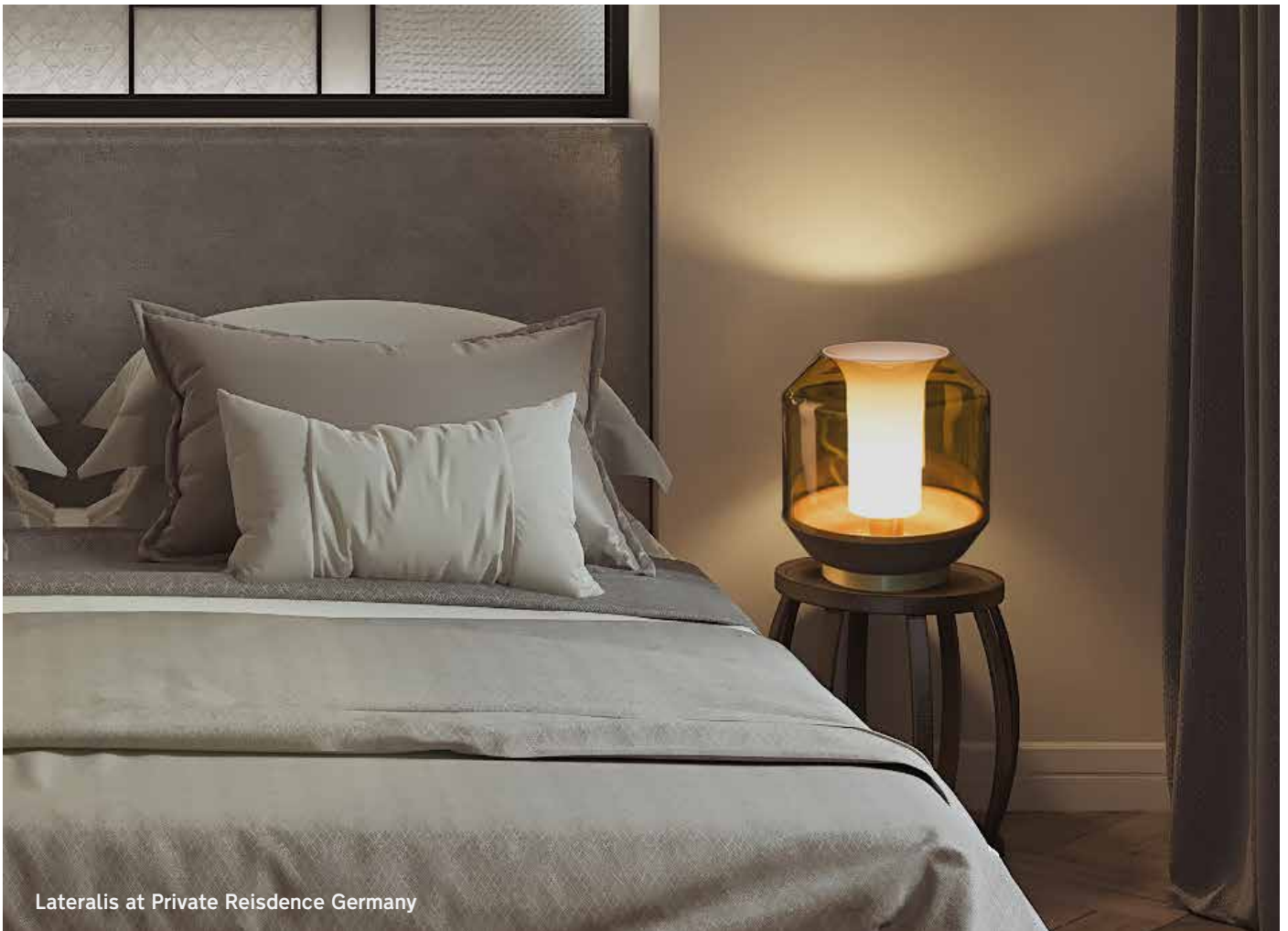

Lateralis at Private Residence Germany



Lateralis at Morgan Furniture Showroom, London, UK



# Lateralis

By Ben McCarthy



Mouth blown glass, turned wood and brass-finish components mix together with a well defined palette in this table lamp. Crafted glass seems to pour upwards and outwards following the breath of the glass blowing artist, producing a honey-coloured dome with a similar syrupy consistency. At the heart of the table light, dark ripples of wood reflect off polished brass.



Lateralis at Private Residence, 28 Aberdeen Street, Sheung Wan, HK



Lateralis at George St. Residence, by Morph Interior, London, UK

UK/EU: LL099127  
US: LL099327

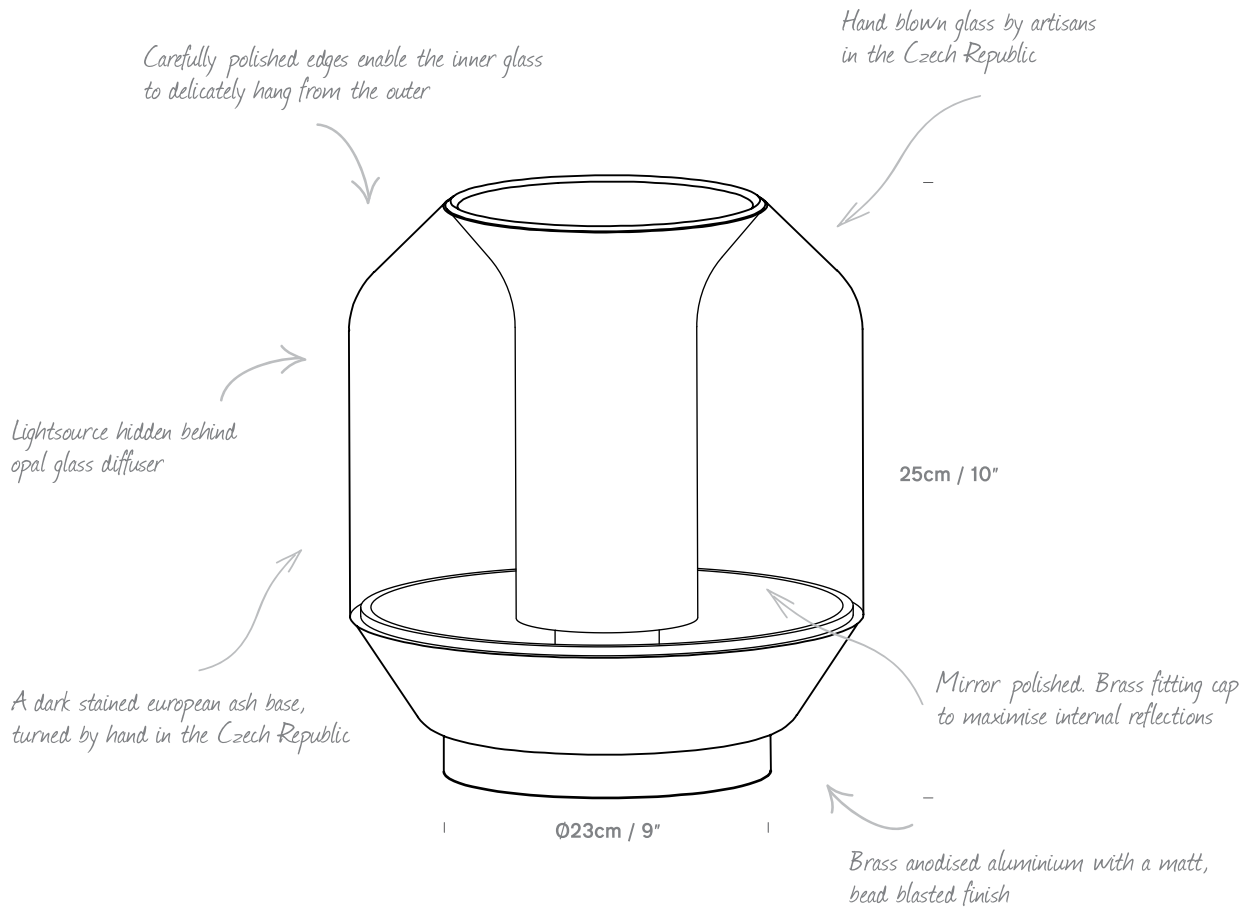

Material	Glass, dark stained ash wood, anodised aluminium
Lightsource	G9 UK/EU Max 5W LED. USA Max 5W LED (not included)
Recommended Bulb	LED G9 dimmable bulb up to 500 lumen output and colour temperature from 2700K to 3000K
Cable	Black braided cable . 30cm to rotary dimmer switch, 80cm to plug.



Bramah Pendant at Gillingwater walk in wardrobe

# Bramah

By Michael Young for EOQ



Bramah represents EOQ's first exploration of lighting forms, which is reflected in the simple and recognisable silhouette. Extruded from a solid block of aluminium, the delicate shadows it creates are both beautiful and surprising.



Bramah Pendants at Bates Smart, Sydney



Bramah Pendant at Sydney Lobby

### Bramah Pendant Small

Pale Gold  
 UK/EU: BMH-13892-SXXXD15  
 US: BMH-14883-SXXXD15

Copper  
 UK/EU: BMH-13892-SXXXD65  
 US: BMH-14883-SXXXD65

Grey  
 UK/EU: BMH-13892-SXXXK55  
 US: BMH-14883-SXXXK55

Lightsource  
 G9 UK/EU: Max 5W LED USA: Max 5W LED

Recommended Bulb  
 Any G9 LED bulb up to 180 - 500 Lumen output,  
 dimmable. Temperature 2200 - 2800 Kelvin

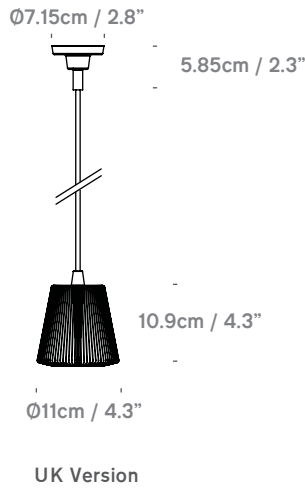

### Bramah Pendant Large

Pale Gold  
 UK/EU: BMH-13893-SXXXD15  
 US: BMH-14882-SXXXD15

Copper  
 UK/EU: BMH-13893-SXXXD65  
 US: BMH-14882-SXXXD65

Grey  
 UK/EU: BMH-13893-SXXXK55  
 US: BMH-14882-SXXXK55

Lightsource  
 UK/EU: E27 Max 15W LED USA: E26 Max 15W LED

Recommended Bulb  
 Filament or Pearl LED Globe bulbs  
 with 300 - 500 Lumen output, 2800 Kelvin

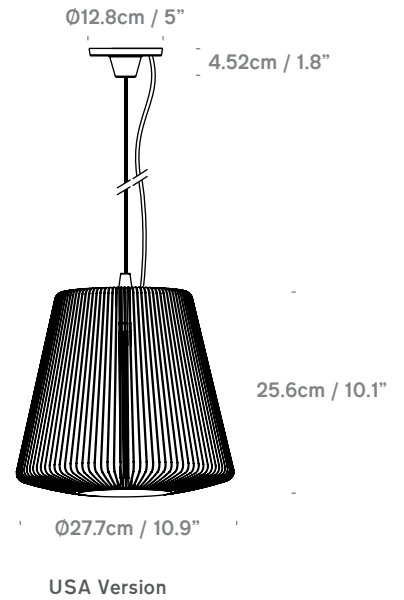
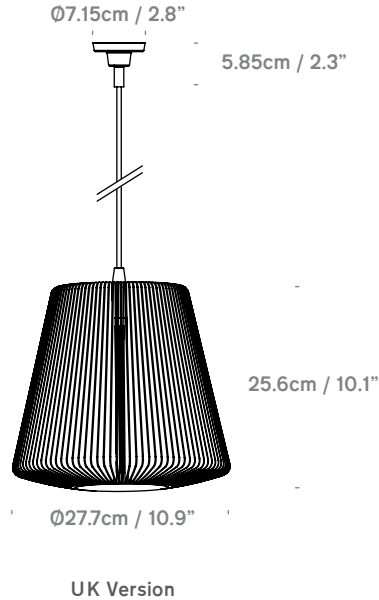

Material	Aluminium
Finish	Anodised
Colour	Copper/ Pale Gold/ Grey
Ceiling Rose	Same colour as shade
Cable	4m / Black braided

# Bramah Table

By Michael Young for EOQ



Bramah Table in Hotel Lobby



Pale Gold  
 UK/EU: BMT-14021-SXXXD15  
 US: BMT-14886-SXXXD15

Copper  
 UK/EU: BMT-14021-SXXXD65  
 US: BMT-14886-SXXXD65

Grey  
 UK/EU: BMT-14021-SXXXK55  
 US: BMT-14886-SXXXK55

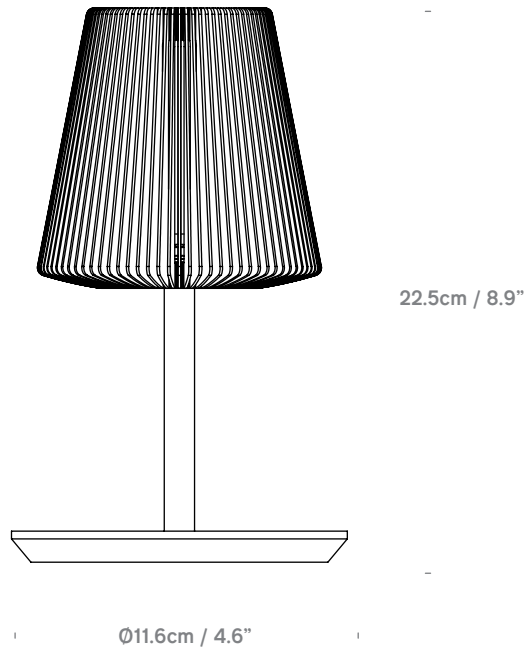

Material	Aluminium
Finish	Anodised
Colour	Copper/ Pale Gold/ Grey
Lightsource	G9 UK/EU: Max 5W LED USA: Max 5W LED
Recommended Bulb	Any G9 LED bulb up to 180 - 500 Lumen output, dimmable. Temperature 2200 - 2800 Kelvin
Cable	28.5cm to switch, 150.5cm to plug / Black Cable
Switch	Inline rocker

# Bramah Wall

By Michael Young for EOQ

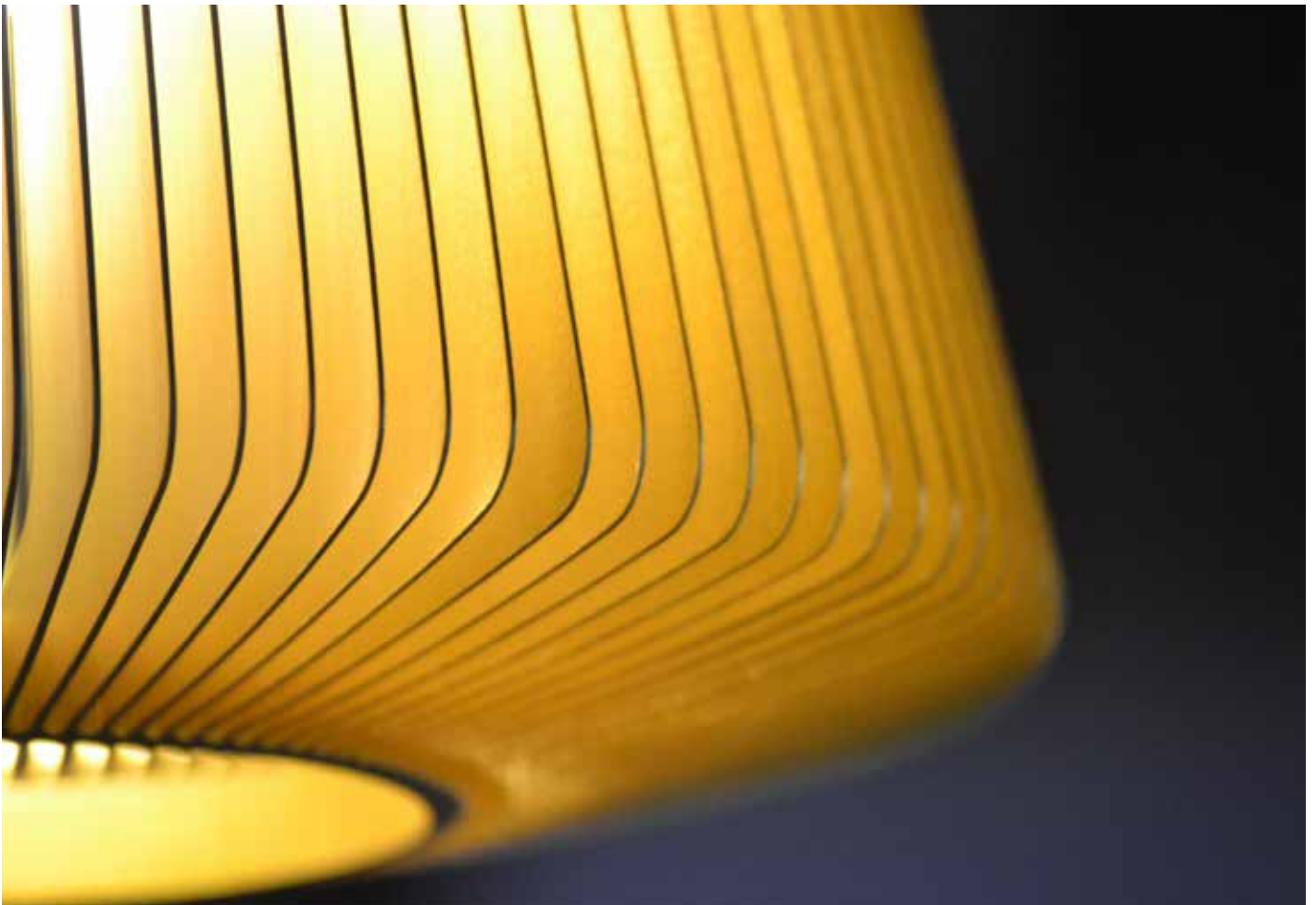

### Bramah Wall Small

Pale Gold  
 UK/EU: BMW-14043-SXXXD15  
 US: BMW-14875-SXXXD15

Copper  
 UK/EU: BMW-14043-SXXXD65  
 US: BMW-14875-SXXXD65

Grey  
 UK/EU: BMW-14043-SXXXK55  
 US: BMW-14875-SXXXK55

**Lightsource**  
 Integrated LED Source, Sharp Chip, chip life 30,000 hours, 2700K, 6x x 2.5W LED, 250lm, CRI (Ra) 93, Beam Angle 120  
 EU dimmable via leading/ trailing-edge+TRIAC dimmer,  
 US Dimmable via 0-10v + TRIAC dimmer

**Other**  
 Driver must be housed inside wall cavity or Junction Box, see spec sheet for dimensions.

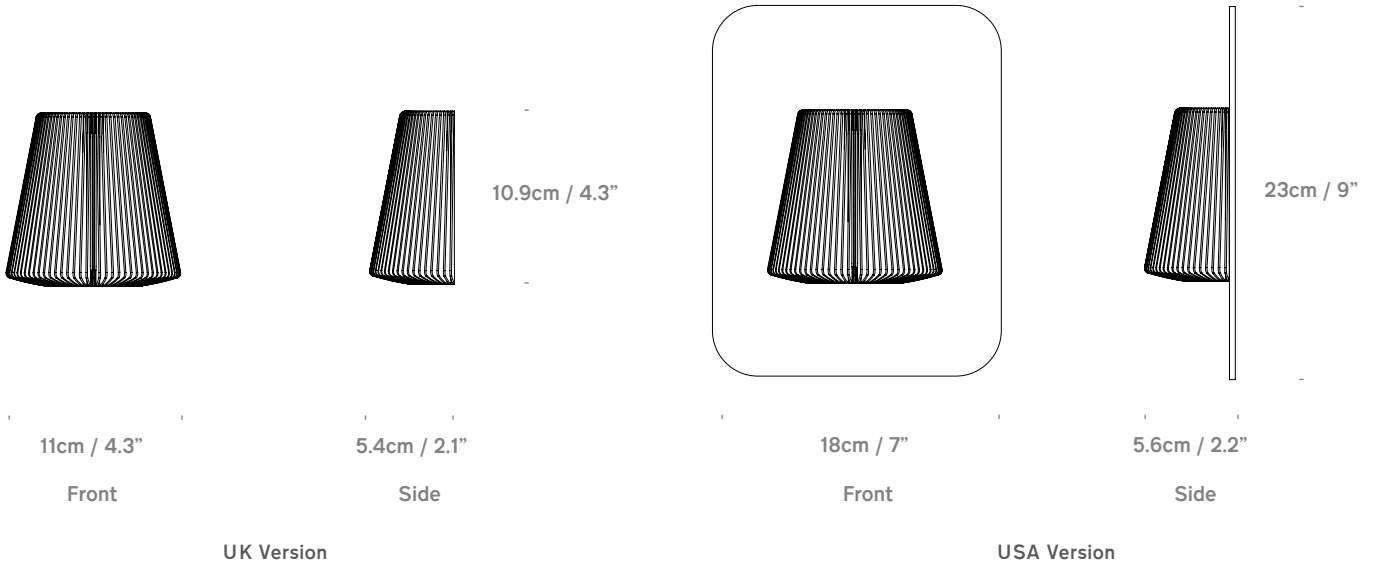

### Bramah Wall Large

Pale Gold  
 UK/EU: BMW-14032-SXXXD15  
 US: BMW-14874-SXXXD15

Copper  
 UK/EU: BMW-14032-SXXXD65  
 US: BMW-14874-SXXXD65

Grey  
 UK/EU: BMW-14032-SXXXK55  
 US: BMW-14874-SXXXK55

**Lightsource**  
 UK/EU: G9 Max 5W LED USA: G9 Max 5W LED

**Recommended Bulb**  
 Any G9 LED bulb up to 180 - 500 Lumen output,  
 dimmable. Temperature 2200 - 2800 Kelvin

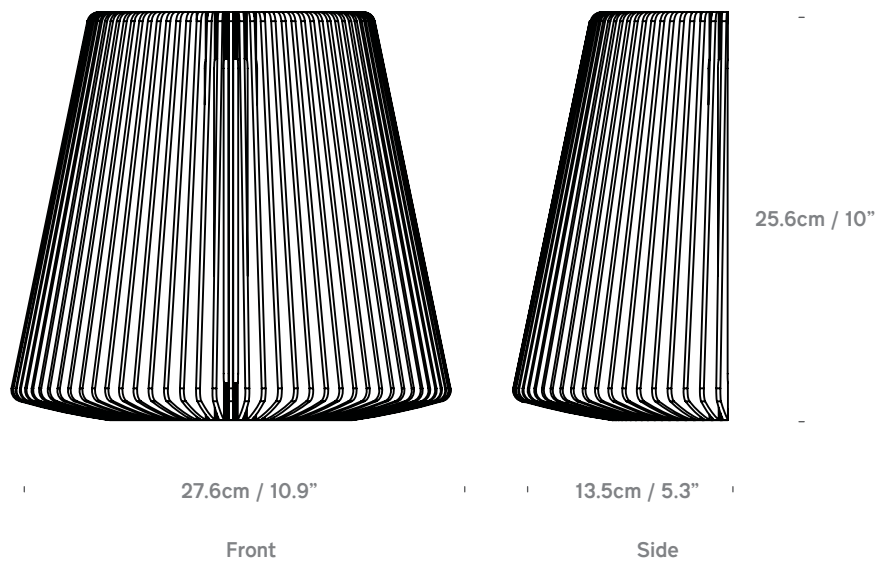

Material Aluminium  
 Finish Anodised  
 Colour Copper/ Pale Gold/ Grey

# Bramah Bedside

By Michael Young for EOQ



Bramah Bedside at Glow Spa Hong Kong

Pale Gold  
 UK/EU: BMB-14003-SXXXD15  
 US: BMB-14878-SXXXD15

Copper  
 UK/EU: BMB-14003-SXXXD65  
 US: BMB-14878-SXXXD65

Grey  
 UK/EU: BMB-14003-SXXXK55  
 US: BMB-14878-SXXXK55

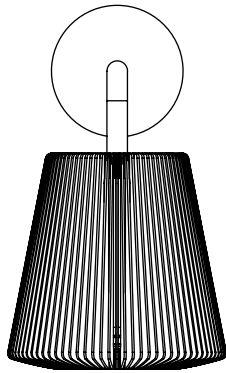

11cm / 4.3"

Front

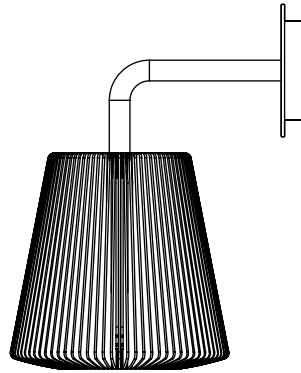

17.3cm / 6.8"

Side

20.1cm / 7.9"

UK Version

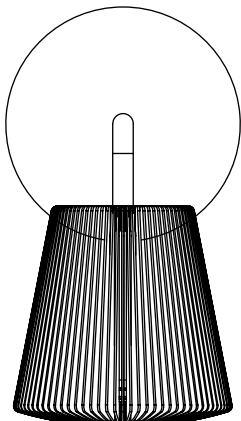

15cm / 5.9"

Front

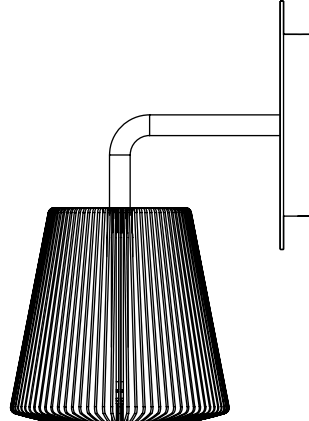

17.3cm / 6.8"

Side

23.6cm / 9.3"

USA Version

Material  
 Finish  
 Colour  
 Lightsource  
 Recommended Bulb

Aluminium  
 Anodised  
 Copper/ Pale Gold/ Grey  
 G9 UK/EU: Max 5W LED USA: Max 5W LED  
 Any G9 LED bulb up to 180 - 500 Lumen output, dimmable. Temperature 2200 - 2800 Kelvin

# Bramah Floor

By Michael Young for EOQ



Bramah Floor at GREAT Festival, Hong Kong



Bramah Floor at GREAT Festival, Hong Kong

Pale Gold  
 UK/EU: BMF-14010-SXXXD15  
 US: BMF-14880-SXXXD15

Copper  
 UK/EU: BMF-14010-SXXXD65  
 US: BMF-14880-SXXXD65

Grey  
 UK/EU: BMF-14010-SXXXK55  
 US: BMF-14880-SXXXK55

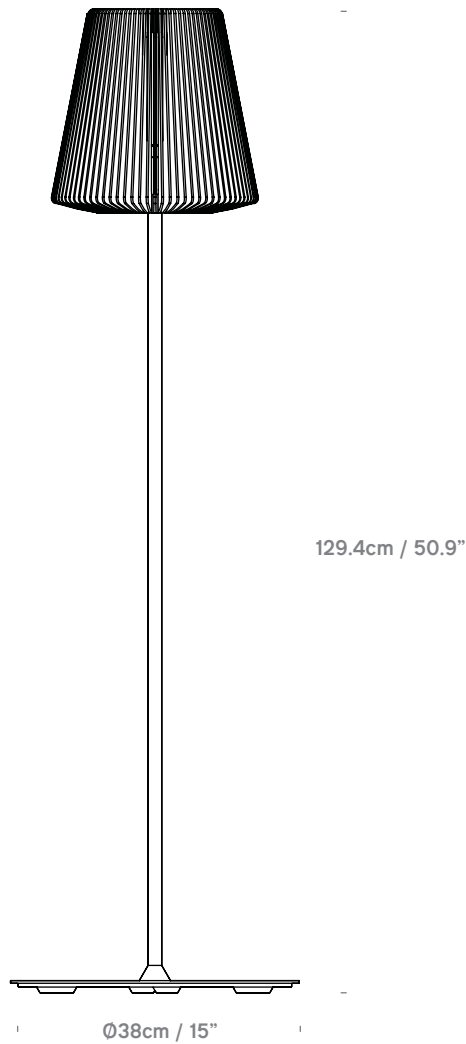

Material

Aluminium

Finish

Anodised

Colour

Copper/ Pale Gold/ Grey

Lightsource

UK/EU: G9 Max 5W LED USA: G9 Max 5W LED

Recommended Bulb

Filament or Pearl LED Globe Bulbs with 300 – 500 Lumen output and 2800 Kelvin

Cable

Black Cable. 38cm to switch, 150cm to plug

Switch

Inline foot



Joseph Pendants at TwoRuba Bar, Hilton Tower Bridge, London



Joseph Pendants Small in Private Apartment Reception



# Joseph

By Michael Young for EOQ



The soft Asian silhouette of the Joseph collection belies the reassuring strength of an object crafted from a solid block of aluminium. Each piece is extruded into shape, softened with CNC cutting before being milled on a lathe to open up the core and allow the light to diffuse through the fins.



Joseph Pendants Small in Coffee Shop



Joseph at Private Residence, London UK  
Photographer Ian Duncan

## Joseph Pendant Small

Pale Gold  
 UK/EU: JPP-14059-SXXXD15  
 US: JPP-14883-SXXXD15

Copper  
 UK/EU: JPP-14059-SXXXD65  
 US: JPP-14883-SXXXD65

Grey  
 UK/EU: JPP-14059-SXXXK55  
 US: JPP-1883-SXXXK55

Lightsource  
 G9 UK/EU: Max 5W LED USA: Max 5W LED

Recommended Bulb  
 Any G9 LED bulb up to 180 - 500 Lumen output,  
 dimmable. Temperature 2200 - 2800 Kelvin

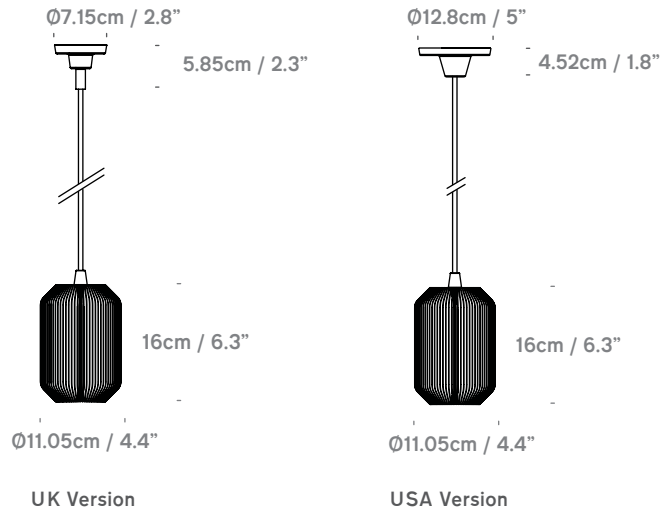

## Joseph Pendant Large

Pale Gold  
 UK/EU: JPP-14054-SXXXD15  
 US: JPP-14882-SXXXD15

Copper  
 UK/EU: JPP-14054-SXXXD65  
 US: JPP-14882-SXXXD65

Grey  
 UK/EU: JPP-14054-SXXXK55  
 US: JPP-14882-SXXXK55

Lightsource  
 UK/EU: E27 Max 15W LED USA: E26 Max 15W LED

Recommended Bulb  
 Filament or Pearl LED Globe bulbs  
 with 300 - 500 Lumen output, 2800 Kelvin

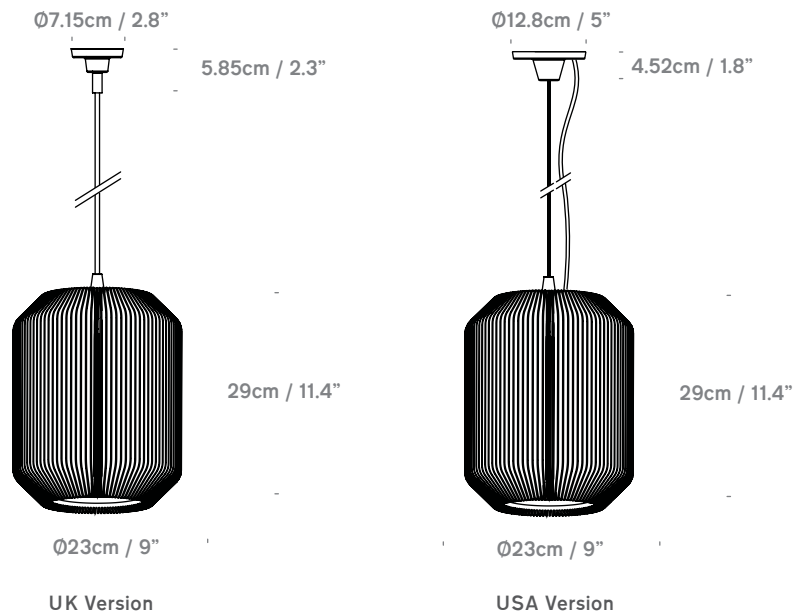

Material	Aluminium
Finish	Anodised
Colour	Copper/ Pale Gold/ Grey
Ceiling Rose	Same colour as shade
Cable	4m / Black braided

# Joseph Table

By Michael Young for EOQ

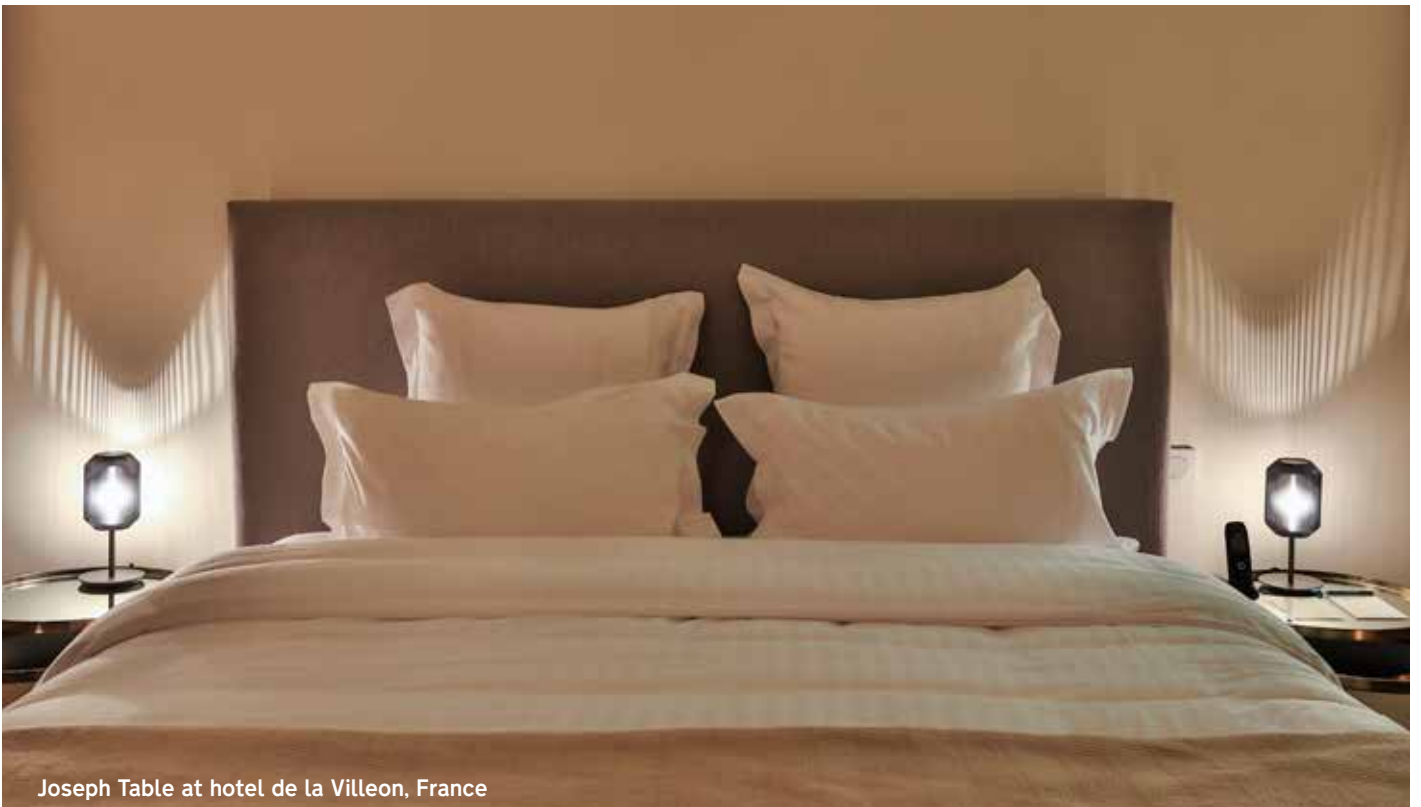

Joseph Table at hotel de la Villeon, France

Pale Gold  
UK/EU: JPT-14071-SXXXD15  
US: JPT-14887-SXXXD15

Copper  
UK/EU: JPT-14071-SXXXD65  
US: JPT-14887-SXXXD65

Grey  
UK/EU: JPT-14071-SXXXK55  
US: JPT-14887-SXXXK55

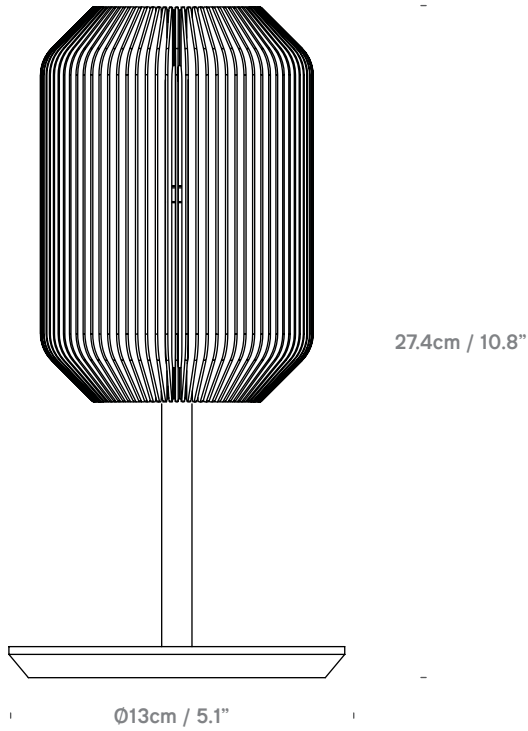

---

Material	Aluminium
Finish	Anodised
Colour	Copper/ Pale Gold/ Grey
Lightsource	G9 UK/EU: Max 5W LED USA: Max 5W LED
Recommended Bulb	Any G9 LED bulb up to 180 - 500 Lumen output, dimmable. Temperature 2200 - 2800 Kelvin
Cable	Black braided. 28.5cm to switch, 150.5cm to plug.
Switch	Inline rocker

# Joseph Wall

By Michael Young for EOQ



Joseph Wall in Wan Chai, HK

### Joseph Wall Small

Pale Gold  
 UK/EU: JPW-14062-SXXXD15  
 US: JPW-14877-SXXXD15

Copper  
 UK/EU: JPW-14062-SXXXD65  
 US: JPW-14877-SXXXD65

Grey  
 UK/EU: JPW-14062-SXXXK55  
 US: JPW-14877-SXXXK55

**Lightsource**  
 Integrated LED Source, Sharp Chip, chip life 30,000 hours, 2700K, 6x x 2.5W LED, 250lm, CRI (Ra) 93, Beam Angle 120  
 EU dimmable via leading/ trailing-edge+TRIAC dimmer,  
 US Dimmable via 0-10v + TRIAC dimmer

**Other**  
 Driver must be housed inside wall cavity or in Junction Box. See spec sheet for sizing

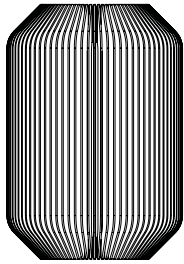

11.05cm / 4.4"

Front

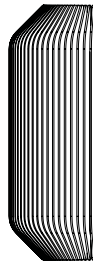

16cm / 6.3"

5.4cm / 2.1"

Side

UK Version

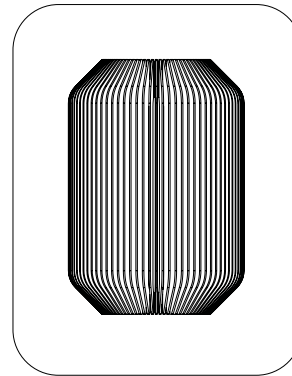

18cm / 7"

Front

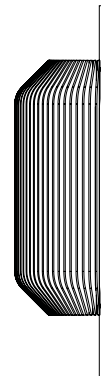

23cm / 9"

5.6cm / 2.2"

Side

USA Version

### Joseph Wall Large

Pale Gold  
 UK/EU: JPW-14053-SXXXD15  
 US: JPW-14876-SXXXD15

Copper  
 UK/EU: JPW-14053-SXXXD65  
 US: JPW-14876-SXXXD65

Grey  
 UK/EU: JPW-14053-SXXXK55  
 US: JPW-14876-SXXXK55

**Lightsource**  
 UK/EU: G9 Max 5W LED USA: G9 Max 5W LED

**Recommended Bulb**  
 Any G9 LED bulb up to 180 - 500 Lumen output, dimmable. Temperature 2200 - 2800 Kelvin

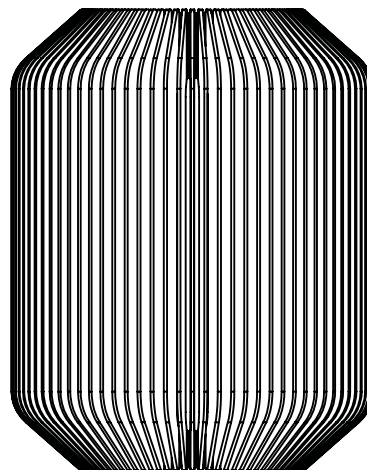

23cm / 9"

Front

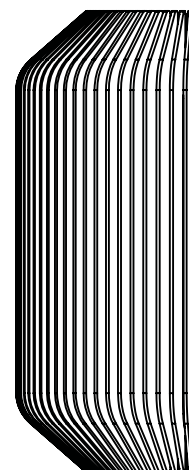

29cm / 11.4"

11.2cm / 4.4"

Side

Material	Aluminium
Finish	Anodised
Colour	Copper/ Pale Gold/ Grey

# Joseph Bedside

By Michael Young for EOQ





Pale Gold  
 UK/EU: JPB-14173-SXXXD15  
 US: JPB-14879-SXXXD15

Copper  
 UK/EU: JPB-14173-SXXXD65  
 US: JPB-14879-SXXXD65

Grey  
 UK/EU: JPB-14173-SXXXK55  
 US: JPB-14879-SXXXK55

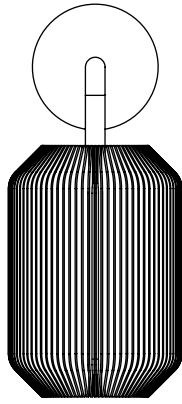

11cm / 4.3"

Front

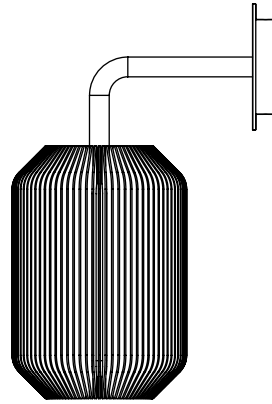

17.3cm / 6.8"

Side

25cm / 9.8"

UK Version

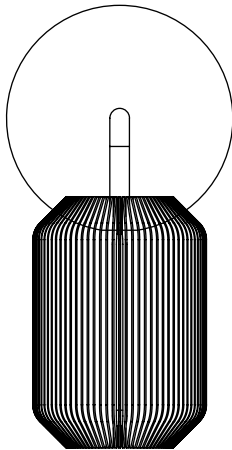

15cm / 5.9"

Front

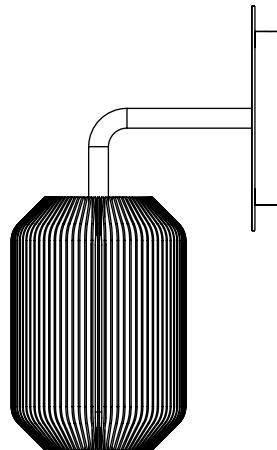

17.3cm / 6.8"

Side

28.5cm / 11.2"

USA Version

Material	Aluminium
Finish	Anodised
Colour	Copper/ Pale Gold/ Grey
Lightsources	G9 UK/EU: Max 25W USA: Max 25W
Recommended Bulb	Any G9 LED bulb up to 180 - 500 Lumen output, dimmable. Temperature 2200 - 2800 Kelvin
Ceiling Rose	Same colour as shade
Cable	4m / Black braided

# Joseph Floor

By Michael Young for EOQ



Joseph Floor at GREAT Festival, Hong Kong



Joseph Floor at GREAT Festival, Hong Kong

Pale Gold  
 UK/EU: JPF-13925-SXXXD15  
 US: JPF-14881-SXXXD15

Copper  
 UK/EU: JPF-13925-SXXXD65  
 US: JPF-14881-SXXXD65

Grey  
 UK/EU: JPF-13925-SXXXK55  
 US: JPF-14881-SXXXK55

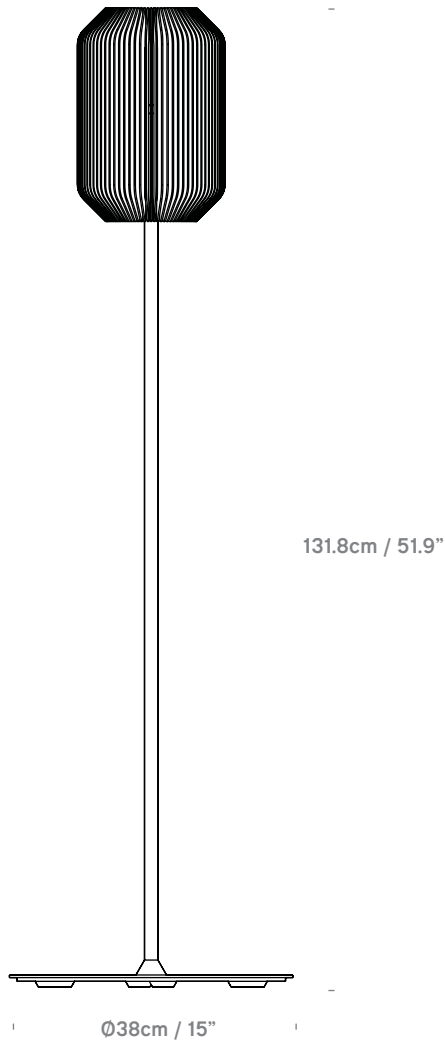

Material

Aluminium

Finish

Anodised

Colour

Copper/ Pale Gold/ Grey

Lightsource

UK/EU: E27 Max 15W LED USA: E26 Max 15W LED

Recommended Bulb

Filament or Pearl LED Globe Bulbs with 300 – 500 Lumen output and 2800 Kelvin

Ceiling Rose

Black Cable. 38cm to switch, 150cm to plug.

Cable

Inline foot



Dub Medium Pendant in Private Apartment Lobby

# Dub

By Michael Young for EOQ



Starting with the same raw extrusion they have sculpted much softer forms by removing a lot more aluminium material. This allowed them to encase the resultant space in beautiful hand blown glass from the Czech Republic. The Glass shades are packed separately enabling you to create your own colour combinations of glass and aluminium.



Dub at La Mourra, Val D'Isere, France

## Dub Pendant Small

Glass - Green  
520-14942-XXXXG40

Glass - Smoke  
520-14942-XXXXK30

Glass - Amber  
520-14942-XXXXO40

Aluminum - Pale Gold  
520-14808-SXXXD15

Aluminum - Silver  
520-14808-SXXXS50

### Lightsource

G9 UK/EU: Max 5W LED USA: Max 5W LED

### Recommended Bulb

Any G9 LED bulb up to 180 – 500 Lumen output, dimmable. Temperature 2200 – 2800 Kelvin

UK/EU Ø7.15cm / 2.8"  
USA Ø12.8cm / 5"

UK/EU 5.85cm / 2.3"  
USA 4.52cm / 1.8"

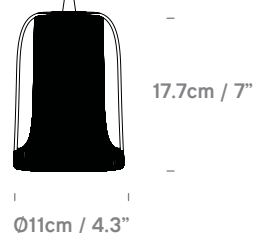

## Dub Pendant Medium

Glass - Green  
520-14941-XXXXG40

Glass - Smoke  
520-14941-XXXXK30

Glass - Amber  
520-14941-XXXXO40

Aluminum - Pale Gold  
520-14807-SXXXD15

Aluminum - Silver  
520-14807-SXXXS50

### Lightsource

G9 UK/EU: Max 5W LED USA: Max 5W LED

### Recommended Bulb

Any G9 LED bulb up to 180 – 500 Lumen output, dimmable. Temperature 2200 – 2800 Kelvin

UK/EU Ø7.15cm / 2.8"  
USA Ø12.8cm / 5"

UK/EU 5.85cm / 2.3"  
USA 4.52cm / 1.8"

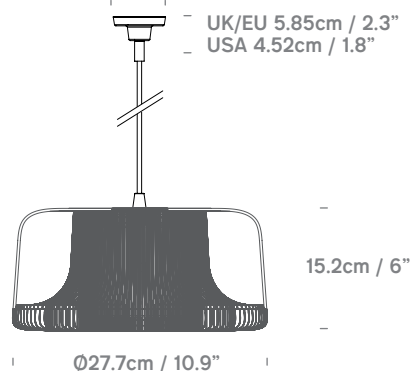

## Dub Pendant Large

Glass - Green  
520-14940-XXXXG40

Glass - Smoke  
520-14940-XXXXK30

Glass - Amber  
520-14940-XXXXO40

Aluminum - Pale Gold  
520-14806-SXXXD15

Aluminum - Silver  
520-14806-SXXXS50

### Lightsource

UK/EU: E27 Max 15W LED USA: E26 Max 15W LED

### Recommended Bulb

Filament or Pearl LED Globe bulbs with 300 – 500 Lumen output, 2800 Kelvin

Ø12.8cm / 5"

4.52cm / 1.8"

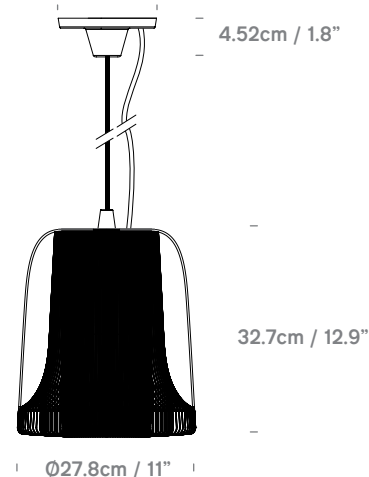

### Material

Aluminium and Glass

### Finish

Anodised

### Glass

Green/ Smoked/ Amber

### Aluminum

Pale Gold/ Grey/ Copper

### Ceiling Rose

Same colour as shade

### Cable

4m / Black braided (Large has external tensile wire)

# Radiate

By Innermost

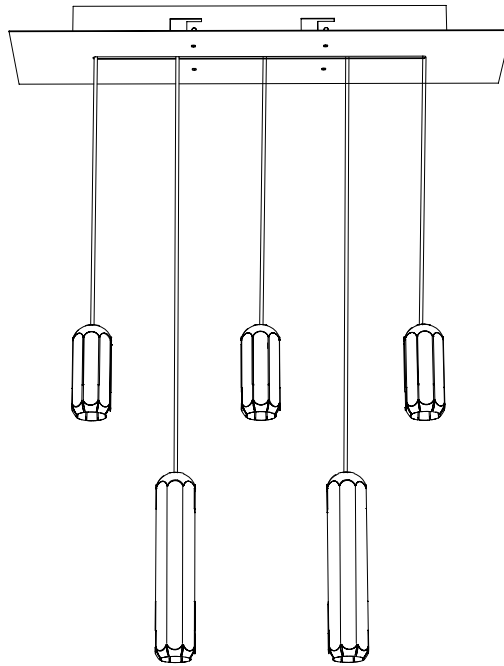

Radiate is a range of ceiling roses that allow a variety of configurations for pendant light clusters.

Radiate 30 suits smaller circular configurations, with Radiate 60 available for multiple pendants or clusters of larger pendants. Radiate Linear can be used for a consecutive line of fittings – perfect for over a countertop or rectangular table.

Using Radiate can enable an easy installation of up to 8 pendant lights with only 1 fixture and connection. It also provides a neat aesthetic, eliminating the needs for multiple ceiling roses.

Radiate is compatible with all Innermost pendant lights and can be used with other fixtures.



**Radiate Circular 30**

ZR03CR30W

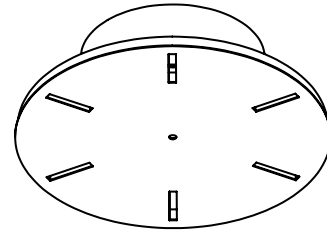
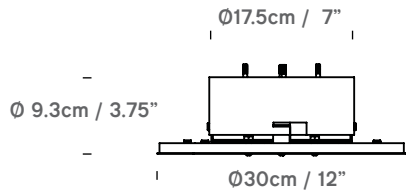

**Radiate Circular 60**

ZR03CR60W

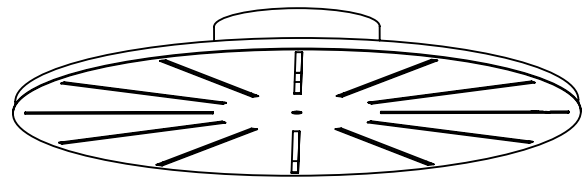
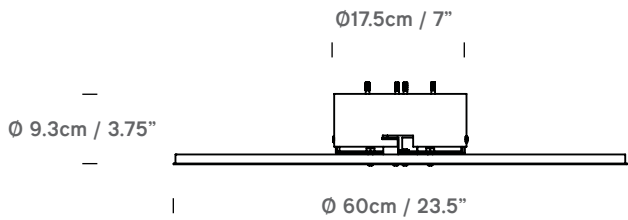

**Radiate Linear 60**

ZR03LR60W

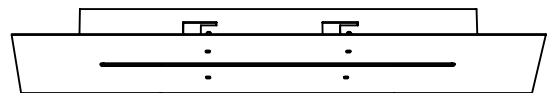
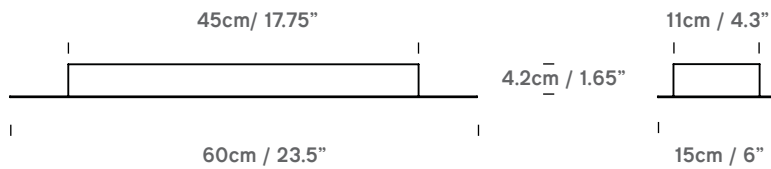

Material	Steel
Colour	White
Maximum load that can be suspended	10kg

# Designers



## Ben McCarthy

Born and raised in Sydney, Ben graduated in Industrial Design from UNSW in 2003. A year later, the British Council facilitated his move to the UK where he worked in the Tom Dixon studio. In 2007 he relocated to Hong Kong where he is still based, working in the office of Michael Young. Over the years Ben's designs have attracted several awards and grants; the Australian Council, British Council, a solo show at the Object Gallery in Sydney, and exhibitions in Tokyo, Milan, Hong Kong, London, and more.



## Jette Scheib

Jette Scheib studied industrial design at the University of the Arts, Berlin (UdK), and has worked since 2005 as an independent product designer specializing in homeaccessories. Her work can be plain and pure, or narrative and playful, but often with a little twist that adds a new context or dimension to a functional object. Inspiration is everywhere: whether it is art, music, people and their stories, habits, clichés or simply life itself that feeds.



## James Bartlett

James Bartlett studied at Manchester Metropolitan and joined Innermost's London studio in 2008, later taking the position of Design Manager. His design is characterised by an interest in material and process and he enjoys being in the workshop to participate in every stage of production. Portland is a great example of this: what began as a project to experiment with a cast concrete process developed into the unique product available in both concrete and plaster. Deliberately coarse and bubbly concrete holding a strong contrast against flawlessly smooth plaster surface.



## Michael Young for EOQ

The initial EOQ collections were made under the design direction of Michael Young, one of the generation's most influential British designers.

Rooted in a spirit of enquiry and industrial adventure, they use classic design principles with a new and constantly evolving vocabulary, delivering perfectly engineered pieces with sublime, sleek finishes. From extruded aluminium to hand blown glass, each design is crafted with precision engineering; quality that is evident when admired up-close.



## Stone Designs

Designers Cutu Mazuelos and Eva Prego established Stone Design Concepts Inc. in 1995 to tell a story from their perspectives and without censorship. Having never worked for anyone else, lessons were learned and skills were mastered through personal hardship and sacrifice. Starting with interior designs, stands and displays, they worked with such names as Lexus, Telepizza, Havaianas, and Coca Cola. They also designed furniture for brands such as Muji Japan. Stone Designs is the constant search for new languages, a passion and reason for living.



## Steve Jones

After studying Industrial Design at Newcastle Polytechnic, Steve Jones started his career in design consultancy. His highly diverse design experience included ladies shoes, books, toys and even naval architecture. Later he worked extensively in the furniture industry, before moving into lighting and forming Innermost with Russell Cameron in 1999.

His varied interest in design is reflected in the diverse aesthetic of the Innermost collections. As well as his own designs, Jones has brought in names like Michael Young, Jarrod Lim, Corinna Warm, Stone Designs and Shin Azumi, helping to shape a range that has breadth as well as depth.



## Tina Leung

Originally from Hong Kong, Tina Leung studied at Central Saint Martins in London, England, before returning to her roots to work for Innermost. Her portfolio includes working for Shanghai Tang designing accessories and Alan Chan Design in Hong Kong. Tina's work is influenced strongly by modern Asian animation and illustration styles and in her own words she 'plays with materials to create opportunities'. Tina joined Innermost in 2004 and her first products, including 'Kapow', were launched in February 2005.



## Winnie Lui

Winnie Lui graduated from Central Saint Martins in Fashion Communication and Promotion. At once a fashion stylist, photographer and custom jewellery designer. Lui has been a stylist for singer/actress Gigi Leung, worked for photographer Wing Shya in Hong Kong, while attaining the knowledge of silversmithing from London-based jewellery designer Lara Bohinc. Inspired by her surroundings, obsessed with both new and vintage toys, she is attracted to small details and everyday objects that are beautiful but seem unimportant. Lui's exclusive collaboration with Innermost has produced exciting creations, where fashion meets product design.



## Tom Kirk

Born in Manchester in 1972, Tom Kirk studied at Middlesex University and Camberwell School of Art, graduating with a first class honours degree in Silversmithing and Metalwork in 1994. In 1997, Tom was awarded a Crafts Council setting up grant and formally established his studio, designing and producing one-off and batch produced lights. Several of these early designs are still in production today. Today, Kirk's designs reflect over a decade's experience in manufacturing processes; working with a diverse range of techniques and materials.

# Agents & Distributors

## UK/ Europe Office & Showroom

www.innermost.net  
+44 (0)20 7620 1808  
info@innermost.net

## Asia Sales Office

www.innermost.net  
+852 2857 5289  
info@innermost.net

### Australia

ECC  
ecc.aus@innermost.net

### Austria

TOTAL SOLUTION  
austria@innermost.net

### Belgium

BELUCE  
beluce@innermost.net

### Bosnia & Herzegovina

FABIO ZAMUNER  
zamest@innermost.net

### Bulgaria

ASSEN KARAGEORGIEV  
bulgaria@innermost.net

### Canada

LIGHTFORM CANADA  
lightform@innermost.net

### China

SHANGHAI GLOWELL TRADING CO., LTD  
thisisxiaofang@qq.com

### Croatia and Slovenia

FABIO ZAMUNER  
zamest@innermost.net

### Cyprus

ILIAS ELIEZER, LAZAROS ELIEZER  
greece-cyprus@innermost.net

### Czech Republic

MARIO CASAGRANDE  
casagrande@innermost.net

### Denmark

STEEN ANDERSON  
denmark@innermost.net

### Estonia

MARIO CASAGRANDE  
casagrande@innermost.net

### Finland

DECOLIGHT OY  
decolight@innermost.net

### France

paris@innermost.net  
Areas covered: Région Ile De France

### ALAIN CLEMENT

clement@innermost.net  
Areas covered: Auvergne-Rhône-Alpes,  
Lozère

### CÉCILE MONTEIL

monteil@innermost.net  
Areas covered: Occitanie (except :  
Lozère, Gard, Hérault), Corrèze, Creuse,  
Dordogne, Gironde, Haute-Vienne, Landes,  
Lot-et-Garonne, Pyrénées-Atlantiques

### GAUTHIER BRUINEN

bruinen@innermost.net  
Areas covered: Haut de France, Ardènes

### MARTIAL FROMY

fromelec@innermost.net  
Areas covered: Vienne, Charente, Char-  
ente Maritime, Dex Sèvres, Vienne, Indre  
et Loire, Pays de la Loire, Bretagne, Orne,  
Calvados, Manche

### Germany

DIRK SCHÄUBLE  
schaeuble@innermost.net  
Areas covered: Germany compl. 2 /  
31-32-33

HERMANN SCHEPERS FUNIO VERTRIEB  
schepers@innermost.net  
Areas covered: Germany compl. 4 /  
50-51-52-59 / 30-37-38

HUBERTUS LGGES  
igges@innermost.net  
Areas covered: Germany compl. 8/  
compl. 9

STEFFEN KNOPP  
knopp@innermost.net  
Areas covered: Germany 34-35-36 /  
53-54-55-56-57/ compl. 6 / 75-76-77-79

### Greece

ILIAS ELIEZER, LAZAROS ELIEZER  
greece-cyprus@innermost.net

### Hungary

MARIO CASAGRANDE  
casagrande@innermost.net

**Italy**

ELIO SCHINOCCA  
italy@innermost.net  
Area covered: Sicilia

FABIO ZAMUNER  
zamest@innermost.net  
Area covered: Triveneto

FILIPPO VEGEZZI  
italy@innermost.net  
Areas covered: Lombardia

LUIGI BRIA  
italy@innermost.net  
Areas covered: Calabria

MARCO CIAPPELLI  
italy@innermost.net  
Area covered: Toscana, Umbria

MAURO ETTARI  
italy@innermost.net  
Area covered: Campania

PAOLO BARILE  
barile@innermost.net  
Area covered: Roma, Lazio

SP RAPPRESENTANZE  
italy@innermost.net  
Area covered: Puglia, Basilicata, Abruzzo

VM RAPPRESENTANZE  
italy@innermost.net  
Area covered: Emilia-Romagna

**Latvia**

MARIO CASAGRANDE  
casagrande@innermost.net

**Lithuania**

MARIO CASAGRANDE  
casagrande@innermost.net

**Macedonia**

FABIO ZAMUNER  
zamest@innermost.net

**Mexico**

INTERIORES 0503  
interiores@innermost.net

**Montenegro**

FABIO ZAMUNER  
zamest@innermost.net

**New Zealand**

ECC LIMITED  
ecc.nz@innermost.net

**Norway**

ANJA ISACHSEN  
norway@innermost.net

**Poland**

LIBRA SZYMON SNIEGOCKI  
poland@innermost.net  
Area covered: Szymon Sniegocki

**Portugal**

NORMO  
portugal@innermost.net

**Romania**

SORIN TOADER  
romania@innermost.net

**Russia / Belarus / Georgia / Armenia**

LITEHOUSE AGENCY  
russia@innermost.net

**Serbia**

FABIO ZAMUNER  
zamest@innermost.net

**Singapore**

LIGHT + FORM CONCEPTS  
singapore@innermost.net

**Slovakia**

MARIO CASAGRANDE  
casagrande@innermost.net

**Spain**

RE-SOLT  
spain@innermost.net  
Areas covered: Comunidad, Valenciana, Murcia

JAVIER GARCIA  
spain@innermost.net  
Area covered: Madrid

LUIS LOPEZ  
spain@innermost.net  
Areas covered: Aragon, Pais, Vasco, Rioja, Navarra

MIQUEL BONAGA  
spain@innermost.net  
Areas covered: Catalonia, Balears, Andorra

YOLANDA VIDAL  
spain@innermost.net  
Areas covered: Castilla-Leon, Cantabria, Asturias, Galicia

**Sweden**

CIRCLE  
circle@innermost.net

**Switzerland**

THOMAS FLAVELL  
switzerland@innermost.net

**Taiwan**

FASHION LIGHTING GROUP  
flg@innermost.net

**The Netherlands**

ENZO REITANO  
netherlands@innermost.net

**Ukraine**

ANNA VINIKOVA  
ukraine@innermost.net

**USA**

IM DESIGN CONCEPTS  
imdc@innermost.net

**Innermost  
&  
the industry**





## Manufacture

We are passionate about each design and every level of detail that goes into its manifestation. We have always placed production where the best skills can be found for the material or process. We travel across the globe sourcing the best quality materials and the most suitable producers for each product and every component. Whether we are prototyping in Hong Kong, using hand-blown glass by artisans in the Czech Republic, or doing bespoke engineering at our factory in the UK, we stay close to the manufacturing development at every level.



## Bespoke design & OEM

After 19 years, we continue to produce many of our lights and lampshades in the UK, at our facility in Telford, with ownership over everything from production, assembly, testing, packaging, and warehousing. This in-house management of the entire process allows us to guarantee the highest standard of quality, as well as giving us full flexibility when it comes to bespoke product.

We often use our expertise to develop and manufacture products for other high-end design houses in an OEM capacity. From licensing and manufacturing existing designs, to providing a full design consultancy, we offer a unique and tailored service and are able to produce in high volume and absolute one-offs. Please contact us if you are interested in hearing more about our design and production services.







**UK / Europe Office & Showroom**

2.02 - 2.04 Oxo Tower Wharf  
Bargehouse Street  
South Bank  
London  
United Kingdom  
SE1 9PH

**T: +44 (0)20 7620 1808**

**E: [info@innermost.net](mailto:info@innermost.net)**

**W: [innermost.net](http://innermost.net)**