



LIGHT IS DESIGN





# LA LUCE SECONDO PENTA

*Light according Penta*



[pentalightgroup.it](http://pentalightgroup.it)



[pentalight.com](http://pentalight.com)



[penta-arch.it](http://penta-arch.it)



[pcustomlight.it](http://pcustomlight.it)



[arredoluce.com](http://arredoluce.com)

Il design tra decorazione e contemporaneità di Penta Light, l'illuminazione tecnica di Penta Architectural, il made to measure di P Custom, le riedizioni dei maestri di Arredoluce. Dalla fusione di quattro realtà d'eccellenza del mondo dell'illuminazione è nato Penta Group: quattro brand, ciascuno con la propria autonomia, per quattro approcci progettuali accomunati dall'idea di trovare una sintesi tra funzionalità, tecnologia e bellezza.

The decorative yet contemporary design by Penta Light, the technical lighting by Penta Architectural, the made to measure by P Custom, the new editions of the Masters by Arredoluce. The fusion of these four outstanding companies in the lighting world gave birth to Penta Group: four brands, each with a strong characterization, four design approaches sharing the idea of finding a synthesis between functionality, technology and beauty.

**PENTA**

# GEOGRAFIA DELLA LUCE

*A light — geography*



Ogni lampada è il risultato dell'incontro tra la luce e lo spazio. Un binomio perfetto che le lampade Penta arricchiscono con la qualità di un design unico, espressione di un'eleganza sofisticata e di una bellezza senza tempo.

Luce, spazio e bellezza sono anche il fil rouge di questo racconto che inizia a Milano, storica capitale del design made in Italy, attraversa il Veneto delle ville palladiane e arriva a Venezia, città depositaria della tradizione decorativa italiana e della lavorazione del vetro.

Una narrazione che è anche un viaggio attraverso le nostre geografie: da Milano – insieme alla Brianza il luogo del saper fare e della storia di Penta – al Veneto, nuovo approdo di un Gruppo che ha fatto dell'illuminazione di qualità, in ogni ambito, la sua filosofia.

Each lamp is the result of the encounter between light and space. A perfect match that Penta lamps enrich with the quality of a unique design, expression of refined elegance and timeless beauty.

Light, space and beauty are as well the common thread in this tale that starts in Milan, historical capital of Italian design, crosses the Palladian Villas in Veneto and lands in Venice, beating heart of the Italian decorative tradition and the secrets of processing glass.

A tale which is also a journey through our geographies: from Milan – together with Brianza the place of know-how and of Penta history – straight to Venice, new landing port for a Group that has declared quality lighting its philosophy, in every way.

# INDEX

## A

ANGOLO .....	16
ACORN .....	24
APRILE .....	30

## B

BAG .....	36
-----------	----

## C

C'HI .....	40
CHINA .....	52
CLASH .....	62
CLIP .....	66

## E

ELISABETH .....	72
ENOKI .....	84

## F

FEEL .....	90
------------	----

## G

GLO .....	100
-----------	-----

## J

JACQUELINE .....	124
JEI JEI .....	134
JE SUIS .....	140

## K

KLINT .....	148
-------------	-----

## L

LAB .....	154
LIT .....	160
LULA .....	170

## M

MAMÌ .....	180
MOM .....	202

## N

NARCISO .....	226
---------------	-----

## P

POLAR .....	244
POP .....	250

## S

SPOON .....	256
STORM .....	272

## T

TAAAC .....	280
-------------	-----

## W

WONDER .....	286
WOODY .....	292

## *Our Heritage*

NEW CLASSIC .....	300
TIC & TOC .....	312
TOSCA .....	320
BRIDGET COLLECTION .....	326

## *Sospensioni in tessuto*

### *Fabric suspensions*

CILINDRO .....	332
CILINDRO ALTO .....	334
CILINDRI BASSI .....	336
CILINDRO DOPPIO .....	338
UP-DOWN .....	340
LUXURY .....	342
SLIDE .....	344
RETTANGOLARE .....	346
VANITY .....	348
CLUB HOUSE .....	350

# SOSPENSIONE / SUSPENSION

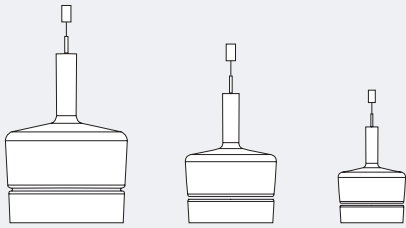

**ACORN.....24**

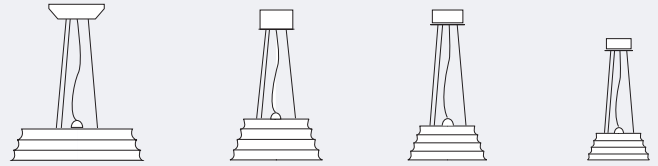

**C'HI.....40**

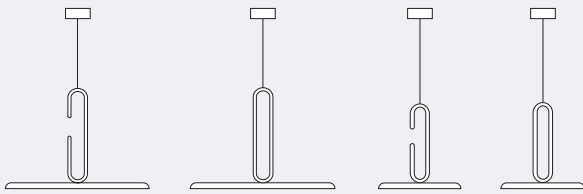

**CLIP.....66**

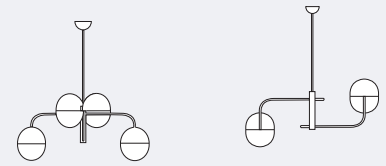

**ELISABETH.....72**

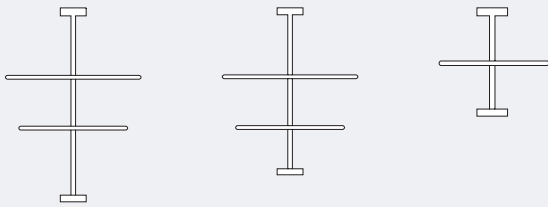

**FEEL.....90**

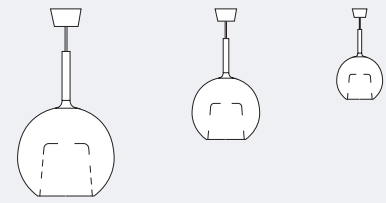

**GLO.....100**

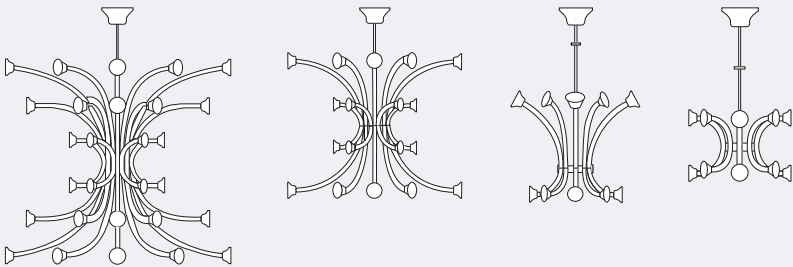

**JEI JEI.....134**

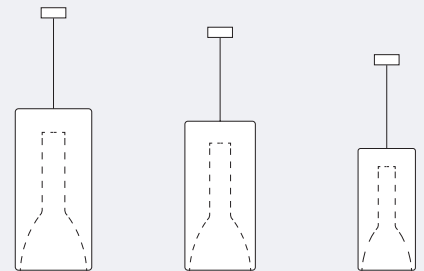

**LIT.....160**

# SOSPENSIONE / SUSPENSION

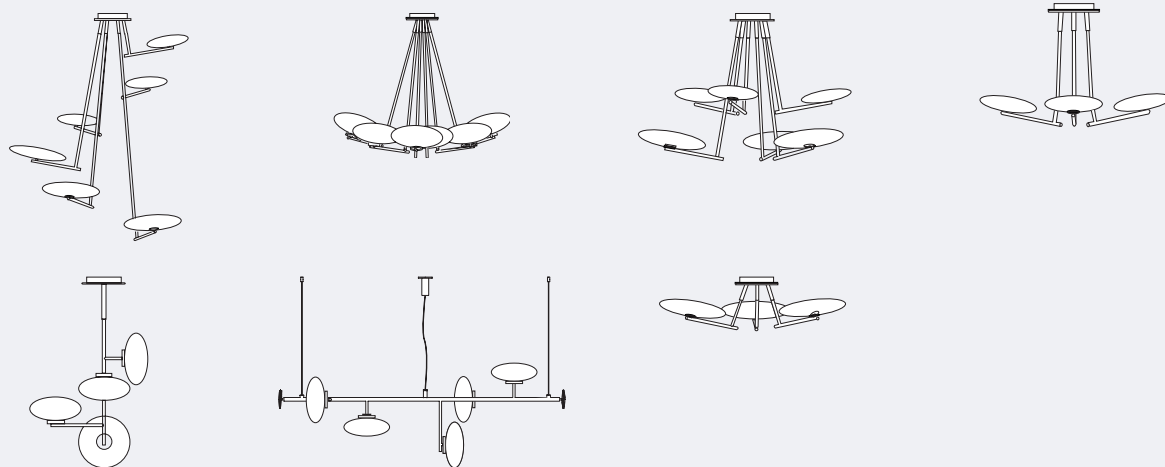

**MAMI**.....180

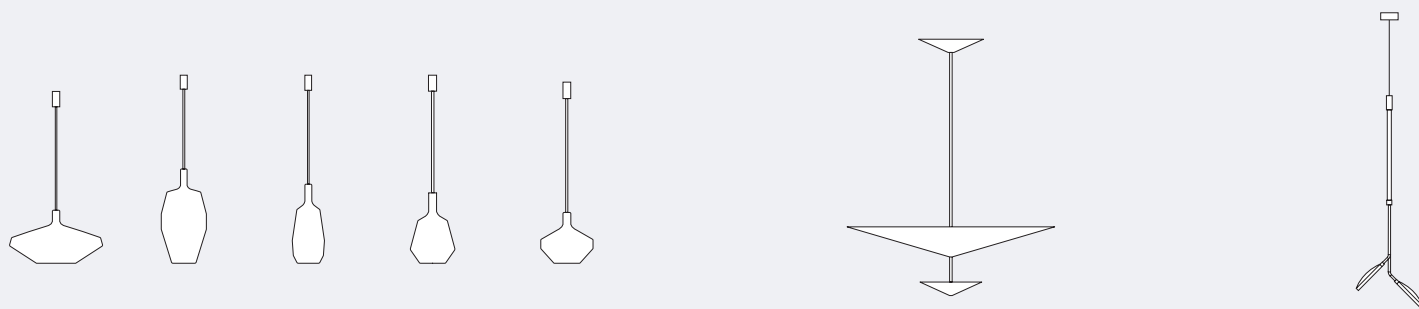

**MOM**.....202

**NARCISO**.....226

**SPOON**.....256

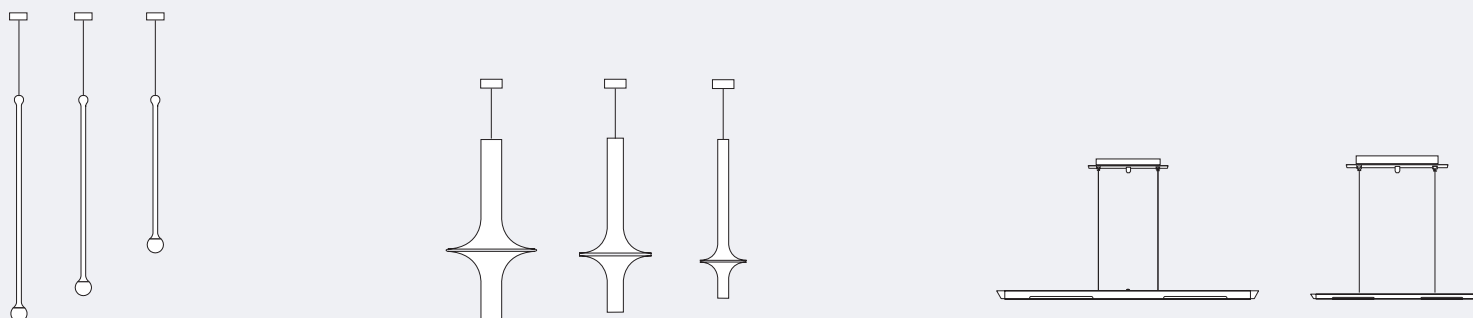

**STORM**.....272

**WONDER** ..... 286

**WOODY**.....292

# APPLIQUE / WALL

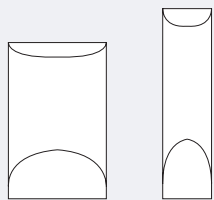

**APRILE ..... 30**



**C'HI..... 50**

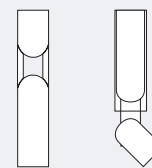

**CLASH ..... 62**

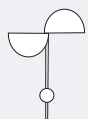

**ELISABETH ..... 80**



**ENOKI..... 84**

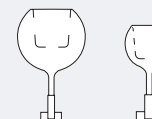

**GLO ..... 120**

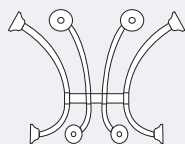

**JEI JEI ..... 138**

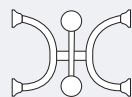

**MAMÌ..... 198**

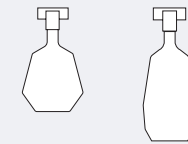

**MOM ..... 220**



**POP..... 250**

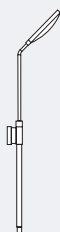

**SPOON..... 268**



**BRIDGET COLLECTION ..... 326**

# TAVOLO / TABLE

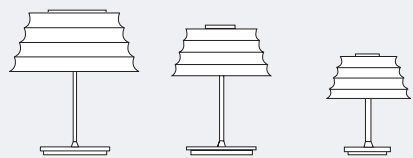

**C'HI.....46**

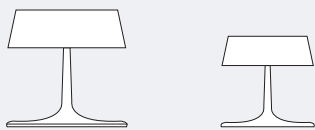

**CHINA.....52**

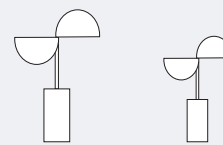

**ELISABETH .....74**

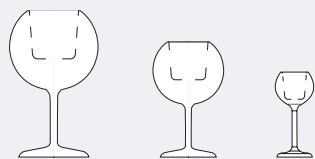

**GLO.....112**

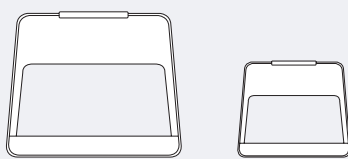

**JACQUELINE.....124**



**JE SUIS.....140**

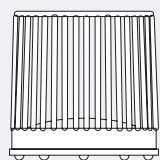

**KLINT .....148**

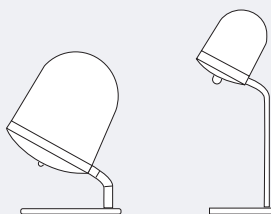

**LULA .....170**



**MAMÌ.....184**

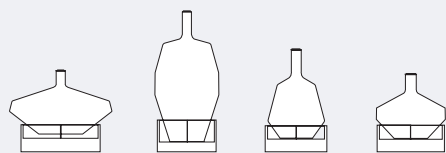

**MOM .....216**

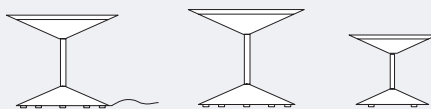

**NARCISO.....226**

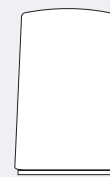

**POLAR .....247**





**SPOON..... 262**

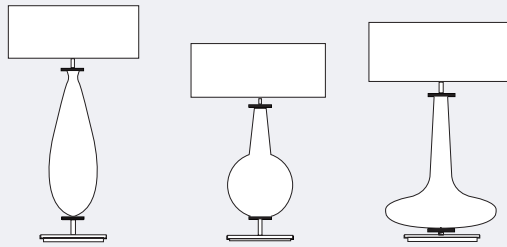

**NEW CLASSIC ..... 304**

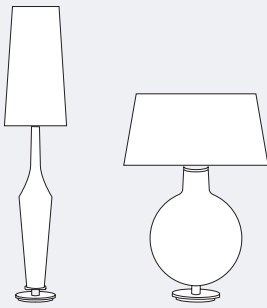

**TIC & TOC..... 312**

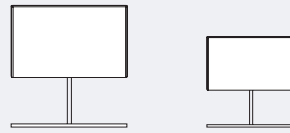

**TOSCA ..... 322**

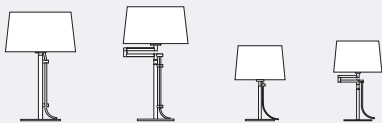

**BRIDGET COLLECTION..... 326**

# TERRA / FLOOR

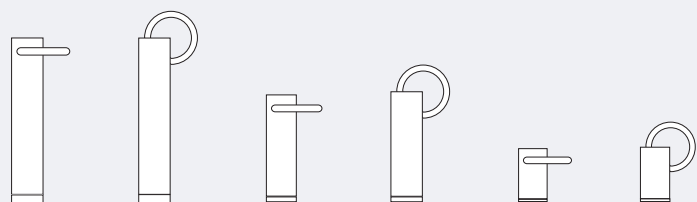

**ANGOLO** ..... 16

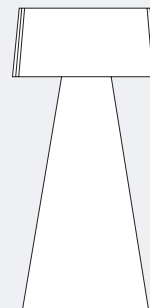

**BAG** ..... 36



**C'HI** ..... 48

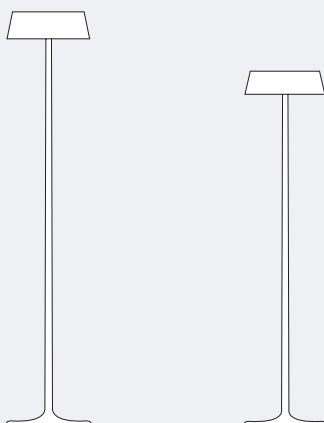

**CHINA** ..... 56



**GLO** ..... 116



**JE SUIS** ..... 144

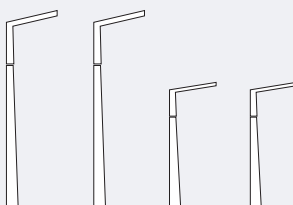

**LAB** ..... 154

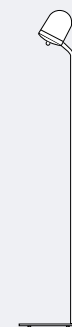

**LULA** ..... 176

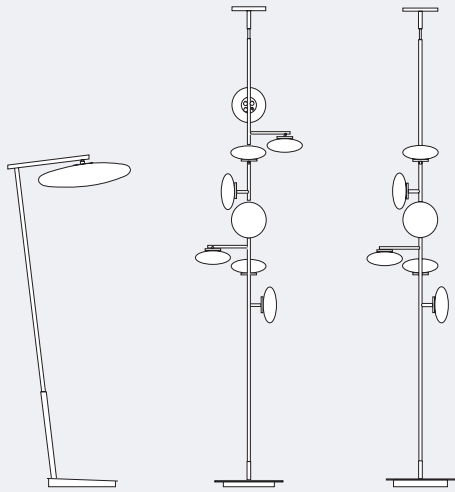

**MAMÌ..... 180**

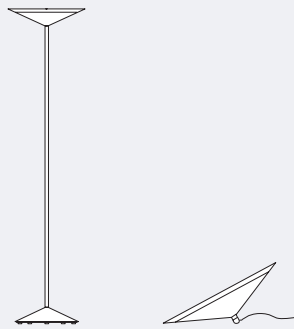

**NARCISO..... 237**



**POLAR..... 244**

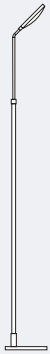

**SPOON..... 264**

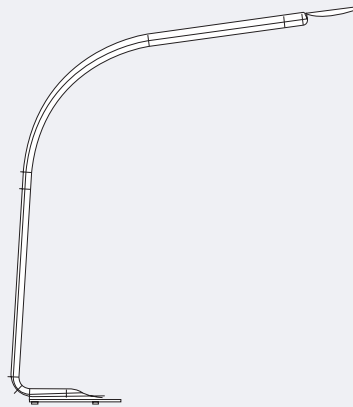

**TAAAC..... 280**

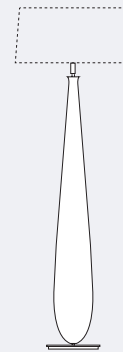

**NEW CLASSIC..... 300**



**TOSCA..... 320**

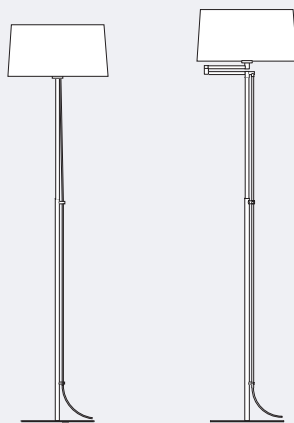

**BRIDGET COLLECTION..... 328**

# SOSPENSIONI, PLAFONIERE, APPLIQUES IN TESSUTO / FABRIC PENDANTS, CEILINGS AND APPLIQUES

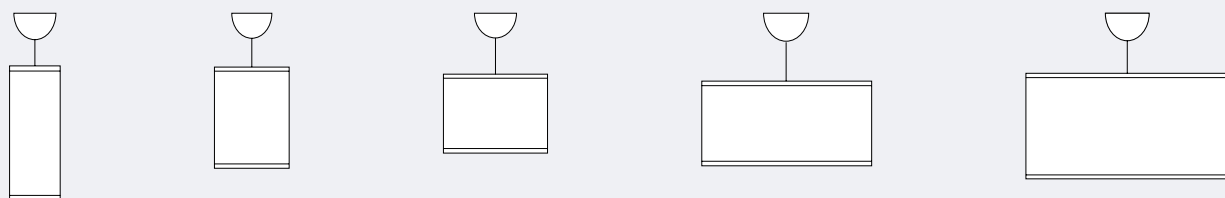

**SOSPENSIONI IN TESSUTO / FABRIC SUSPENSIONS ..... 360 / 363**

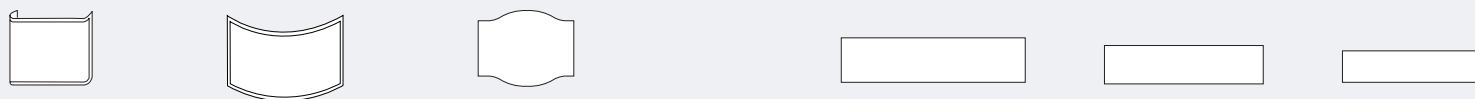

**APPLIQUES IN TESSUTO / FABRIC APPLIQUES ..... 363**

**PLAFONIERE IN TESSUTO / FABRIC CEILINGS ..... 362**

# FAMIGLIE / FAMILIES

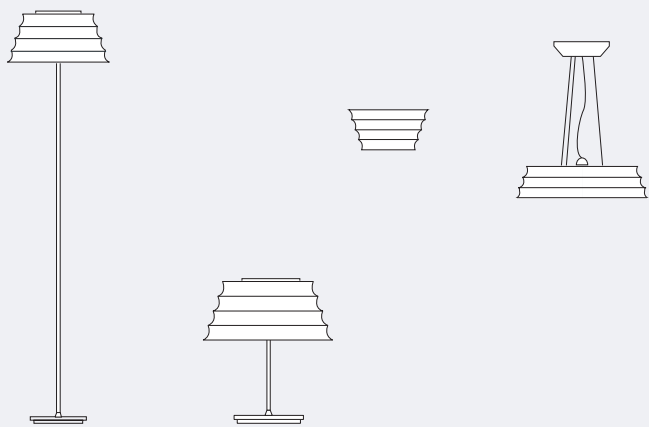

**C'HI**..... **40**

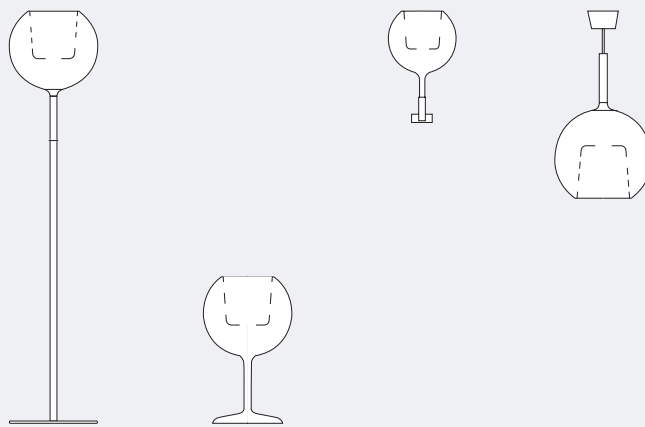

**GLO**..... **100**

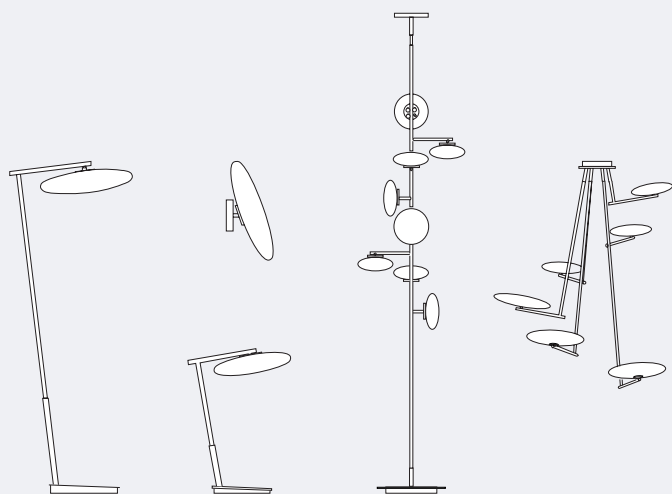

**MAMÌ**..... **180**

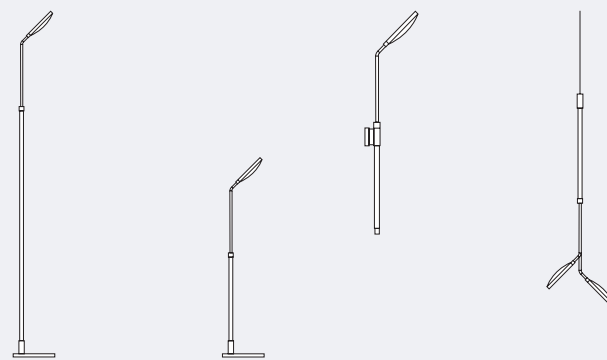

**SPOON**..... **256**







CRISTIÁN MOHADED 2018

# ANGOLO

*Between essentiality — and solidness*

Un elemento illuminante dalle linee essenziali e una struttura monoblocco in pietra o legno: Angolo è una scultura di luce che unisce sapientemente pulizia delle forme e ricchezza materica, per atmosfere sofisticate sia all'interno che all'esterno.

A single illuminating element with essential lines and a stone or wood monobloc: Angolo is a light sculpture combining cleanliness of shapes and material richness, to create an elegant atmosphere, both indoors and outdoors.

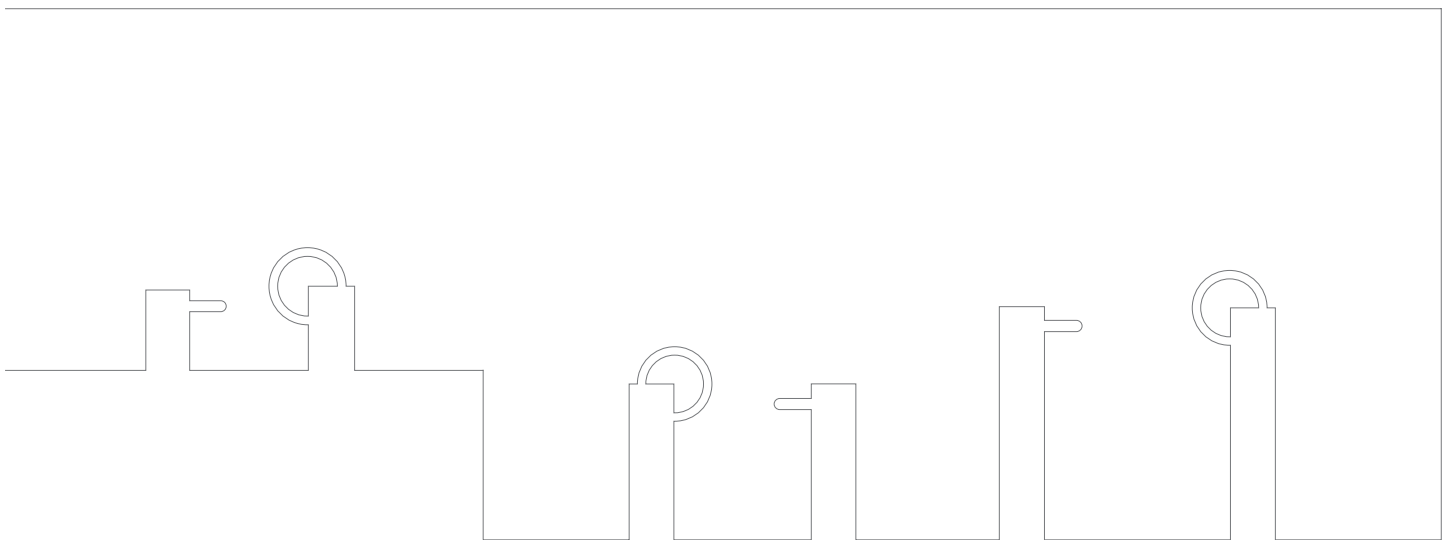



















# ANGOLO *Cristián Mohaded, 2018*

## 1832

Lampada da terra con anello verticale o orizzontale in metallo verniciato opaco nei colori oro, oro rosa e grafite. Base in marmo Emperador spazzolato, Ceppo grezzo o cemento con protezione IP65 per outdoor. Base in legno rovere grafite o rovere cognac con protezione IP20 per indoor.

Floor lamp with vertical or horizontal metal ring in graphite, gold and pink gold matt finishes. Base in brushed Emperador marble, Ceppo raw, cement with protection IP65 for outdoor. Base in cognac or graphite oak with protection IP20 for indoor.

### STRUTTURA / STRUCTURE IP65



### STRUTTURA / STRUCTURE IP20

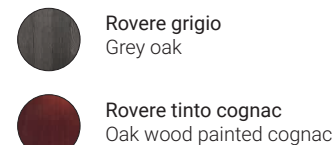

### ANELLO / RING



### SORGENTE / SOURCE

9 W LED 3000 K - 1100 lm  
Dimmer 1-10V

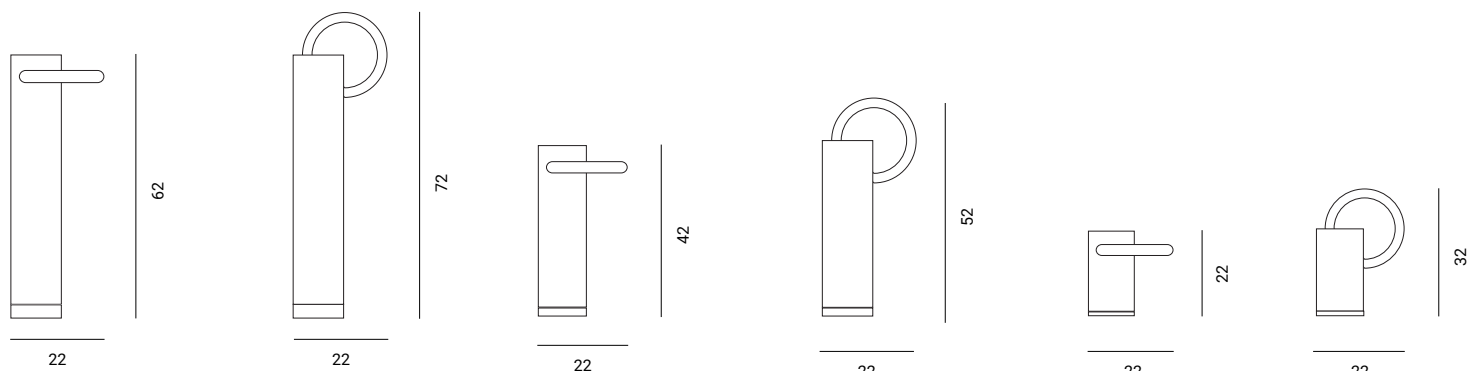

**1832-1W**  
large horizontal  
IP65

**1832-1J**  
large vertical  
IP65

**1832-1K**  
medium horizontal  
IP65

**1832-1Z**  
medium vertical  
IP65

**1832-1Y**  
small horizontal  
IP65

**1832-1X**  
small vertical  
IP65

**1832-15**  
large horizontal  
IP20

**1832-14**  
large vertical  
IP20

**1832-13**  
medium horizontal  
IP20

**1832-12**  
medium vertical  
IP20

**1832-11**  
small horizontal  
IP20

**1832-10**  
small vertical  
IP20

MATTEO BIANCHI 2015

# ACORN

*The unbearable lightness — of concrete*

La materialità del cemento si fonde con la leggerezza del vetro nella lampada a sospensione Acorn, nata per illuminare gli spazi all'esterno e protagonista di quelli all'interno. Il cemento, spatolato a mano, fa filtrare una luce calda e avvolgente.

The materiality of concrete merges with the lightness of glass in the suspension lamp Acorn, born to illuminate outdoor spaces yet protagonist indoors.  
The hand trowelled concrete leaks a warm, enveloping light.

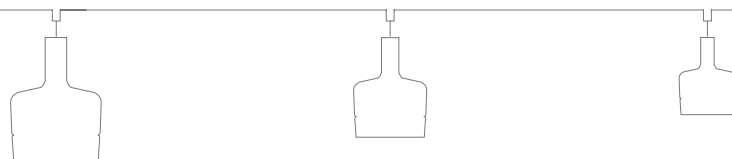













# ACORN *Matteo Bianchi, 2015*

## 1501

Lampada sospensione con diffusore in cemento e vetro satinato o trasparente. Protezione IP44 contro gli spruzzi d'acqua da ogni direzione. Disponibile in tre dimensioni: large, medium e mini. Utilizzabile come elemento singolo o multiplo.

Pendant lamp with shade in concrete and frosted or transparent glass. Protection IP44 against water from any direction. Available in three sizes: large, medium and mini, as single element or in cluster.

## STRUTTURA / STRUCTURE

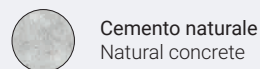

## VETRO / GLASS

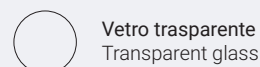
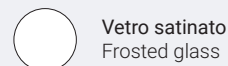

## SORGENTE / SOURCE

**1501-23**  
20 W LED 3000 K - 1700lm  
Dimmable Triac / 0-10V

**1501-22**  
15W LED 3000 K - 1300lm  
Dimmable Triac / 0-10V

**1501-21**  
8W LED 3000 K - 650lm  
Dimmable Triac / 0-10V

## SOSPENSIONE / SUSPENSION

**1501-23**  
large

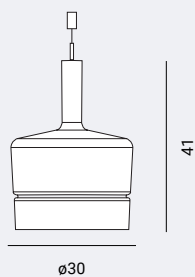

**1501-22**  
medium

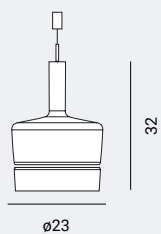

**1501-20**  
mini

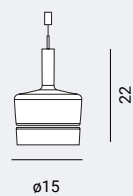

**Rosone**  
Canopy

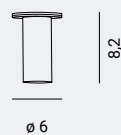

**Piastre a pag. 364**  
plates p. 364

NICOLA GALLIZIA 2017

# APRILE

*Light — in April*

Un quadro luminoso capace di far vibrare le pareti con una luce delicata come quella del sole in primavera. Aprile è un'applicque liberamente orientabile che esplora l'eleganza della luce, più intensa da un lato e più morbida dall'altro.

A luminous painting, capable of making the walls vibrate with a delicate light such as the sun in spring. Aprile is a freely adjustable wall lamp which explores the deep elegance of light, more intense on one side and softer on the other.









*Exploring —  
the deep elegance of light*









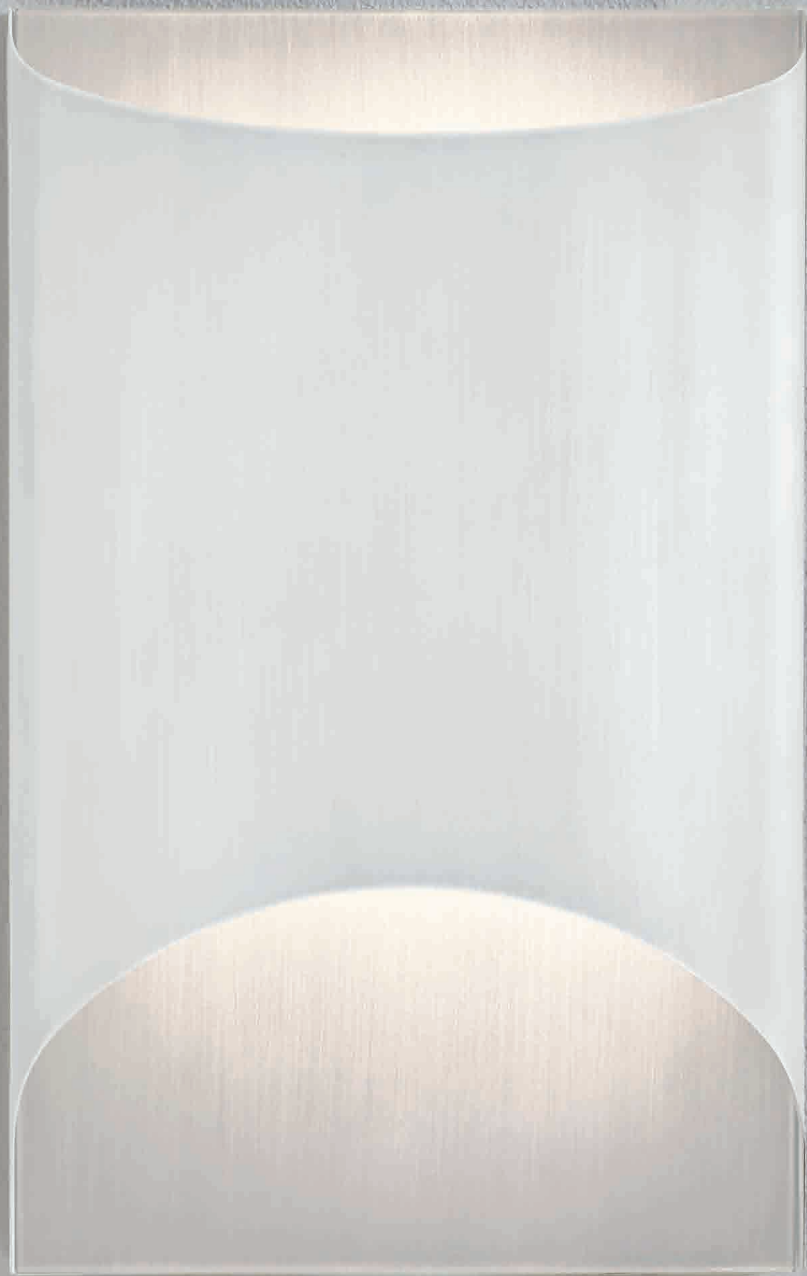

# APRILE *Nicola Gallizia, 2017*

**1649**

Applique realizzata in metallo nelle finiture: acciaio spazzolato, bronzo spazzolato e verniciato bianco.

Wall lamp with metal structure in the finishes: brushed steel, brushed bronze and white varnished.

## STRUTTURA / STRUCTURE

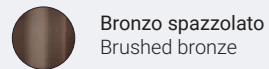
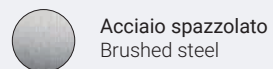

## SORGENTE / SOURCE

2x6W LED 3000 K - 2x600 lm  
Dimmable Triac / 0-10V

## APPLIQUE / WALL

**1649-30**

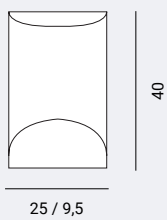

**1649-31**

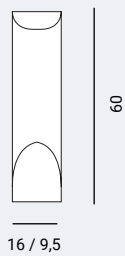

CARLO COLOMBO 2007

# B A G

*A monolith — of light*

Prima lampada da esterni della collezione, Bag è un abat-jour in versione maxi realizzato in espanso termoplastico. Un volume monolitico e imponente per una luce di grande atmosfera.

First outdoor lamp of the collection, Bag is a giant version of a table lamp, made in thermo-plastic. A monolithic and imposing volume for a light that creates great atmosphere.







# BAG *Carlo Colombo, 2007*

## 0802

Lampade da esterno in espanso termoplastico nei colori lucidi bianco e nero. Protezione IP44.

Outdoor lamps in thermo-plastic expansion in the glossy colours: white, black. Protection IP44.

## STRUTTURA / STRUCTURE

 **Bianco lucido**  
Glossy white

 **Nero lucido**  
Glossy black

## SORGENTE / SOURCE

1 x 5W LED E14 sup.  
2 x 5W LED E14 inf.

## TERRA / FLOOR

### 0802-1X

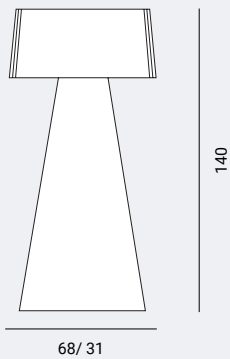

UMBERTO ASNAGO 1999

# C ' H I

*Play of shadows — play of light*

Un classico della nostra collezione, C'hi si riconosce dal paralume in vetro, che con le sue onde delicate disegna luci e ombre sulle pareti e nello spazio. Una famiglia completa formata da lampade a sospensione, da tavolo, da terra e applique.

You can recognize our classic C'hi by its glass shade that, with its delicate waves, gently plays with lights and shadows on the walls and in the space. A complete collection of suspension, table, floor and wall lamps.

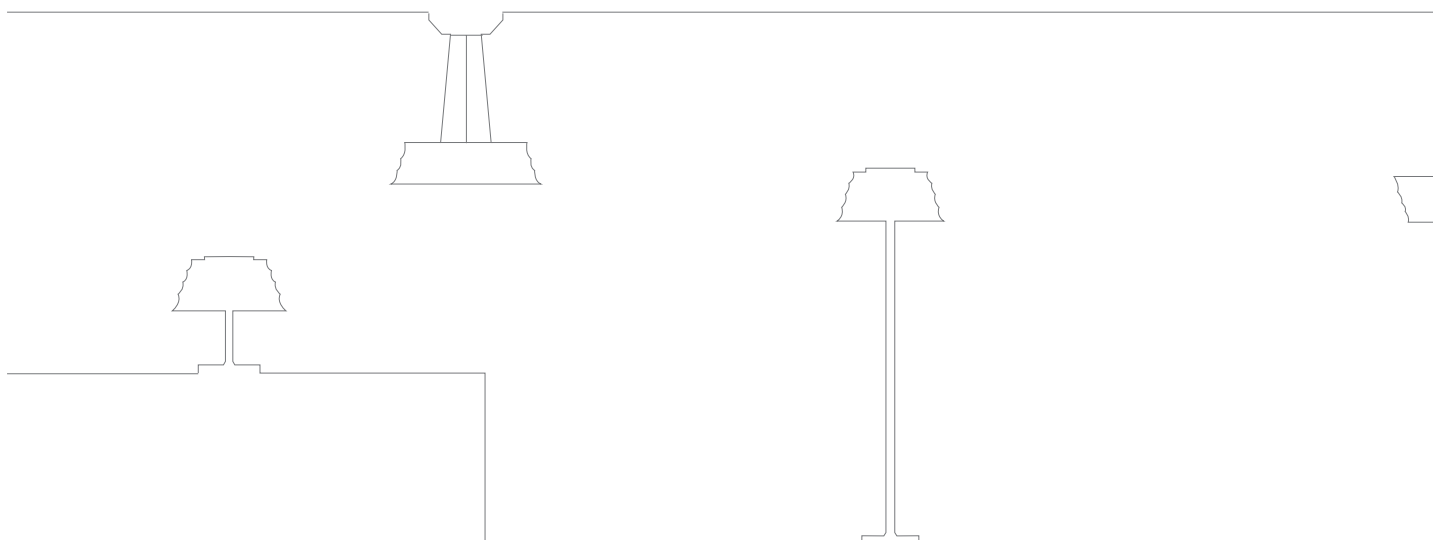







*Delicate waves gently  
— play with lights*

























# C'HI *Umberto Asnago, 1999*

## 9907

Lampade con struttura in metallo nichel satinato. Diffusore esterno in vetro soffiato nei colori: argento, trasparente, bianco, sabbia. Diffusore interno in vetro acidato.

Lamps with structure in nickel satin metal. Outer shade in blown glass in the following colours: silver, transparent, white, sand. Inner shade in mat glass.

## STRUTTURA METALLO / METAL STRUCTURE

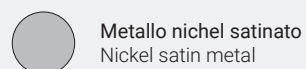

## DIFFUSORE ESTERNO / OUTER SHADE

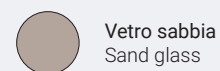
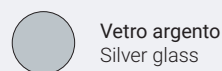
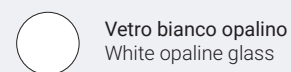
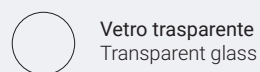

## SORGENTE / SOURCE

**9907-03**  
1 x 10W LED E27

**9907-24**  
3 x 10W LED E27

**9907-02**  
1 x 10W LED E27

**9907-23**  
1 x 10W LED E27

**9907-01**  
1 x 5W LED E14

**9907-22**  
1 x 10W LED E27

**9907-10**  
1 x 10W LED E27 

**9907-21**  
1 x 5W LED E14

**9907-33**  
1 x 16W LED R7s 117 mm

**9907-31**  
1 x 16W LED R7s 117 mm

## TAVOLO / TABLE

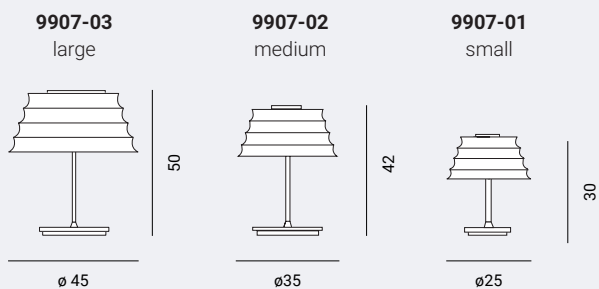

## SOSPENSIONI / SUSPENSION

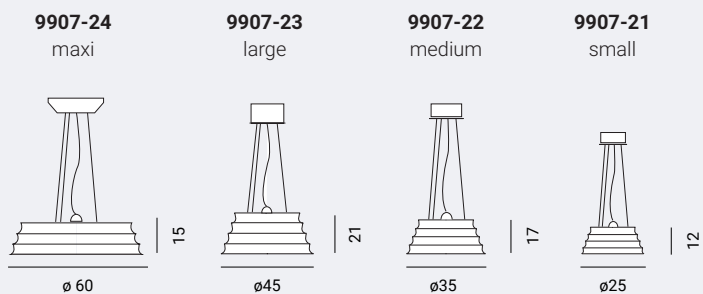

## APPLIQUE / WALL

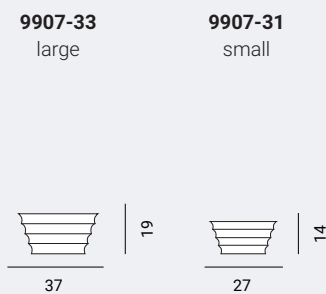

## TERRA / FLOOR

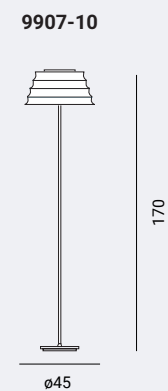

NICOLA GALLIZIA 2003-2007  
PREMIO 2008: GOOD DESIGN AWARD

# CHINA

*The beauty — of a soft light*

Un'elegante lampada da lettura che diffonde una luce soffusa grazie al basamento riflettente. La ricchezza delle finiture, dal bianco lucido all'oro, permette di interpretare China in modo sempre diverso a seconda del contesto.

An elegant reading lamp which spreads a soft light through its reflecting base. The different finishings, from glossy white to gold, allow to interpret China in a way that is always different, according to the context.

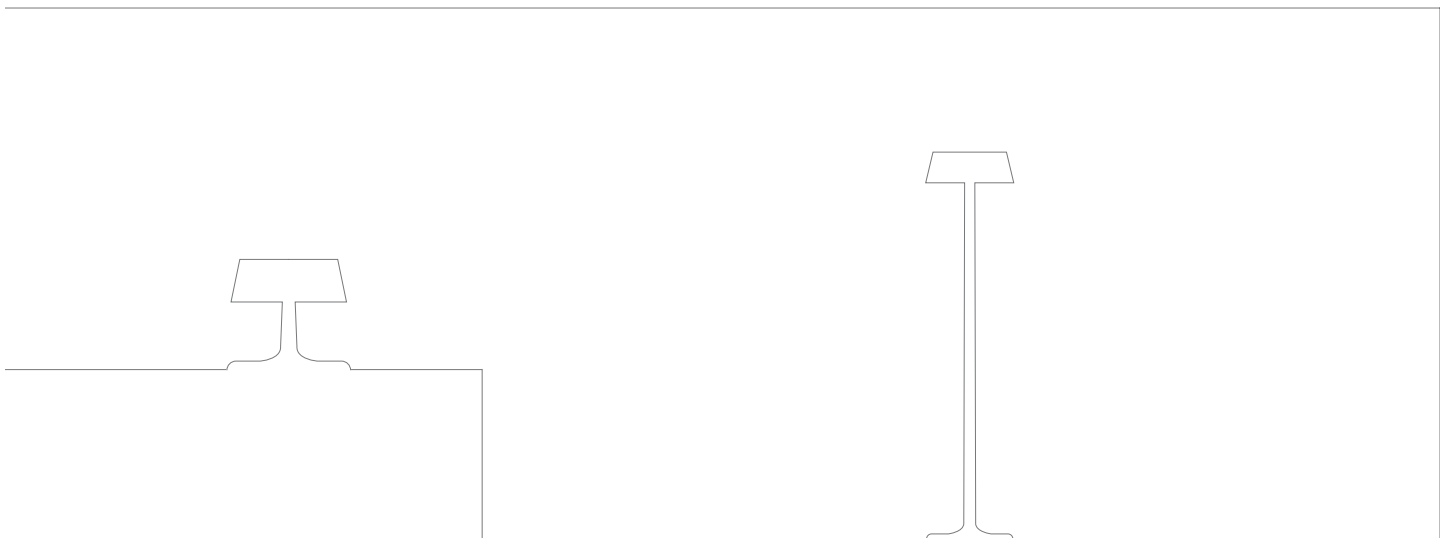







*Always different,  
— according to the context*















Bianco lucido  
Glossy white



Grafite opaco  
Mat graphite



Maron glacé opaco  
Mat maron glacé



Rosso opaco  
Mat red







# CHINA *Nicola Gallizia, 2003/2007*

## 0308

Lampade con struttura in metallo tornito in lastra. Verniciato opaco nei colori: rosso, maron glacé, bronzo, oro, oro rosa, grafite. Verniciato bianco lucido.

Lamps with metal structure. Matt varnished in the colours: red, maron glacé, bronze, gold, rose gold, graphite and glossy white varnished.

## STRUTTURA METALLO / METAL STRUCTURE

 Bianco lucido  
Glossy white

 Bronzo opaco  
Mat bronze

 Grafite opaco  
Matt graphite

 Oro opaco  
Matt gold

 Rosso opaco  
Mat red

 Oro rosa opaco  
Matt rose gold

 Maron glacé opaco  
Mat maron glacé

## SORGENTE / SOURCE

**0308-00**  
3 x 5W LED E14 

**0308-12**  
3 x 5W LED E14 

**0308-01**  
2 x 5W LED E14

**0308-11**  
3 x 5W LED E14 

## TAVOLO / TABLE

**0308-00**  
medium

**0308-01**  
small

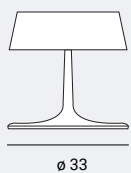

32

ø 33

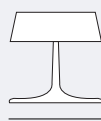

22,5

ø 23

## TERRA / FLOOR

**0308-12**  
high

**0308-11**  
low



160

ø 33



115

ø 33

# CLASH

*Modern shapes — futuristic finishings*

Clash è un'applique che combina la leggerezza del vetro e la forza del metallo per creare un oggetto dall'estetica moderna e sofisticata, reso futuristico dalle finiture in peltro e bronzo. La parte inferiore è orientabile, una caratteristica funzionale prima che estetica.

Clash is a wall lamp combining the lightness of glass and the strength of metal to create a modern and sophisticated object, with a futuristic touch given by pewter and bronze finishings. The lower part is adjustable, a functional feature rather than an aesthetic one.

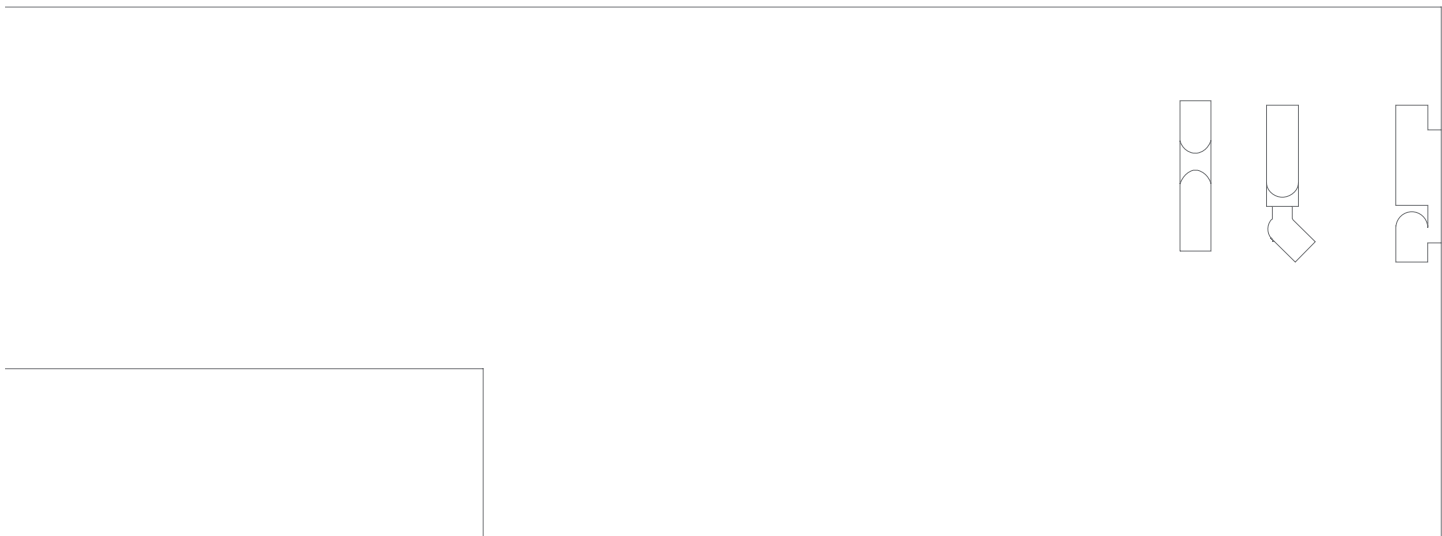





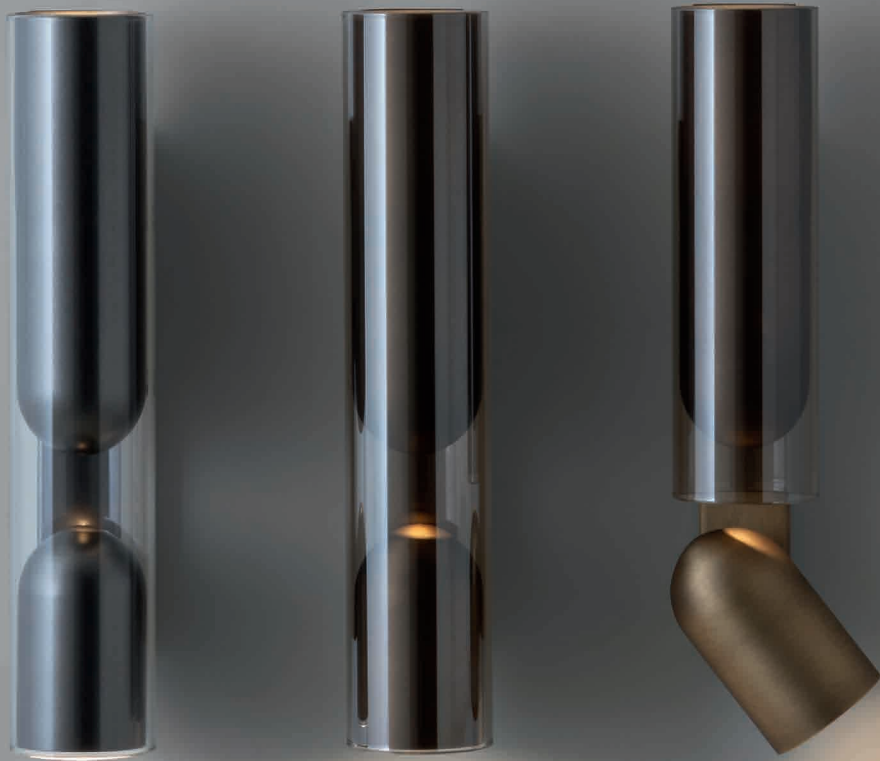

# CLASH *Artefatto, 2017*

## 1699

Applique con struttura interna in metallo nelle finiture grafite o bronzo spazzolato e struttura esterna in vetro trasparente o fumé.

Wall lamp with inner structure in metal in the finishes graphite or brushed bronze and outer structure in transparent or fumé glass.

## STRUTTURA METALLO / METAL STRUCTURE

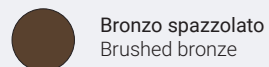
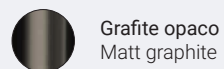

## VETRO / GLASS

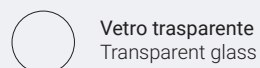

## SORGENTE / SOURCE

**1699-30**  
2x 6W LED GU10

**1699-31**  
2x 6W LED GU10

## APPLIQUE / WALL

1699-30

1699-31

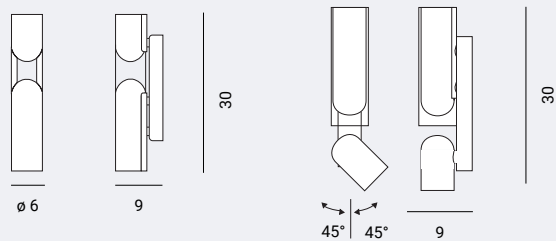

# CLIP

*Light — as a necklace*

Clip è una collezione di lampade a sospensione caratterizzata da un disco sottile accoppiato a un'asola, aperta o chiusa, agganciata al cavo di sostegno. Un accessorio dall'estetica contemporanea, un sofisticato gioiello da soffitto.

Clip is a collection of suspension lamps defined by a thin disc coupled with a slot, open or closed, hooked to the support cable.

An accessory from contemporary aesthetics, a glamorous ceiling jewel.

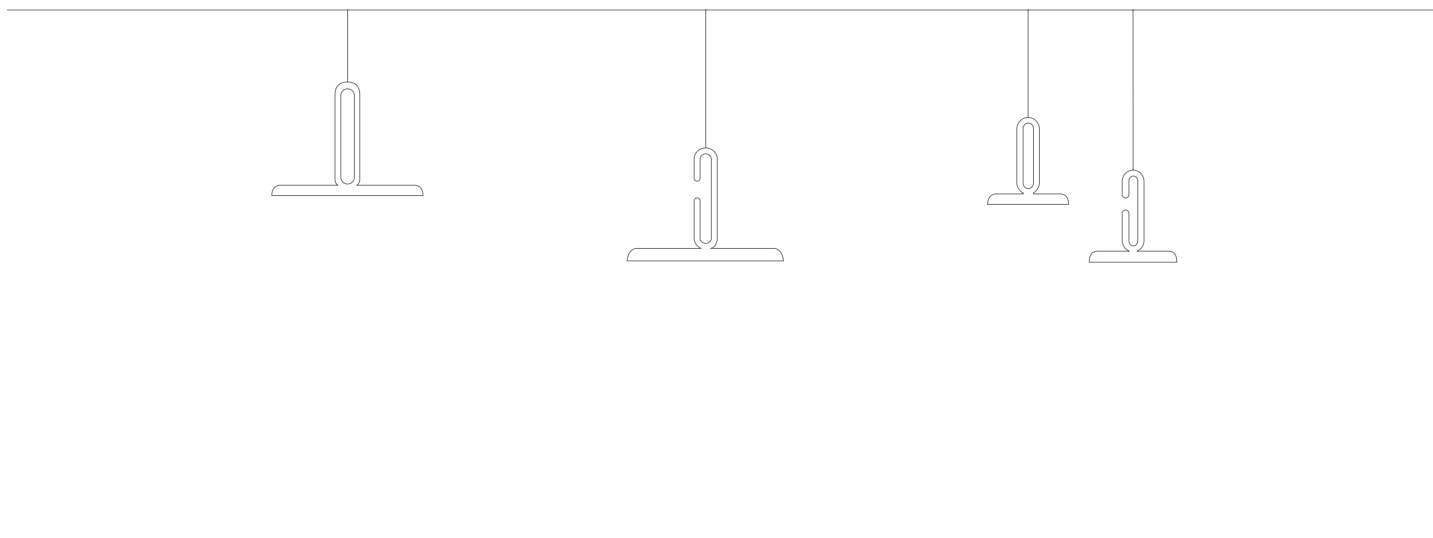







*A contemporary and glamorous  
— ceiling jewel*









# CLIP *Daniel Debiasi & Federico Sandri, 2017*

## 1707

Sospensioni con struttura in metallo nelle finiture lucide o opache: oro, oro rosa e grafite. Disponibile con anello aperto o chiuso, in due dimensioni, large o mini. Rosone singolo nelle stesse finiture della struttura. Utilizzabile come elemento singolo o multiplo.

Pendant lamps with metal structure in glossy or matt finishes: gold, rose gold and graphite. Available with open or close ring, in two sizes, large or mini. Single canopy in the same finishes of the structure. Available as single element or in cluster

## STRUTTURA METALLO / METAL STRUCTURE



Oro lucido o opaco  
Glossy or matt gold



Oro rosa lucido o opaco  
Glossy or matt rose gold



Grafite lucido o opaco  
Glossy or matt graphite

## SORGENTE/ SOURCE

**1707-24**  
16W LED 3000 K- 1900 lm

**1707-22**  
7W LED 3000 K- 850 lm

**1707-23**  
16W LED 3000 K- 1900 lm

**1707-21**  
7W LED 3000 K- 850 lm

## SOSPENSIONE / SUSPENSION

**1707-24**  
large open

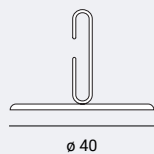

**1707-23**  
large closed

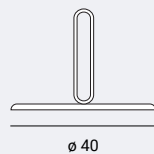

**1707-22**  
mini open

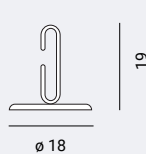

**1707-21**  
mini closed

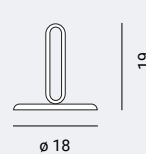

**Rosone**  
canopy



**Piastre a pag. 364**  
plates p. 364

CARLO COLOMBO 2017

# ELISABETH

*The precious side — of light*

Un gioco astronomico di semisfere ispira la collezione Elisabeth – dalla più composta versione da tavolo alle suggestioni art déco della sospensione.

Metalli lucidi e marmo di Carrara impreziosiscono la pulizia formale dei volumi.

Elisabeth collection is inspired by an astronomical game of hemispheres: from the linear version of the table lamp to the suspension lamp, reminiscent of art deco. The formal cleanliness of the volumes is enriched by glossy metal and Carrara marble.

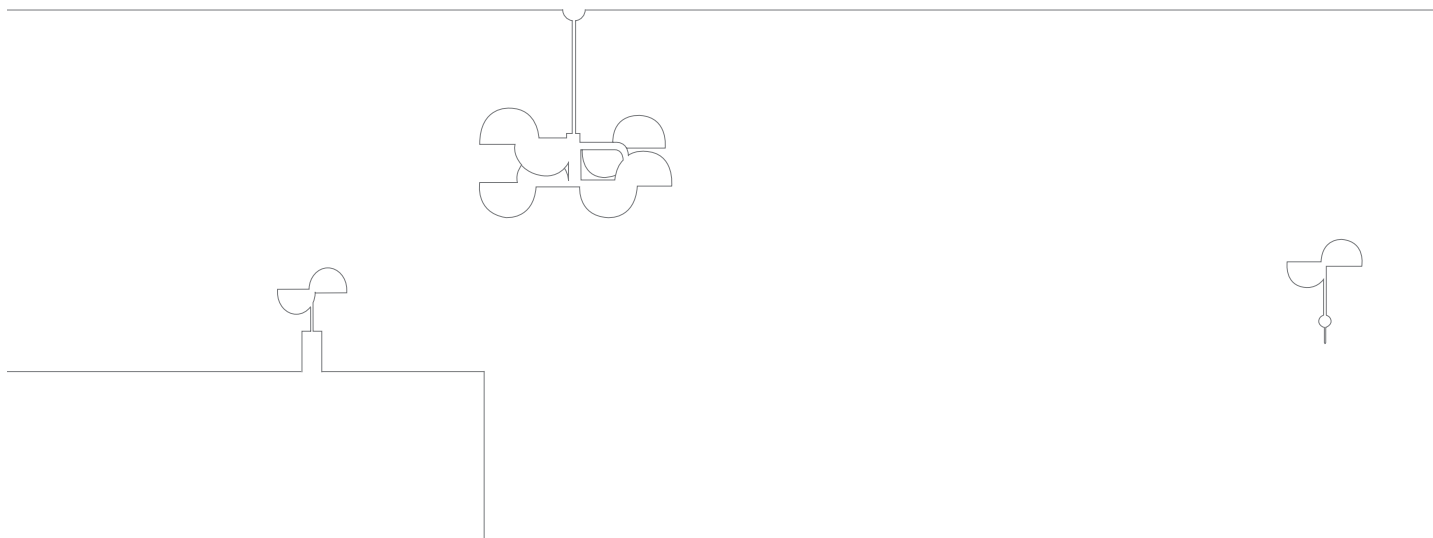













VENICE





















# ELISABETH *Carlo Colombo, 2017*

## 1711

Lampade con struttura in metallo nichel nero lucido.  
Lampada da tavolo disponibile con base in marmo bianco di Carrara  
o con base in metallo.

Lamps with structure in glossy black nickel. Table lamp available with  
base in Carrara white marble or in metal.

## STRUTTURA METALLO / METAL STRUCTURE

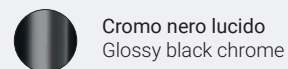

## BASE / BASE

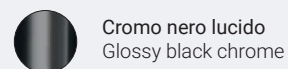
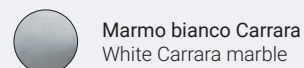

## SORGENTE / SOURCE

**1711-03**  
2 x 8W LED 3000 K - 2x650 lm

**1711-23**  
8 x 10W LED 3000 K - 8x900 lm

**1711-01**  
2 x 6W LED 3000 K - 2x450 lm

**1711-21**  
4 x 10W LED 3000 K - 4x900 lm

**1711-30**  
2 x 6W LED 3000 K - 2x450 lm

## TAVOLO / TABLE

**1711-03**  
large

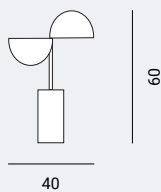

**1711-01**  
small

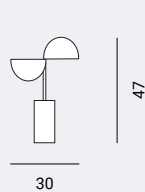

## SOSPENSIONE / SUSPENSION

**1711-23**  
large

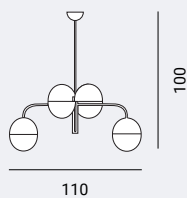

**1711-21**  
small

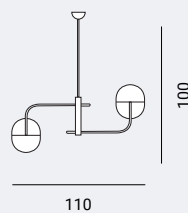

## APPLIQUE / WALL

**1711-30**

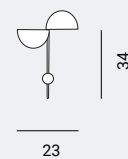

DEBIASI & SANDRI 2017

# ENOKI

*The splendour — of art deco*

Applique che riprende forme art déco combinando una lamina di metallo a una semicupola sporgente, Enoki vive come oggetto singolo o combinata ad altri elementi simili, anche con orientamenti diversi.

Resuming shapes from art deco, this wall lamp combines a metal sheet with a protruding half-dome. Enoki can be a single design object or combined with other similar elements, assembled with different orientations.

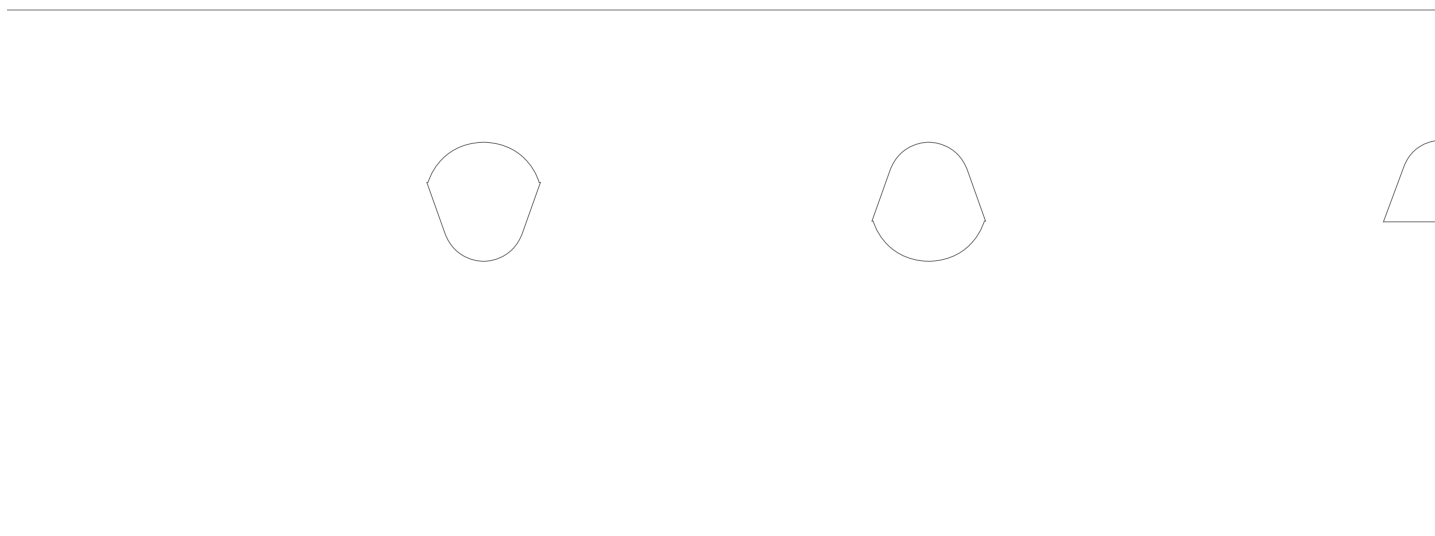











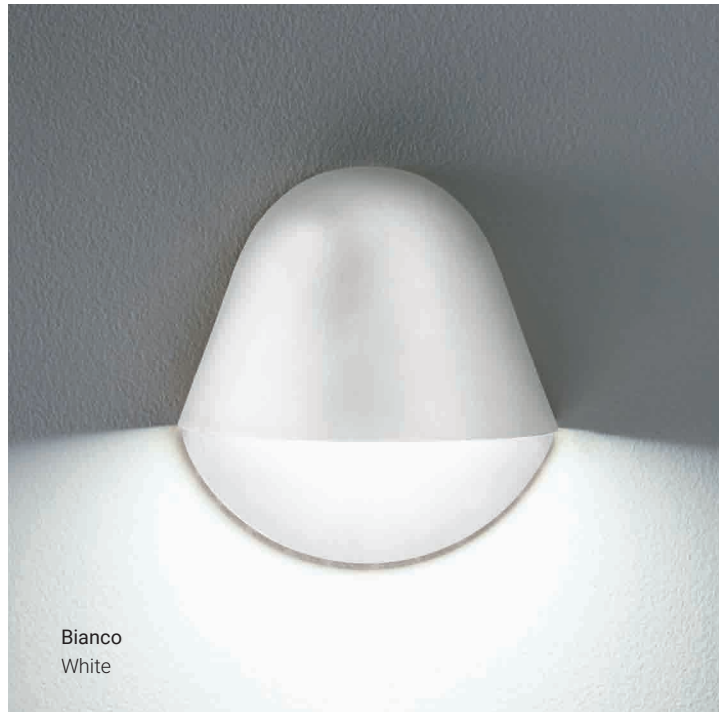
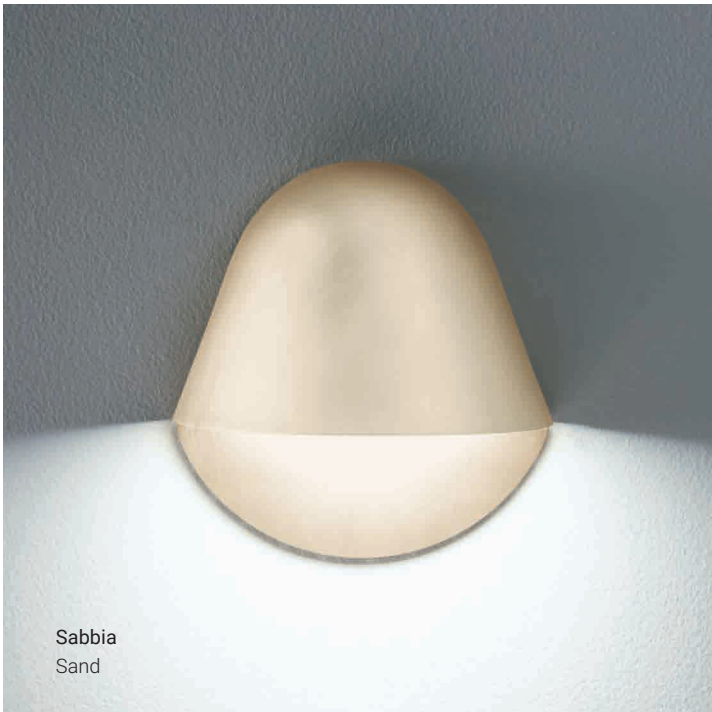



# ENOKI *Daniel Debiasi & Federico Sandri, 2017*

## 1708

Applique realizzata nelle finiture verniciate opache oro, oro rosa, grafite, sabbia e bianco.

Wall lamp in the matt varnished finishes gold, rose gold, graphite, sand and white.

## FINITURE OPACHE / MATT FINISHES



Oro  
Gold



Sabbia  
Sand



Oro rosa  
Rose gold



Bianco  
White



Grafite  
Graphite

## SORGENTE / SOURCE

### 1708-30

10W LED 3000 K - 800 lm  
Dimmable Triac

## APPLIQUE / WALL

### 1708-30

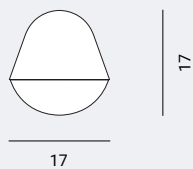

SARA MORONI 2018

# F E E L

*Light — of silence*

Feel nasce dalla combinazione di dischi tessili fonoassorbenti e steli luminosi. I dischi colorati, in tinta o a contrasto tra loro, danno vita a configurazioni sempre diverse, da sospendere al soffitto o fissare a parete per assorbire i rumori e godersi il silenzio.

Feel comes from the combination of sound absorbing textile discs and luminous stems. The coloured discs, in matching or contrasting colours, give life to ever-changing configurations, to be suspended from the ceiling or fixed to the wall, in order to absorb noise and enjoy silence.

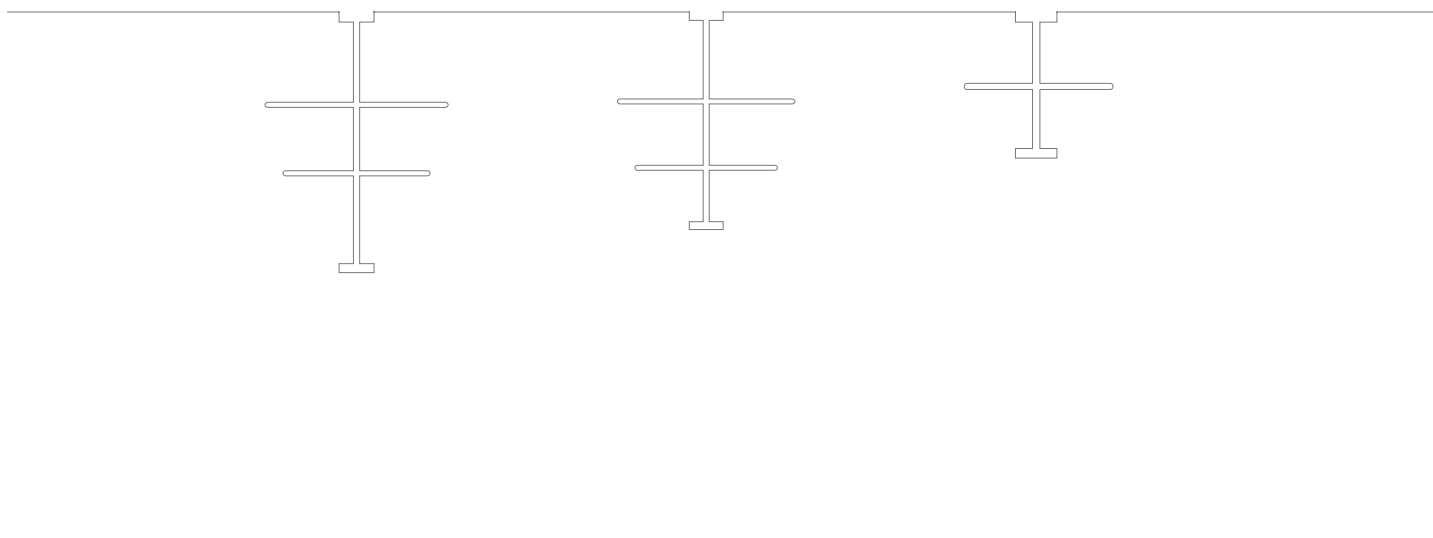









*Acoustic solution —*













# FEEL *Sara Moroni, 2018*

## 1831

Sospensione modulare con struttura in metallo in tre dimensioni e nelle finiture opache grafite, oro e oro rosa. Dischi in tre diametri, in tessuto fonoassorbente nei colori: bordeaux, blu scuro, petrolio, mattone, sabbia, grigio chiaro, verde scuro. I dischi sono disponibili anche come singolo elemento decorativo, senza luce. Prodotto innovativo che unisce l'illuminazione con la tecnologia della fonoassorbenza. Feel, riducendo il fastidioso riverbero acustico, consente di vivere e lavorare in ambienti meno rumorosi e più confortevoli.

Modular suspension with metal structure in three sizes available graphite, gold and pink gold matt finishes. Sound-absorbing fabric discs are available in three diameters with the following colors: bordeaux, dark blue, petroleum, brick, sand, light grey, dark green. Discs are also available as a single decorative element, without light. Innovative product which mix together lighting and sound proofing technology. Feel, reducing the annoying acoustic reverberation, allows to live and work in quiet and more comfortable spaces.

## STRUTTURA METALLO / METAL STRUCTURE

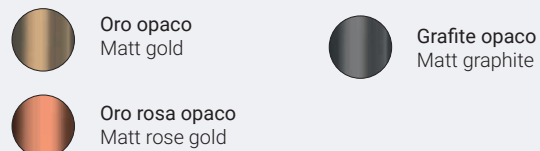

## FINITURE TESSUTO / TEXTILE FINISHES



## SORGENTE / SOURCE

27W LED 3000 K - 3500 lm 

## SOSPENSIONE / SUSPENSION

**1831-23**  
large



**1831-22**  
medium

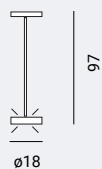

**1831-21**  
mini

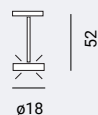

**1831-98**  
medium



**1831-97**  
mini



**1831-93**  
large

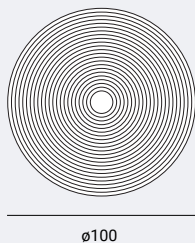

**1831-92**  
medium

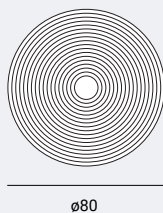

**1831-91**  
mini

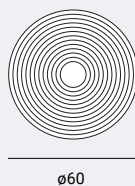

## ACCESSORI VERSIONE CIECA / BLIND VERSION ACCESSORIZES









CARLO COLOMBO, 2009-2015

# GLO

*Glass glares — and reflections*

Glo è un'icona della nostra collezione, una sfera di vetro che esalta il riverbero della luce, in un gioco di riflessioni e rimandi tra la lampada e lo spazio o fra le lampade tra loro. La ricca palette e le diverse misure della variante sospesa sono un invito alla composizione.

Glo is an icon of our collection, a glass sphere enhancing the glare of light, in a game of reflections back and forth between the lamp and the space or among the very lamps. The rich palette of colours and the different dimensions of the suspension lamps are a toast to creativity.

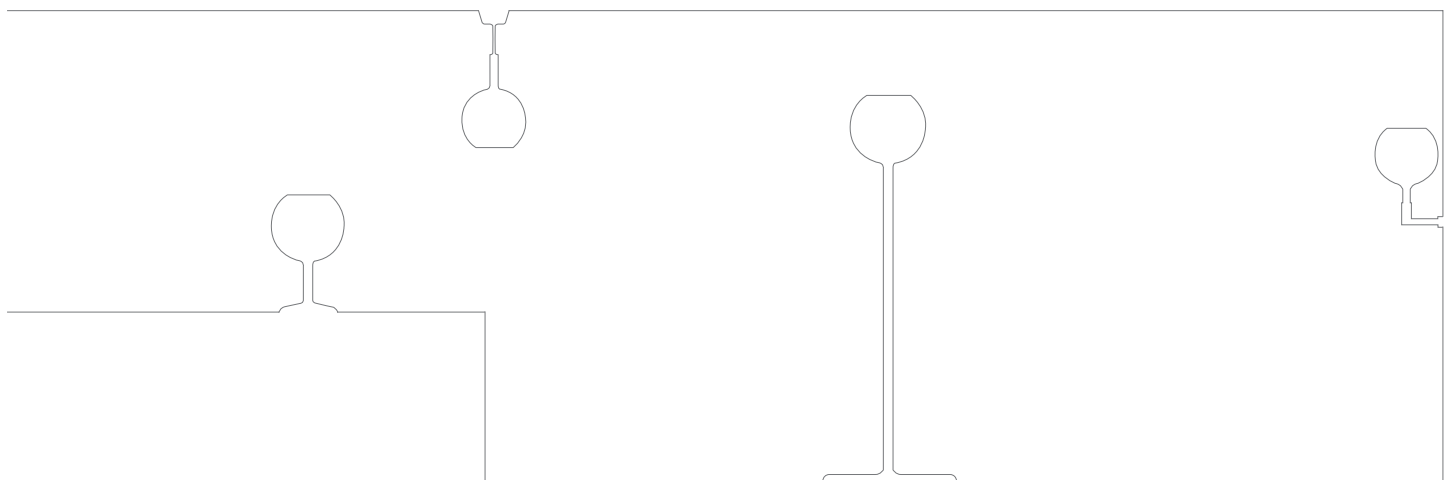









*A glass sphere enhancing  
the glare — of light*







Nuovi colori  
New colors



Viola  
Violet

Verde  
Green

Blu  
Blue























Argento / Silver

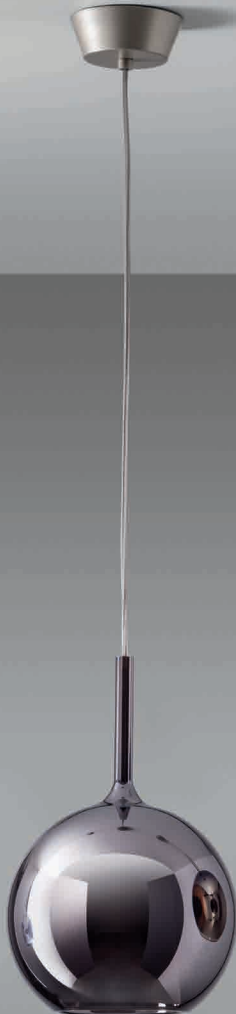

Nera / Black



4 Ever

SPENTA / OFF



Argento / Silver

Nera / Black

4 Ever

ACCESA / ON



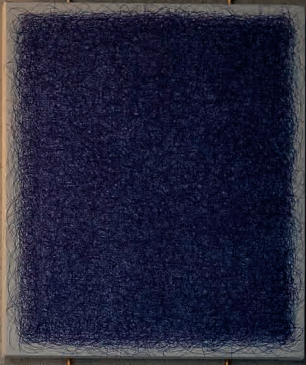
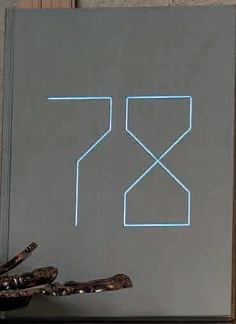









Oro rosa  
Rose gold





















## 0811

Lampade con struttura in metallo cromato lucido e vetro borosilicato. Diffusore esterno: trasparente, oro, argento, oro rosa, nero, 4ever, blu, verde, viola. Diffusore interno sabbiato. Rosone a soffitto in titanio e bianco.

Lamps with chromed metal structure and borosilicate glass. Outer shade transparent, gold, silver, rose gold, black, 4ever, blue, green, violet. Inner shade sandblasted. Canopy in titanium and white.

### TAVOLO / TABLE

**0811-03**  
Large

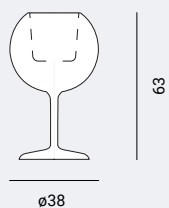

**0811-01**  
Medium

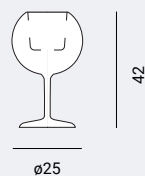

**0811-00**  
Mini

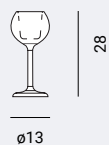

### TERRA / FLOOR

**0811-10**

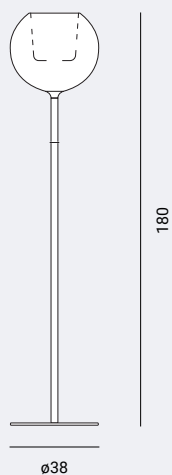

### SOSPENSIONE / SUSPENSION

**0811-23**  
Large

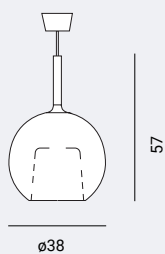

**0811-21**  
Medium

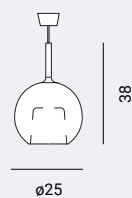

**0811-20**  
Mini

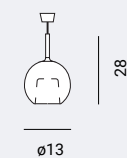

**Rosone**  
canopy

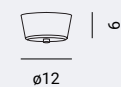

**Piastre a pag. 364**  
plates p. 364

### APPLIQUE / WALL LAMP

**0811-31**  
Medium

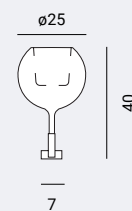

**0811-30**  
Mini

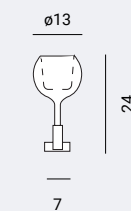

**STRUTTURA METALLO APPLIQUES/ METAL STRUCTURE WALL LAMPS**



Oro opaco  
Matt gold



Grafite opaco  
Matt graphite



Oro rosa opaco  
Matt rose gold



Bianco opaco  
Matt white

**STRUTTURA METALLO TERRA/ METAL STRUCTURE FLOOR LAMP**



Oro lucido  
Glossy gold



Cromo  
Crome

**VETRI SPECCHIATI / MIRRORING GLASSES**



Trasparente  
Transparent



4ever  
4ever



Argento  
Silver



Blu  
Blue



Oro  
Gold



Verde  
Green



Oro rosa  
Rose gold



Viola  
Violet



Nero  
Black

**SORGENTE/ SOURCE** 

**0811-03**  
1 x 10W LED E27



**0811-23**  
1 x 10W LED E27

**0811-01**  
1 x 5W LED E14

**0811-21**  
1 x 5W LED E14

**0811-00**  
1 x 3W LED G9

**0811-20**  
1 x 3W LED G9

**0811-10**  
1 x 10W LED E27



**0811-30**  
1 x 3W LED G9

**0811-31**  
1 x 5W LED E14

UMBERTO ASNAGO 2017

# JACQUELINE

*Light haute couture*

Jacqueline è una lampada portatile dall'allure femminile e giocosa che associa tecnologia e sartorialità: i dettagli in pelle sono cuciti a mano e si abbinano al colore dell'alluminio anodizzato della struttura.

Jacqueline is a portable lamp with a feminine playful wit, which combines technology and tailoring: the leather details are hand sewn and match the colour of the anodized aluminium structure.















*Combining technology  
— and tailoring*













# JACQUELINE *Umberto Asnago, 2017*

## 1709

Lampada da tavolo portatile e ricaricabile con struttura in metallo spazzolato e cuoio nei seguenti abbinamenti: oro/senape, grafite/antracite, rosa cipria/castagna, blu/blu notte.

Disponibile in due dimensioni: large e small e nella versione per outdoor con protezione IP44.

Portable and rechargeable table lamp with structure in brushed metal and leather in the following matchings: gold/ mustard, graphite/ anthracite, powder pink/ chestnut, blue/ night blue.

Available in two sizes, large and small and in the outdoor version with protection IP44.

## METALLO SPAZZOLATO BRUSHED METAL



Oro  
Gold

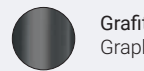

Grafite  
Graphite



Rosa cipria  
Powder pink



Blu  
Blue

## CUOIO LEATHER



Senape  
Mustard



Antracite  
Anthracite



Castagna  
Chestnut



Blu notte  
Night blue

## SORGENTE/ SOURCE

**1709-04**  
13W LED 3000 K - 1500 lm

**1709-03**  
13W LED 3000 K - 1500 lm 

**1709-01**  
6W LED 3000 K - 600 lm 

## TAVOLO / TABLE

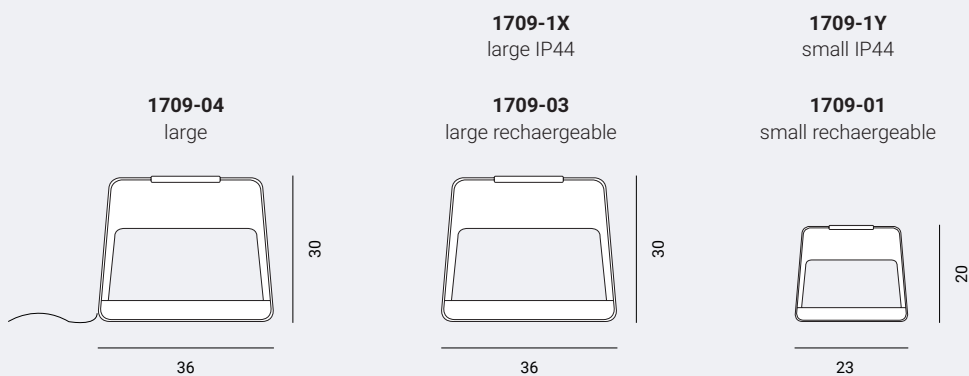



NICOLA GALLIZIA 2005

# J E I J E I

*A contemporary — chandelier*

Reinterpretazione del classico lampadario in vetro, Jei Jei è maestosa ed essenziale. Le canne in vetro borosilicato sottilissimo si innestano nella corona centrale dando vita a composizioni più o meno ricche, anche in versione applique.

Jei Jei is a majestic and essential re-imagining of the classical glass chandelier. The thin borosilicate glass rods engage onto the central crown, giving life to more or less rich compositions, both in the suspension or wall version.

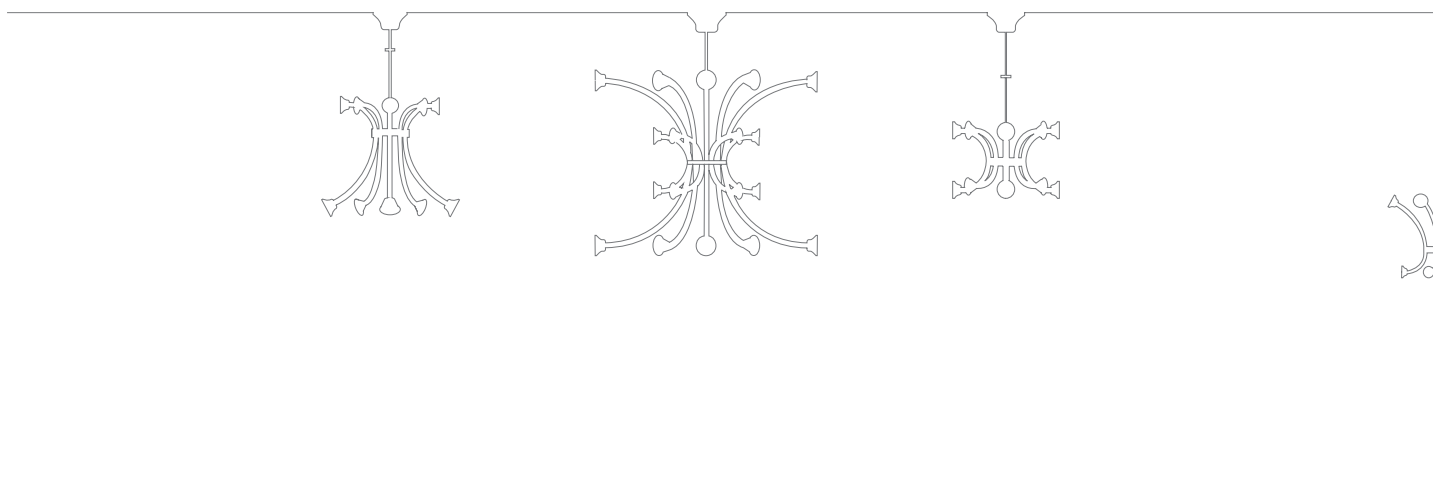





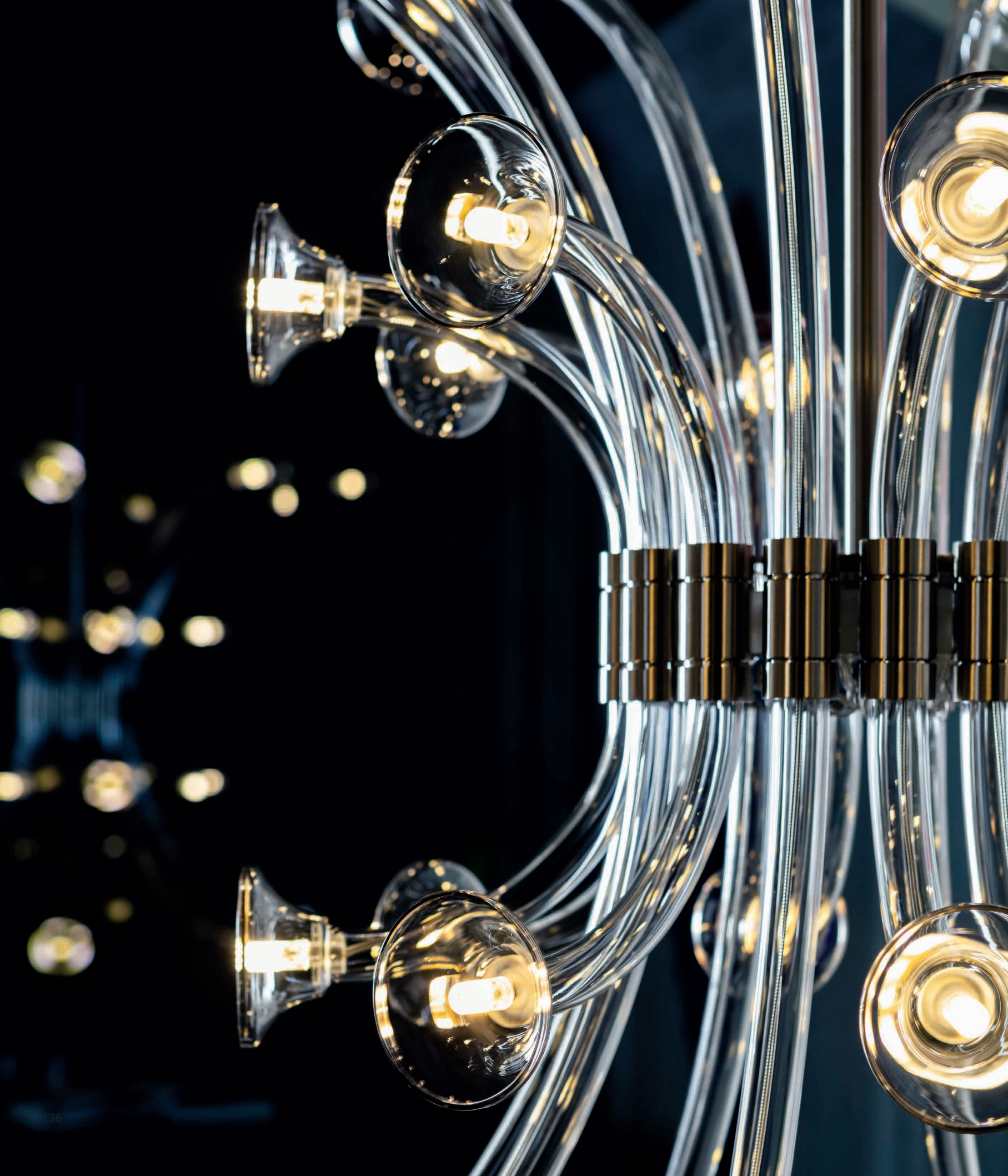







# JEI JEI *Nicola Gallizia, 2005*

## 0501

Lampada sospensione e applique. Struttura in metallo nichel satinato o bronzo con diffusori a braccio modulari grandi, medi e piccoli in vetro borosilicato trasparente (fumé, ambra, oro rosa solo su richiesta)  
A richiesta: versione dimmerabile.

Pendant and wall lamps. Structure in nickel satin metal or bronze with modular large, medium and small arm shades in transparent borosilicate glass (fumé, amber or pink gold only on demand).  
On demand: dimmerable version.

## STRUTTURA IN METALLO / METAL STRUCTURE



Nichel satinato  
Nickel satin



Bronzo spazzolato  
Brushed bronze

## VETRO / GLASS



Trasparente  
Transparent



Fumé \*  
Fumé



Oro rosa \*  
Rose gold



Ambra \*  
Amber

\* su richiesta / on demand

**SORGENTE / SOURCE**

2W - 12V - G4 LED

## SOSPENSIONE / SUSPENSION

**0501-25**  
supermaxi  
48 lights

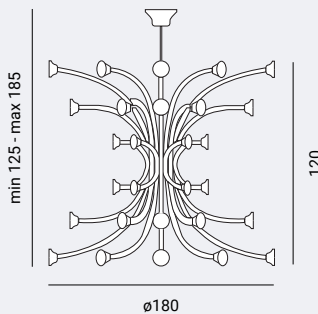

**0501-24**  
maxi  
32 lights

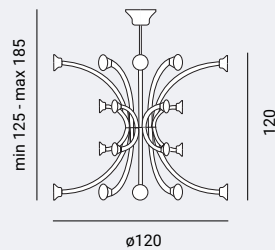

**0501-21**  
small  
16 lights

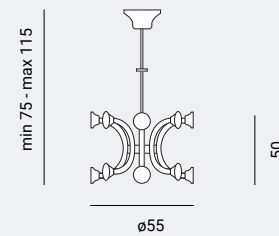

**0501-22**  
medium  
16 lights

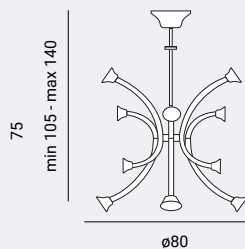
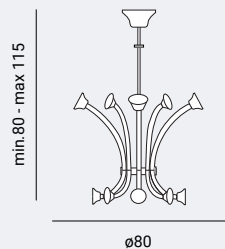
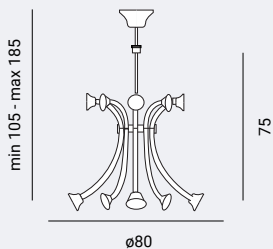

## APPLIQUE / WALL

**0501-33**  
large  
8 lights

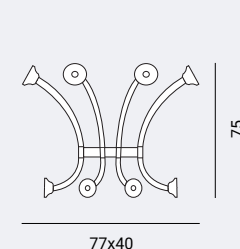

**0501-30**  
small  
6 lights

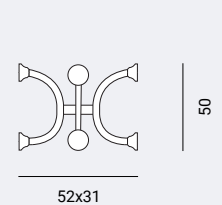



CARLO COLOMBO 2015

# J E S U I S

*Silvery — full moon*

Una lampada scultorea formata da una sfera bicolore in vetro bianco e argento e da un basamento monumentale in marmo di Carrara o legno. Je suis è una dichiarazione d'intenti, tra ricchezza delle finiture e bellezza che supera la funzione.

A sculptural lamp formed by a two-coloured sphere in white and silver glass and by a monumental Carrara marble or wood base. Je suis is a declaration of intents, with its rich finishings and the beauty beyond functionality.

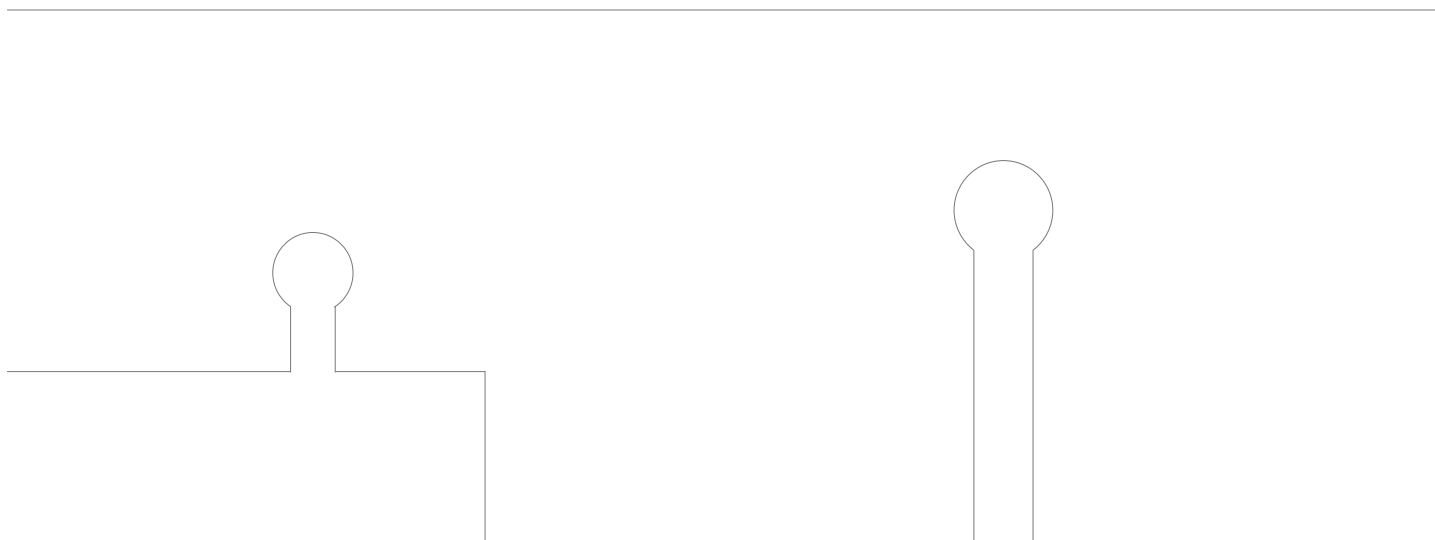

















# JE SUIS *Carlo Colombo, 2015*

## 1502

Lampada da terra e tavolo con base realizzata in: legno rovere, rovere grigio, legno tinto antracite o in marmo bianco di Carrara. Diffusore girevole 360° in vetro soffiato bicolore bianco/argento.

Floor and table lamp with base in: oak, grey oak, stained anthracite wood or Carrara white marble. 360° turning bicolor blown glass shade in white/silver.

## BASE / BASE

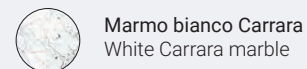
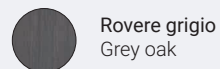
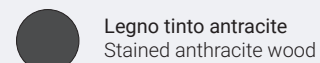
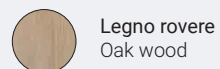

## VETRO / GLASS

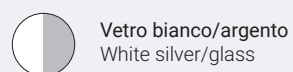

## SORGENTE / SOURCE

17,5W LED 3000 K



## TAVOLO / TABLE

### 1502-03

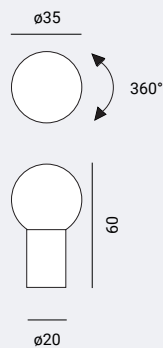

## TERRA / FLOOR

### 1502-10

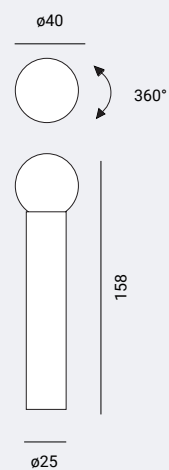

UMBERTO ASNAGO 2015

# KLINT

*Tradition — meets innovation*

Klint è un oggetto scultoreo, un cesto di luce ispirato alla tecnica del vetro a lume della tradizione veneziana. Le canne in tondino di vetro trasparente portano verso l'alto la luce della fonte luminosa a LED.

Klint is a sculptural object, a basket of light inspired by the Venetian lamp-working technique. The transparent glass rods bring up the light from the actual LED light source.

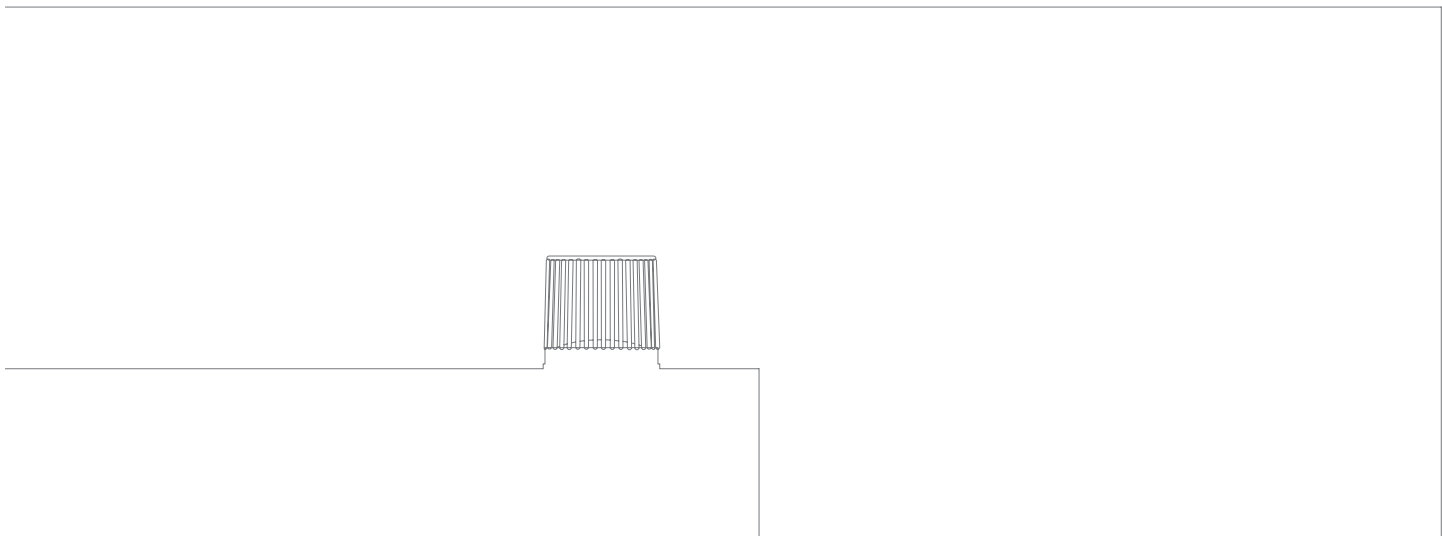



GWATER  
LIVING  
MEYER CASAS  
GG



AND





*A sculptural object  
— a basket of light*









# KLINT

*Umberto Asnago, 2013*

## 1301

Lampade da tavolo realizzate in tondino di vetro trasparente, con base in metallo verniciato grafite. Doppia accensione a led.

Table lamps with structure in transparent glass rod and base in graphite varnished metal. Double led lighting.

## STRUTTURA IN METALLO / METAL STRUCTURE

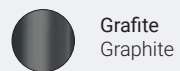

## VETRO / GLASS

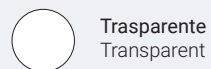

## SORGENTE / SOURCE

14W LED 3200 K + 17W LED 3000K

## TAVOLO / TABLE

### 1301-03

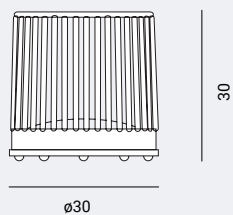

UMBERTO ASNAGO 2018

# LAB

*Outside — in the nature*

Lampada da terra per esterni, Lab è dotata di un dispositivo fotovoltaico per l'autoricarica. Essenziale nelle linee, diffonde una luce indiretta molto calda, in armonia con le ambientazioni più naturali.

Lab is a floor lamp for outdoors, which comes with a solar panel for self charging. With its essential lines, it spreads a very warm indirect light, in perfect harmony with a natural setting.











*In perfect harmony  
— with a natural setting*





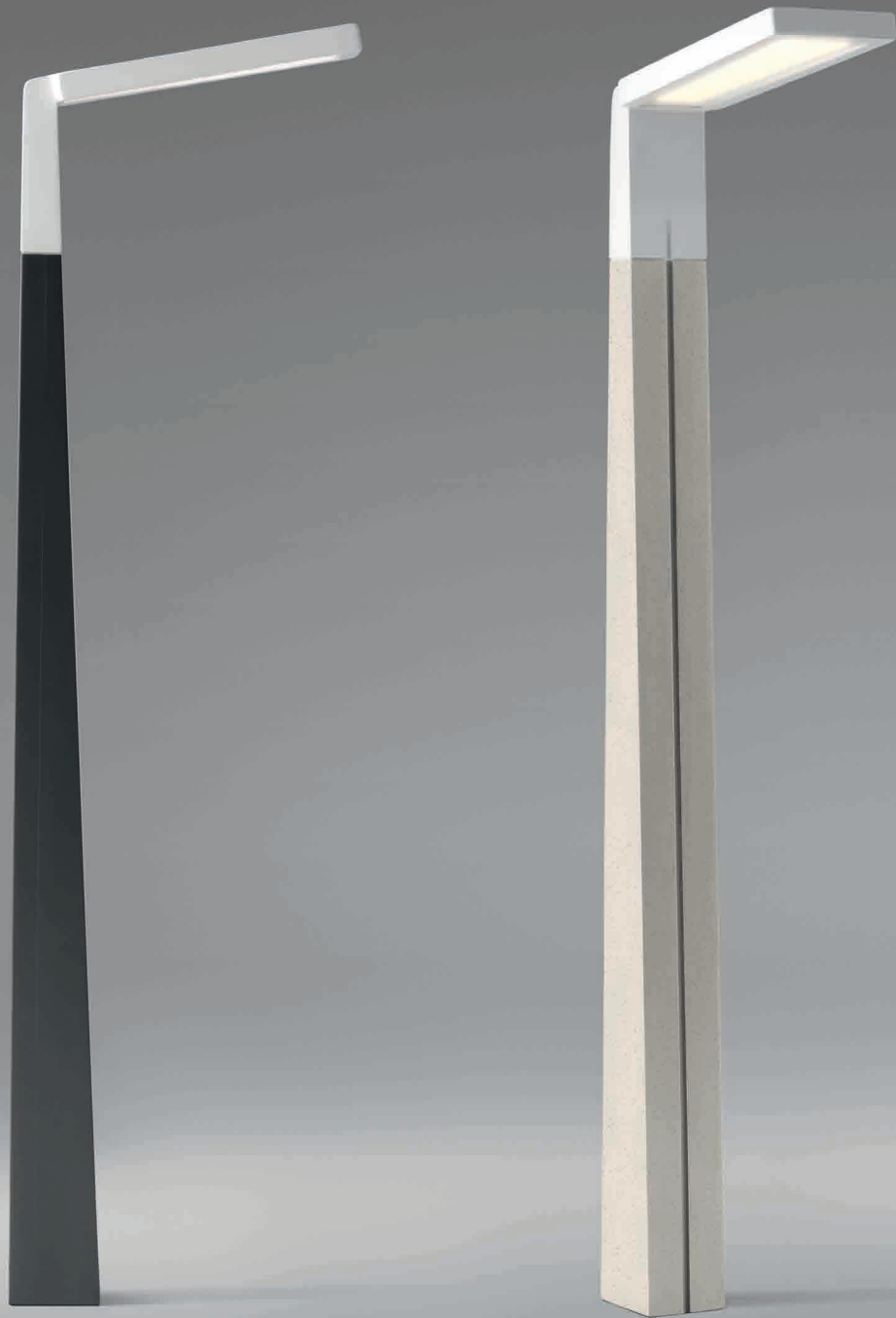



**1834**

Lampada outdoor da terra con struttura in cemento grigio chiaro o grafite. Diffusore in corian bianco. Disponibile in due dimensioni e due varianti: con alimentazione di rete o con pannello solare per autoricarica. Protezione IP65.

Outdoor floor lamp with structure in light grey or graphite concrete. Diffuser in white corian. Available in two sizes and two variants: with cable power supply or with solar panel for self-charging. IP65 protection.

**MATERIALE STELO / STEM MATERIAL**

 **Cemento grafite**  
Graphite concrete

 **Cemento grigio chiaro**  
Light grey concrete

**MATERIALE TESTA / HEAD MATERIAL**

 **Corian bianco**  
White corian

**SORGENTE / SOURCE** 

**1834-1X**  
3W LED 3000 K - 400 lm

**1834-1Y**  
8W LED 3000 K - 1100 lm

**1834-1Z**  
3W LED 3000 K - 400 lm

**1834-1W**  
8W LED 3000 K - 1100 lm

**TERRA / FLOOR**

**1834-1X**  
large solar



**1834-1Y**  
large



**1834-1Z**  
small solar

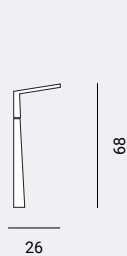

**1834-1W**  
small

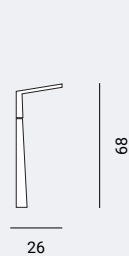

UMBERTO ASNAGO 2019

# L I T

*Light Inside a Tube*

Un oggetto mutevole che cambia con la luce. Spenta, Lit sembra una scultura sospesa, un tubo essenziale reso prezioso dai riflessi che si riverberano sul vetro. Accesa, la lampada rivela un'anima luminosa, calda e gentile.

A mutable object that changes with the light. When off, Lit looks like a suspended sculpture, a minimal tube made precious by the reflections that play on the glass. When lit, the lamp reveals a bright, warm and gentle soul.

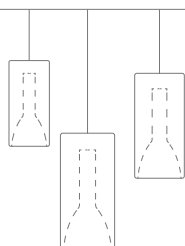













*A mutable object —  
that changes with the light.*





SPENTA / OFF



ACCESA / ON





## 1912

Lampade con struttura in metallo cromato lucido e vetro borosilicato.  
Diffusore esterno: viola, blu, oro e arancio. Diffusore interno rigato sabbato. Rosone a soffitto in titanio e bianco.

Suspensions with metal structure and shade in borosilicate glass.  
Outer shade in the colors: blue, violet, orange and gold. Inner shade in striped sandblasted glass. Ceiling canopy in white or titanium varnished metal.

## DIFFUSORE / OUTER SHADE

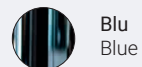

Blu  
Blue



Arancio  
Orange



Viola  
Violet



Oro  
Gold

## SORGENTE / SOURCE

**1912-23**  
1 x 10W LED E27

**1912-22**  
1 x 10W LED E27

**1912-21**  
1 x 5W LED E14

## SOSPENSIONE / SUSPENSION

**1912-23**  
large

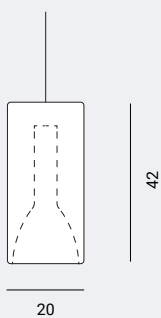

**1912-22**  
medium

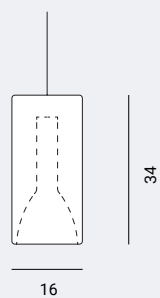

**1912-21**  
small

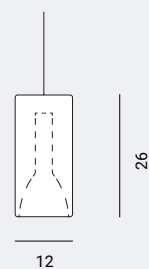

**Rosone**  
Canopy

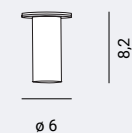

**Piastre a pag. 364**  
plates p. 364







UMBERTO ASNAGO 2015

# LULA

*A precious — accessory*

Un sottile stelo metallico sorregge un corpo illuminante  
in vetro dalle linee morbide e femminili.  
Nasce così Lula, lampada da tavolo e da terra che decora  
lo spazio con eleganza.

A thin metal stem supports a glass lighting body  
with soft, feminine lines.

Here is Lula, table or floor lamp that elegantly  
decorates the space.

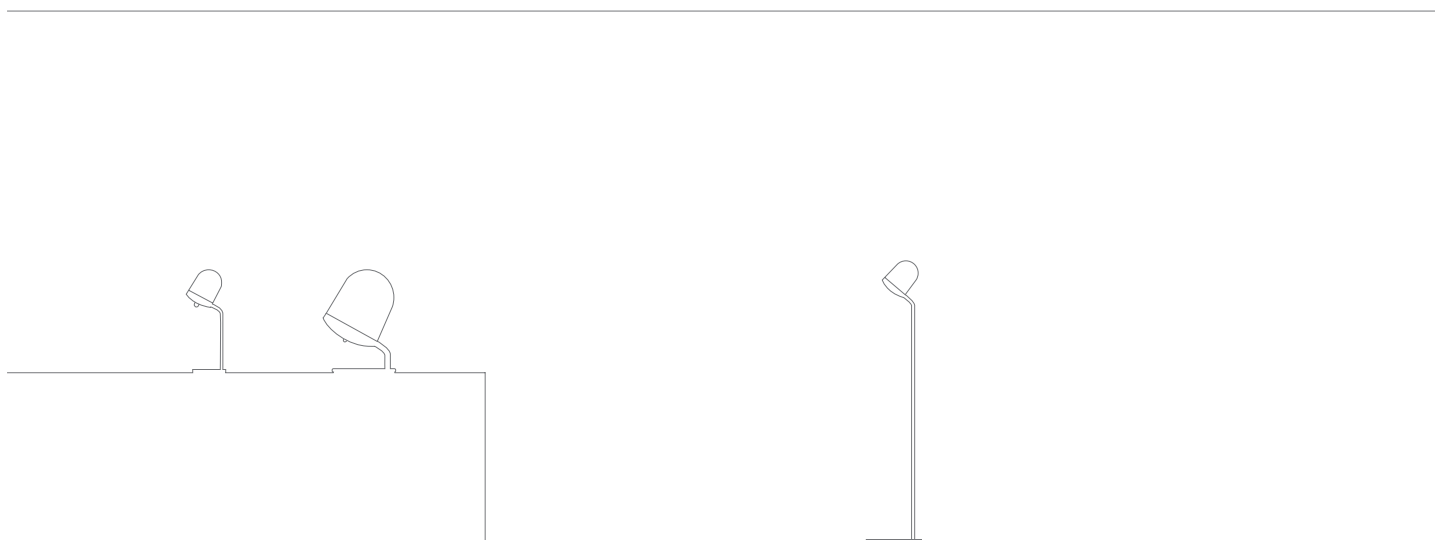



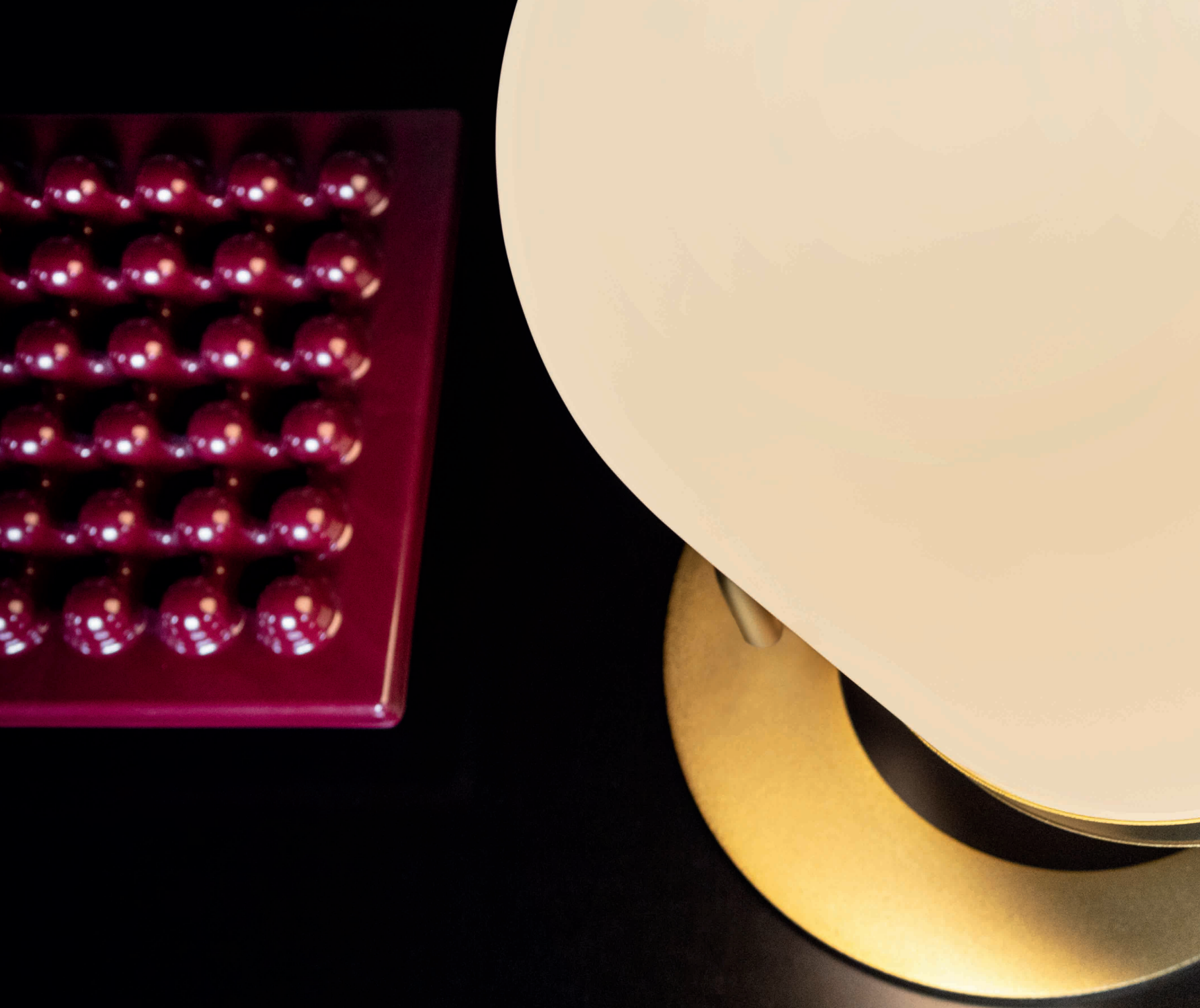

*A glass lighting body  
with soft — feminine lines*





















# LULA *Umberto Asnago, 2015*

## 1505

Lampade con struttura in metallo nelle finiture verniciate opache oro, oro rosa e grafite. Diffusore in vetro soffiato bianco.

Lamps with matt varnished metal structure in the colours: gold, rose gold and graphite. Shade in blown white glass.

## STRUTTURA METALLO / METAL STRUCTURE

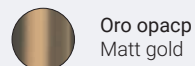

Oro opaco  
Matt gold

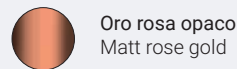

Oro rosa opaco  
Matt rose gold

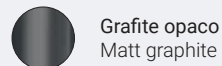

Grafite opaco  
Matt graphite

## VETRO LUCIDO / GLOSSY GLASS

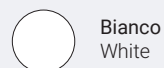

Bianco  
White

## SORGENTE / SOURCE

**1502-03**  
1 x 10W LED E27 

**1502-02**  
1 x 5W LED E14

**1502-10**  
1 x 5W LED E14 

## TERRA / FLOOR

### 1505-10

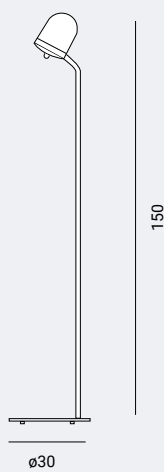

## TAVOLO / TABLE

### 1505-03

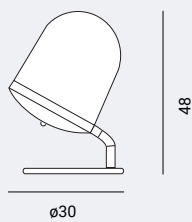

ø30

### 1505-02

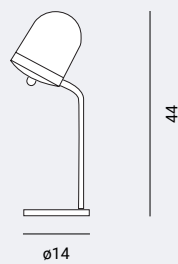

ø14

UMBERTO ASNAGO 2015

# MAMI

*An eclectic — piece of art*

Tra design e arte, Mami è una collezione dall'eleganza versatile. Merito del modulo ovale in vetro soffiato bianco, reinterpretato in chiave modernista nelle configurazioni sospese e più lineare nelle varianti da tavolo, da terra e applique.

Halfway between design and art, Mami is a versatile and elegant collection. The white oval blown-glass body is reinterpreted with a modernist look in the suspension compositions, while remaining linear in the floor, table and wall variants.

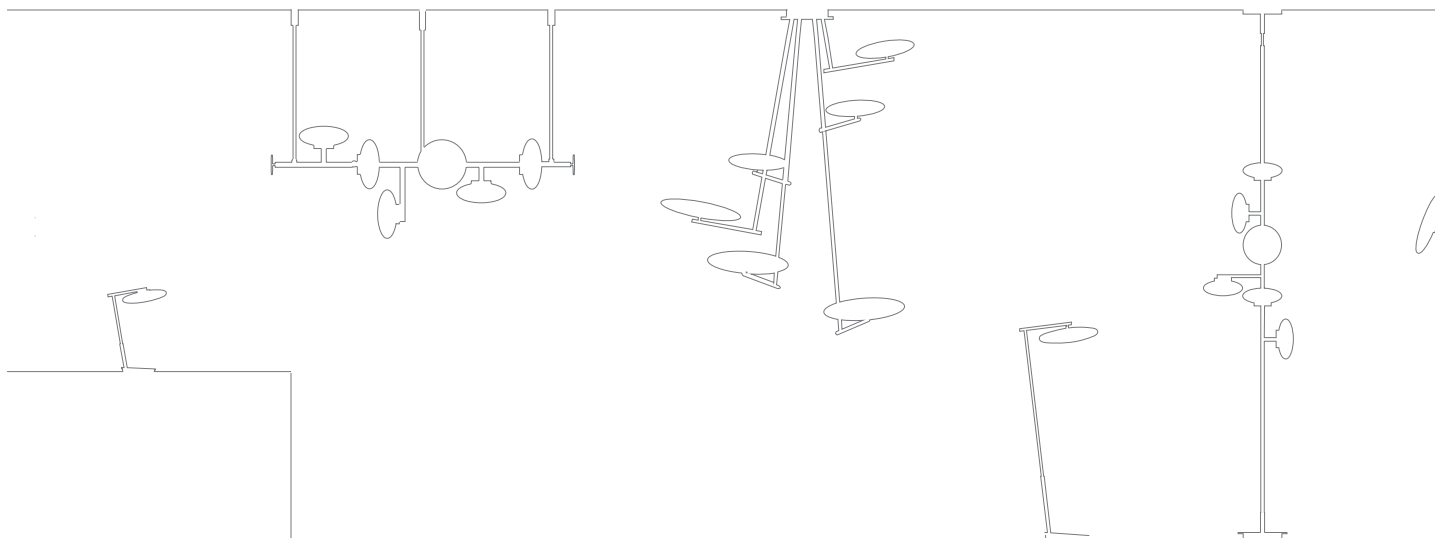

















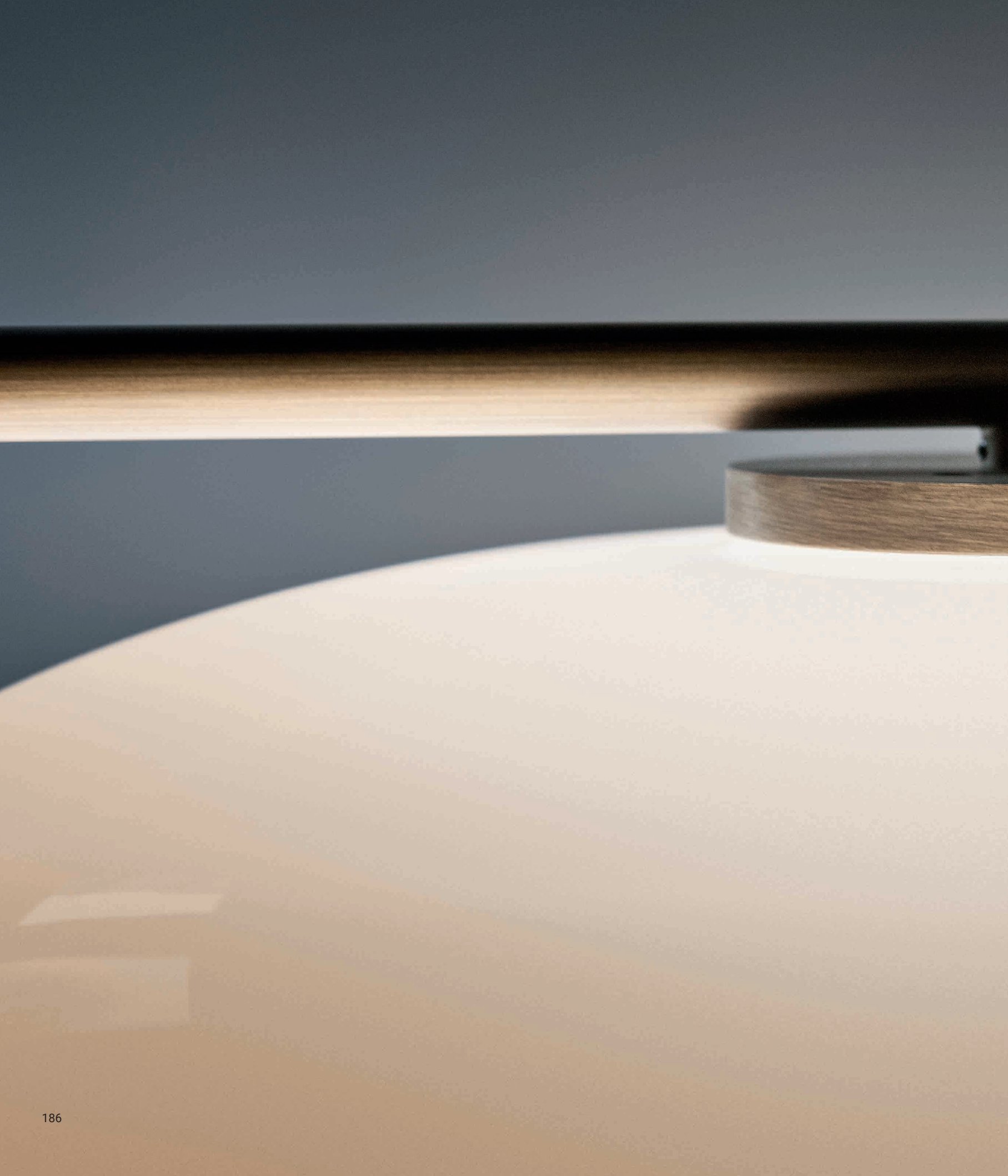

*An elegant collection  
halfway between  
—design and art*























Mami orizzontale  
Mami orizzontal



Mami verticale  
Mami vertical





















# MAMÌ *Umberto Asnago, 2015*

## 1307

Lampade con struttura in metallo verniciato grafite o bronzo.  
Diffusore in vetro soffiato bianco.

Lamps with structure in graphite varnished metal or bronze.  
Shade in white blown glass.

## STRUTURA METALLO / METAL STRUCTURE



Bronzo  
Bronze



Grafite  
Graphite

## VETRO LUCIDO / GLOSSY GLASS



Bianco  
White

## TAVOLO / TABLE

### 1307-03

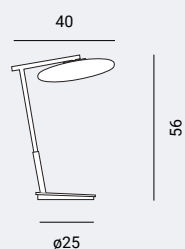

## TERRA-CIELO / FLOOR-CEILING

### 1307-12 large

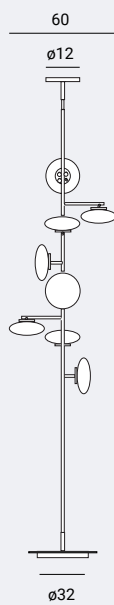

### 1307-11 small

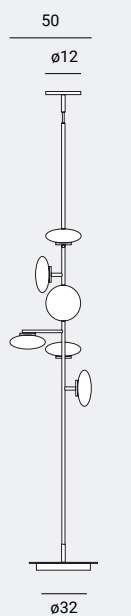

## TERRA / FLOOR

### 1307-10

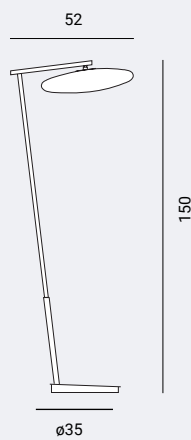

min. 300 - max 270

min. 250 - max 280

## APPLIQUE / WALL

### 1307-33 large



### 1307-32 medium



### 1307-31 small



### 1307-43

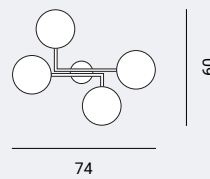

**SOSPENSIONI / SUSPENSION**

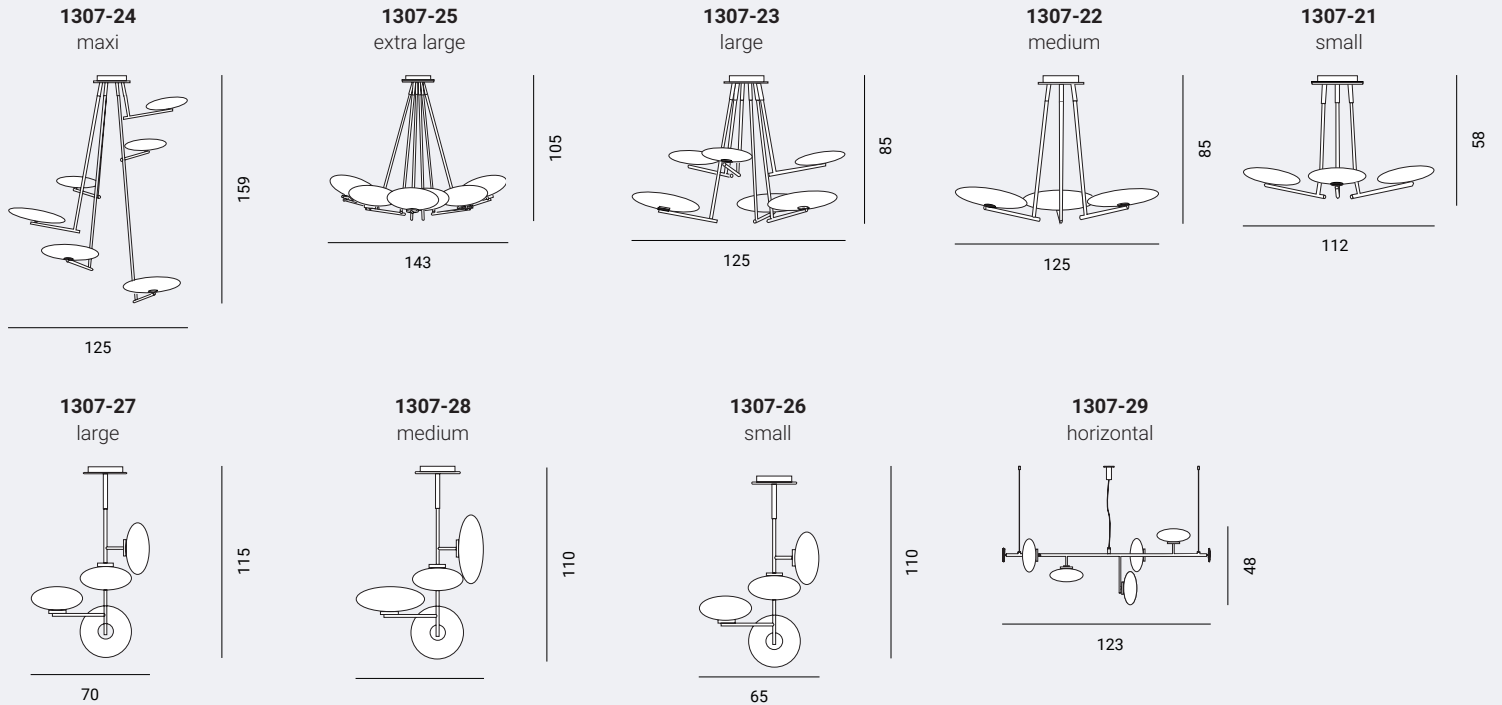

**PLAFONIERE / CEILING LAMP**

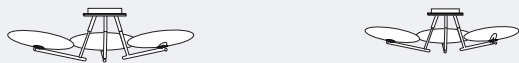

**SORGENTE/ SOURCE** (LED)

**1307-03**  
10W LED 3000 K

**1307-10**  
10W LED 3000 K

**1307-12**  
8 x 6W LED 3000 K 

**1307-11**  
6 x 6W LED 3000 K 

**1307-33**  
10W LED 3000 K

**1307-32**  
10W LED 3000 K

**1307-31**  
6W LED 3000 K

**1307-43**  
4 x 6W LED 3000 K

**1307-24**  
6 x 10W LED 3000 K

**1307-25**  
6 x 10W LED 3000 K

**1307-23**  
6 x 10W LED 3000 K

**1307-22**  
3 x 10W LED 3000 K

**1307-21**  
3 x 10W LED 3000 K

**1307-27**  
4 x 10W LED 3000 K

**1307-28**  
2x 10W LED 3000 K + 2 x 6 W LED 3000 K

**1307-26**  
4 x 6W LED 3000 K

**1307-29**  
5 x 6W LED 3000 K

**1307-42**  
3 x 10W LED 3000 K

**1307-41**  
3 x 10W LED 3000 K

# M O M

*Venetian heritage — for today*

Sono ispirate alla tradizione veneziana le lampade Mom, che nella forma e nelle finiture opache si rifanno ai classici vasi in vetro di Murano. Disponibili anche nelle varianti da tavolo e applique, in versione lucida sono simili a pietre preziose.

Mom lamps are inspired by the Venetian tradition, and refer, in the shape and opaque finishings, to the classical Murano glass vases. Also available in table and wall variants, in the glossy variants they look like precious stones.

















*Inspired by —  
the Venetian tradition*







Verde salvia  
Sage green

Rosa cipria  
Powder pink

Senape  
Mustard

Sabbia  
Sand

Blu avio  
Blue avio





Nero  
Black

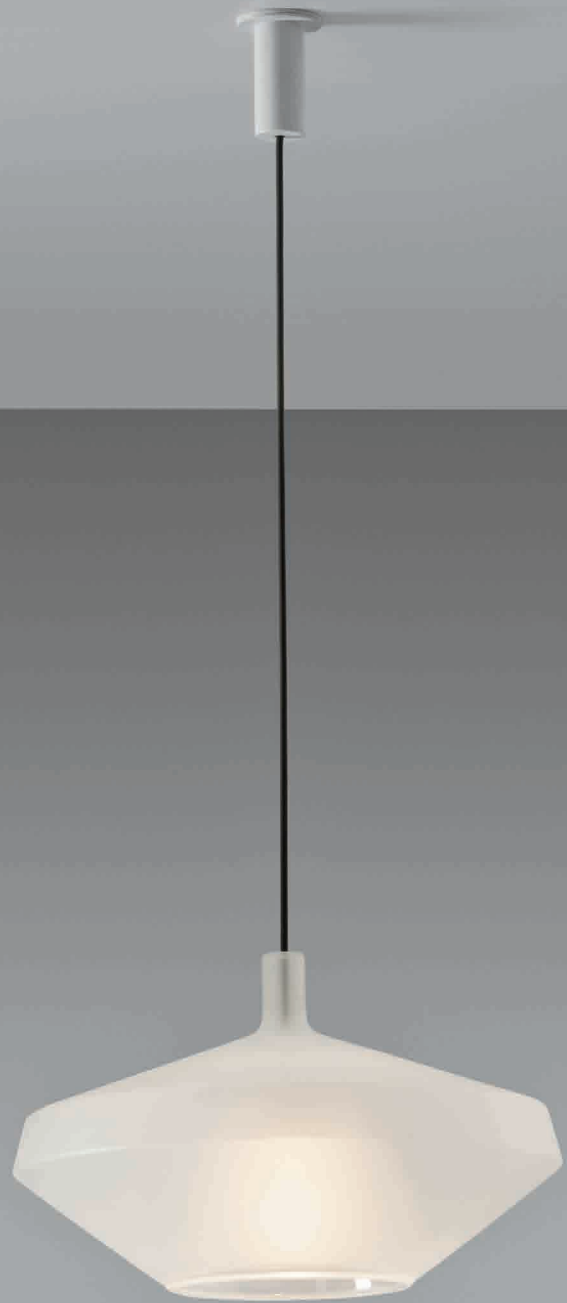

Bianco  
White

Colori opachi  
Matt colors







Viola lucido  
Glossy violet



SPENTA / OFF

Blu lucido  
Glossy blue



Verde lucido  
Glossy green



ACCESA / ON



























# MOM *Umberto Asnago, 2016*

## 1602

Collezione di lampade in cinque forme realizzate in vetro borosilicato  
 Finitura opaca: senape, blu avio, verde salvia, rosa cipria, sabbia,  
 bianco e nero. Finitura lucida: blu, verde, viola. Lampade da tavolo con  
 struttura in metallo nei colori opachi oro, oro rosa e grafite. Appliques  
 con struttura in metallo nei colori opachi oro, oro rosa, grafite e bianco.  
 Rosone a soffitto bianco o titanio.

Collection of lamps in five shapes made in borosilicate glass: Mat  
 finishes: blue avio, sage green, powder pink, sand, white. Glossy finishes:  
 green, blue, violet. Table lamps with metal structure in the colors gold,  
 rose gold and graphite. Wall lamps in the colors gold, rose gold, graphite  
 and white. Canopy in white or titanium varnished metal.

### SOSPENSIONE / SUSPENSION

**1602-21**  
low

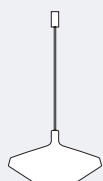

**1602-22**  
tall



**1602-23**  
slim



**1602-24**  
fatty

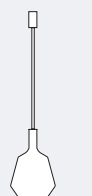

**1602-25**  
little



**Rosone**  
Canopy

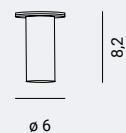

**Piastre a pag. 364**  
plates p. 364

### TAVOLO / TABLE

**1602-01**  
low

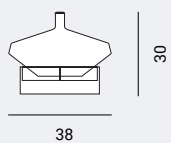

**1602-02**  
tall

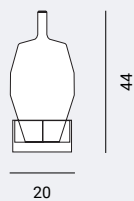

**1602-04**  
fatty

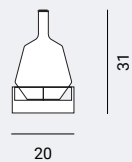

**1602-05**  
little

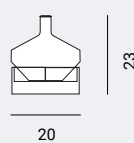

### APPLIQUE / WALL

**1602-34**  
fatty

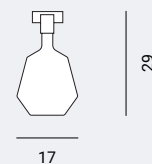

**1602-33**  
slim



**VETRI FINITURE OPACHE / MATT GLASSES FINISHES**



**VETRI FINITURE LUCIDE / GLOSSY GLASSES FINISHES**

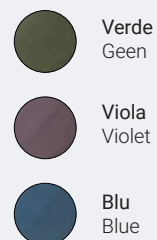

**STRUTTURA TAVOLO / TABLE STRUCTURE**



**STRUTTURA APPLIQUE / WALL STRUCTURE**

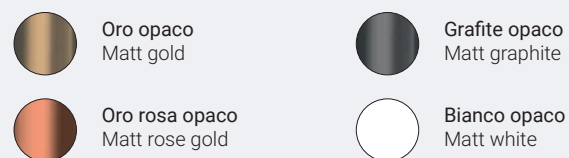

**SORGENTE/ SOURCE** 

**1602-21**  
1 x 10W LED E27

**1602-22**  
1 x 10W LED E27

**1602-23**  
1 x 10W LED E27

**1602-24**  
1 x 5W LED E14

**1602-25**  
1 x 5W LED E14

**1602-01**  
1 x 10W LED E27

**1602-02**  
1 x 10W LED E27

**1602-04**  
1 x 5W LED E14

**1602-05**  
1 x 5W LED E14

**1602-33**  
1 x 5W LED E14

**1602-34**  
1 x 5W LED E14











NICOLA GALLIZIA 2017

# NARCISO

*Inspired by — an eternal myth*

Come nel mito classico Narciso guarda la sua immagine riflessa nell'acqua, così il cono dell'omonima lampada si sdoppia per diffondere e riflettere la luce delicata del corpo illuminante. Omaggio alla musica la versione da tavolo, con diffusore audio bluetooth.

As in the classic myth Narciso looks at his image reflected in the water, likewise the cone of this lamp splits up to spread and reflect the delicate light of the lighting body. The table version is a tribute to music, complete with bluetooth audio speakers.

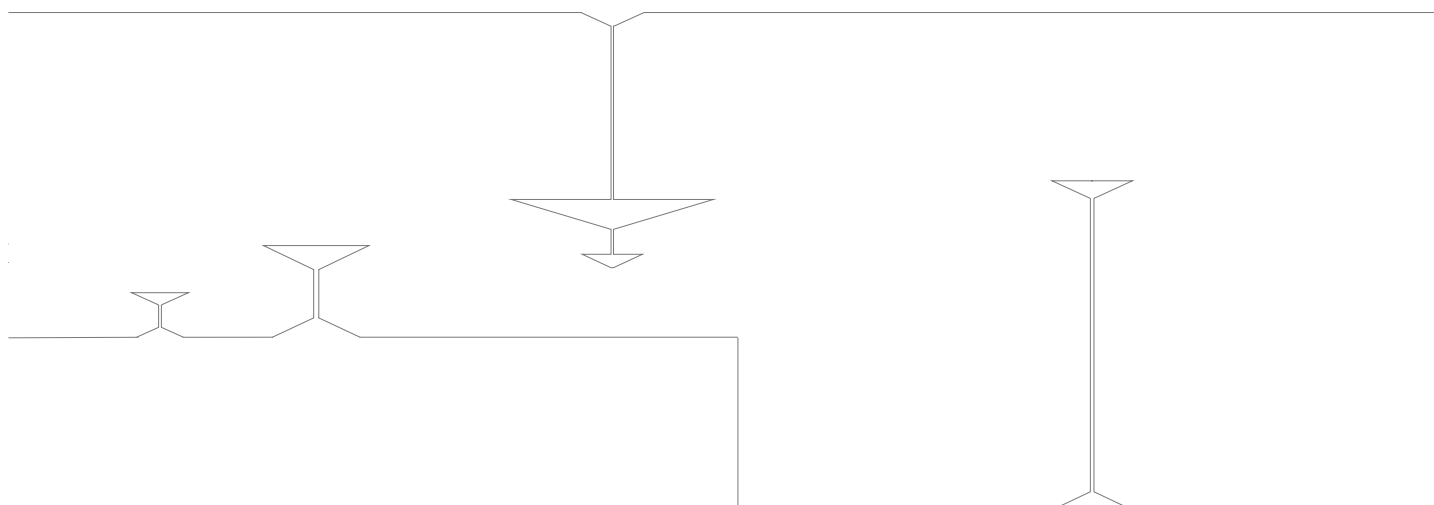













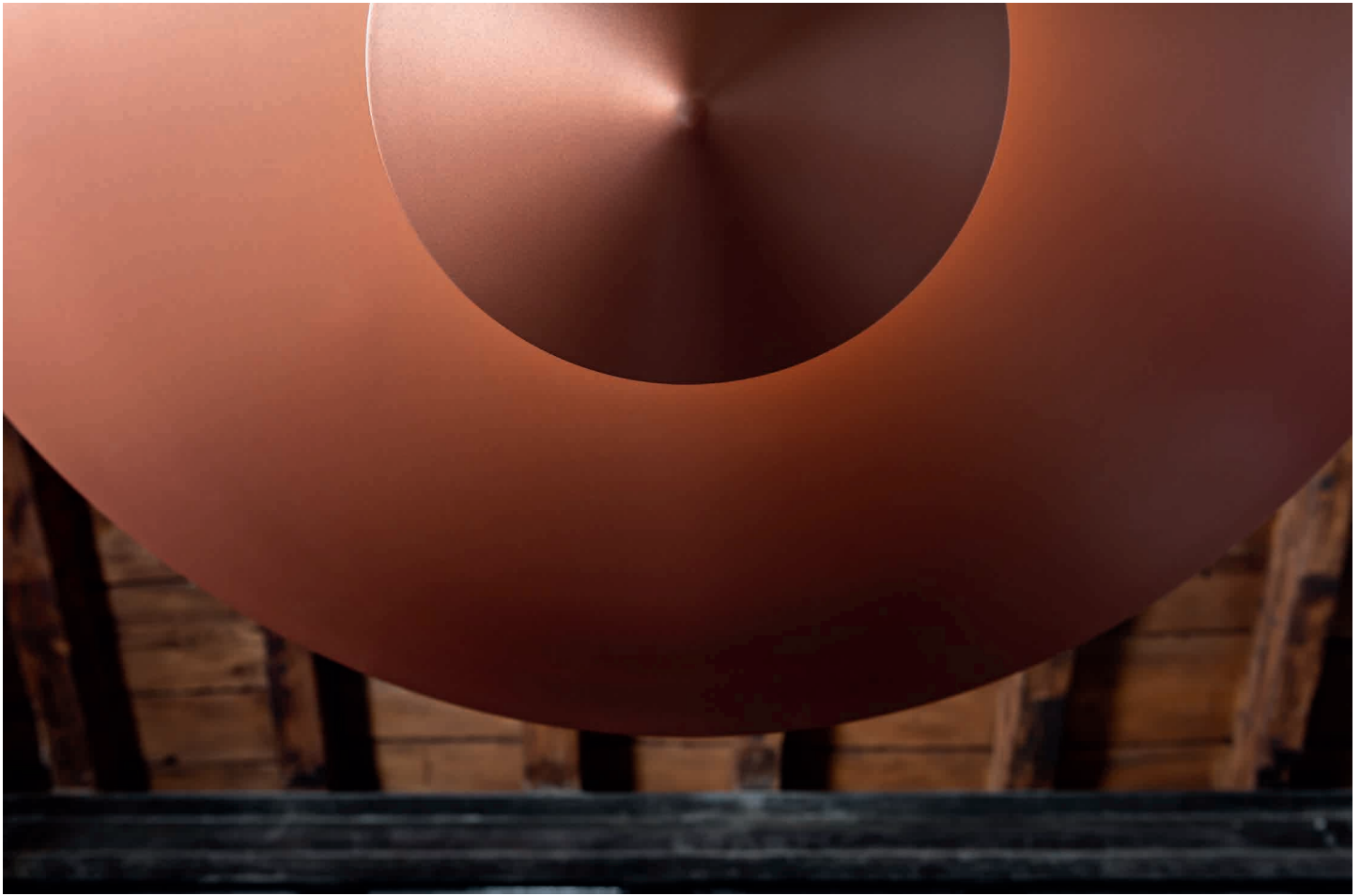











*Splitting up to spread —  
and reflect the delicate light*

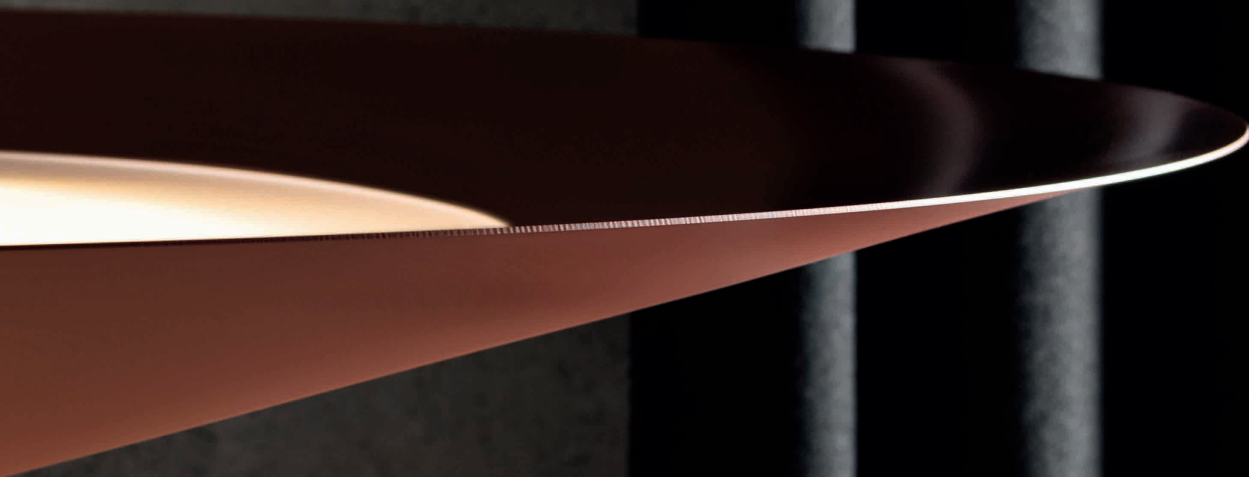

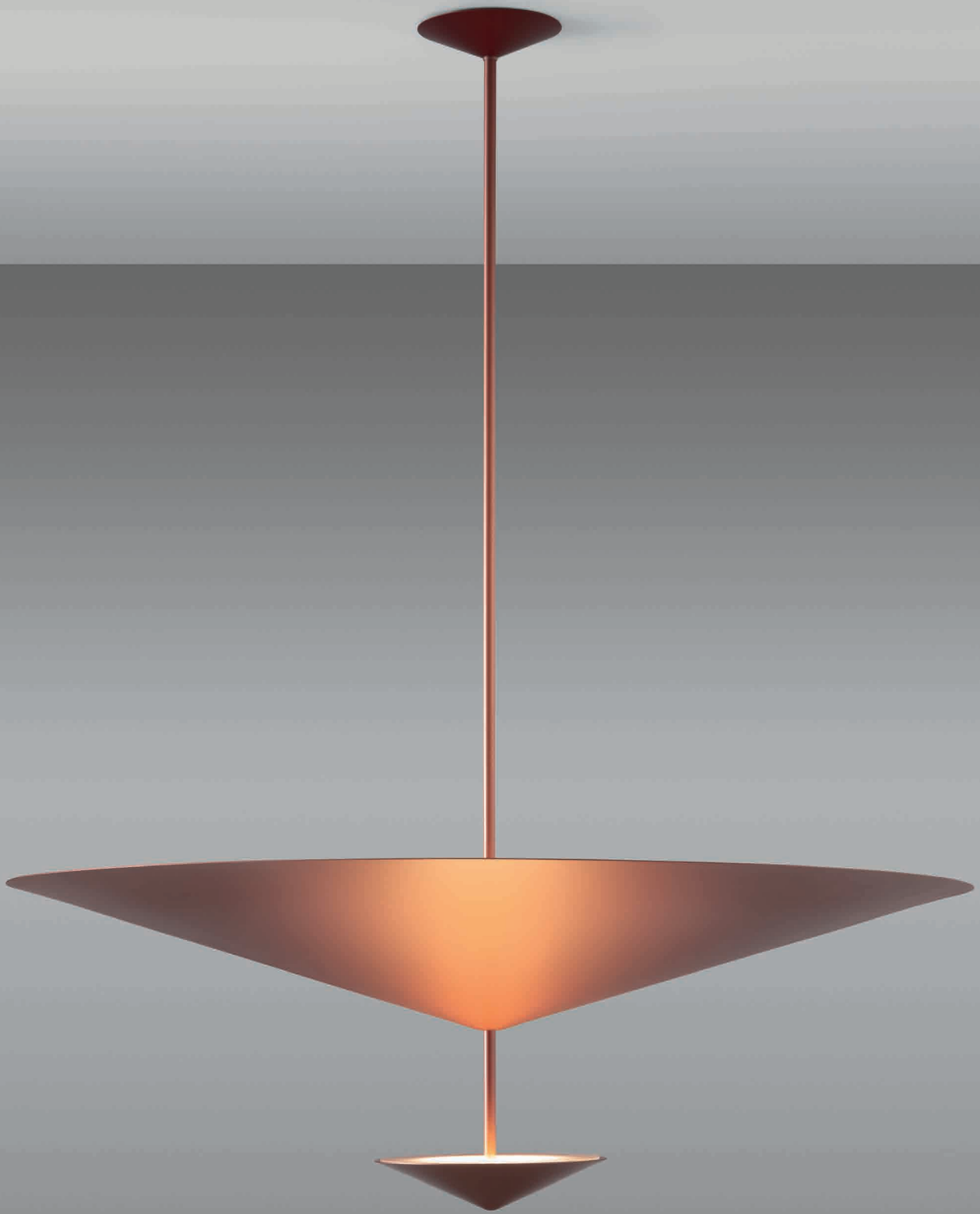



























# NARCISO *Nicola Gallizia, 2017*

## 1710

Lampade con struttura in metallo nelle finiture: oro opaco, oro rosa opaco, grafite opaco e verniciato bianco. La lampada da tavolo piccola è portatile, dotata di batteria ricaricabile. La lampada da tavolo grande è disponibile nella versione portatile/ricaricabile con diffusore audio bluetooth. A richiesta: sospensione dimmerabile. Disponibile anche nella versione outdoor con protezione IP44.

Lamps with metal structure in the finishes: mat gold, mat pink gold, mat graphite and white varnished. The small table lamp is portable, with rechargeable battery. The large table lamp is available in the portable/ rechargeable version with Bluetooth audio speaker. On demand: dimmable pendant. Available also as outdoor version with protection IP44.

## STRUTTURA METALLO / METAL STRUCTURE



Oro opaco  
Matt gold



Grafite opaco  
Matt graphite



Oro rosa opaco  
Matt rose gold



Bianco opaco  
Matt white

## SORGENTE / SOURCE

**1710-03**  
14W LED 3000 K - 1500 lm

**1710-10**  
4,5W LED 3000 K - 450 lm

**1710-04**  
8W LED 3000 K - 1000 lm 

**1710-15**  
14W LED 3000 K - 1500 lm

**1710-01**  
4,5W LED 3000 K - 450 lm 

**1710-20**  
14W LED 3000 K - 2600 lm  
+  
45W LED 3000 K - 6000 lm

## TAVOLO / TABLE

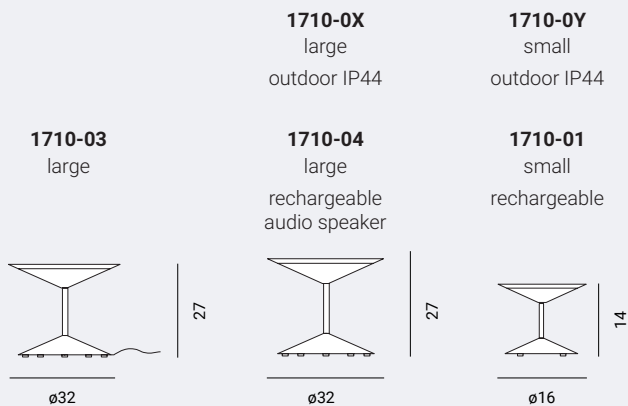

## SOSPENSIONE / SUSPENSION

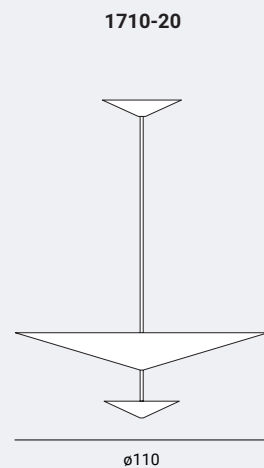

## TERRA / FLOOR

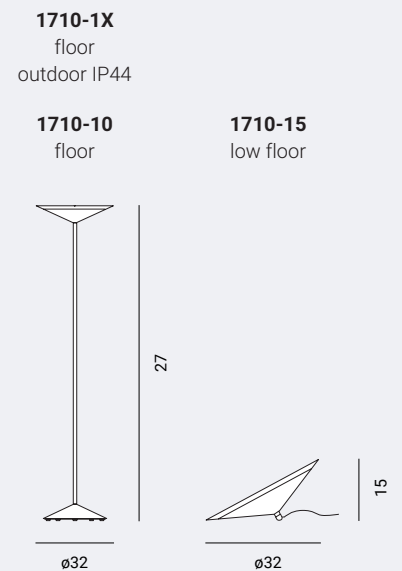

UMBERTO ASNAGO 2011

# P O L A R

*An iceberg of — warm light*

Polar è un volume puro di vetro soffiato opalino che diffonde un chiarore caldo e morbido. Un totem di luce che rende subito accogliente qualsiasi spazio.

Polar is a pure volume of opal blown glass which spreads a warm and soft glow. A light totem, designed to immediately put warmth in any place.

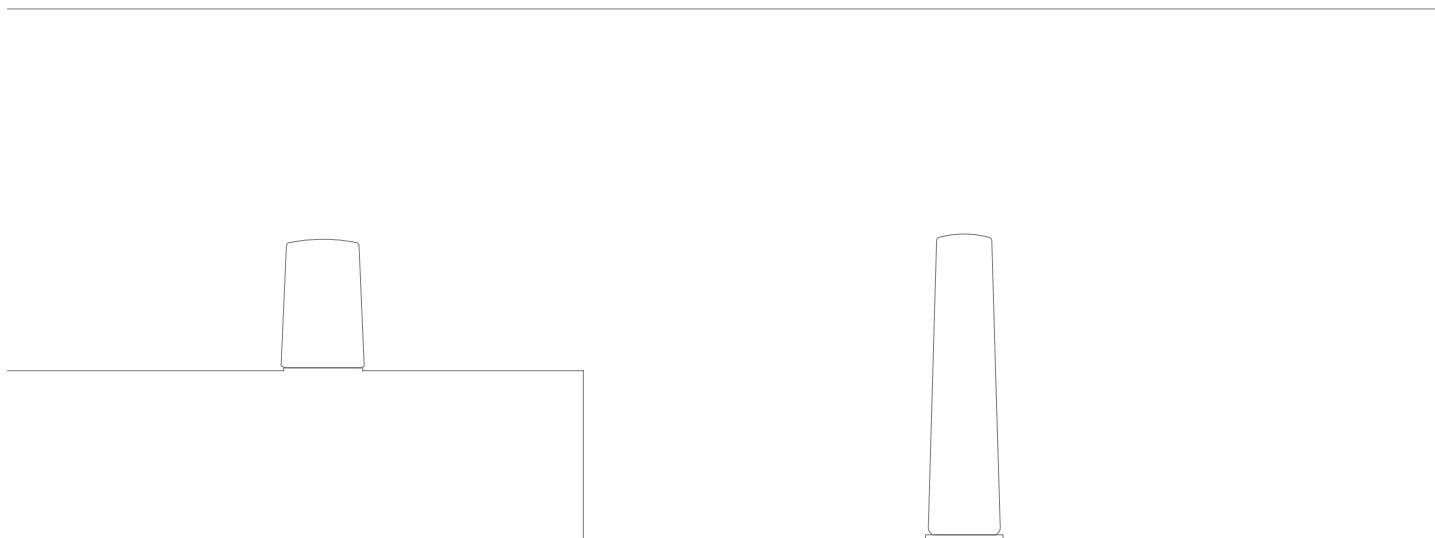





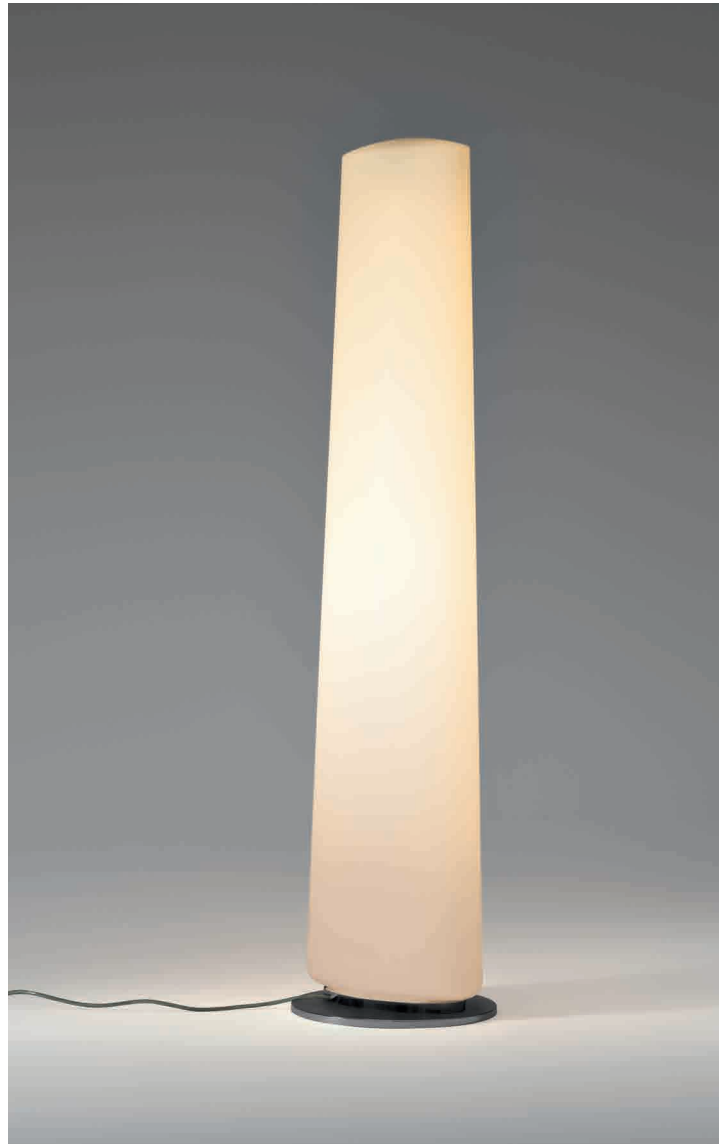







# POLAR *Umberto Asnago, 2011*

## 1106

Lampade da terra e tavolo con struttura in metallo verniciato grafite.  
Diffusore in vetro soffiato opalino bianco.

Floor and table lamps with structure in graphite varnished metal.  
Shade in white opal blown glass.

## STRUTTURA METALLO / METAL STRUCTURE

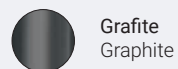

## FINITURA DIFFUSORE / SHADE FINISHES

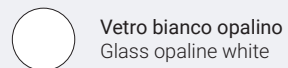

## SORGENTE / SOURCE

**1106-03**  
28,8W LED 2700 K



**110610**  
58W LED 2700 K



## TERRA / FLOOR

### 1106-10

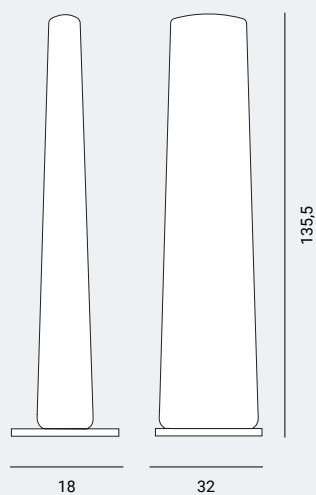

## TAVOLO / TABLE

### 1106-03

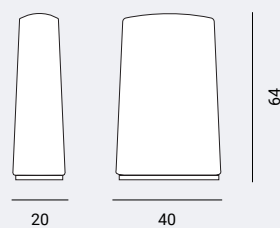

UMBERTO ASNAGO 2017

# POP

*Light vs. shade*

Una lampada dalle forme giocose, un oggetto indisciplinato che mescola ironia ed eleganza: Pop è un applique sferica che dipinge sulla parete luci e ombre inattese.

A playful lamp, an unruly object that mixes irony and elegance: Pop is a spherical wall light that paints unexpected lights and shadows on the wall.





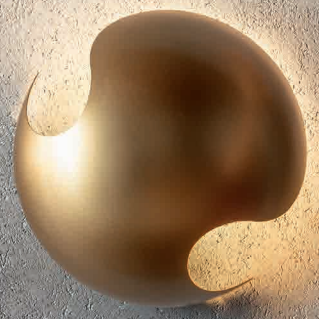
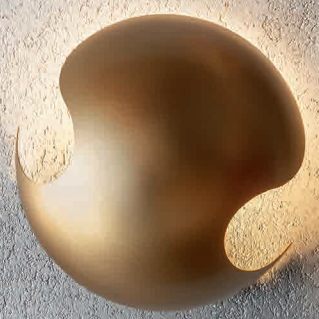



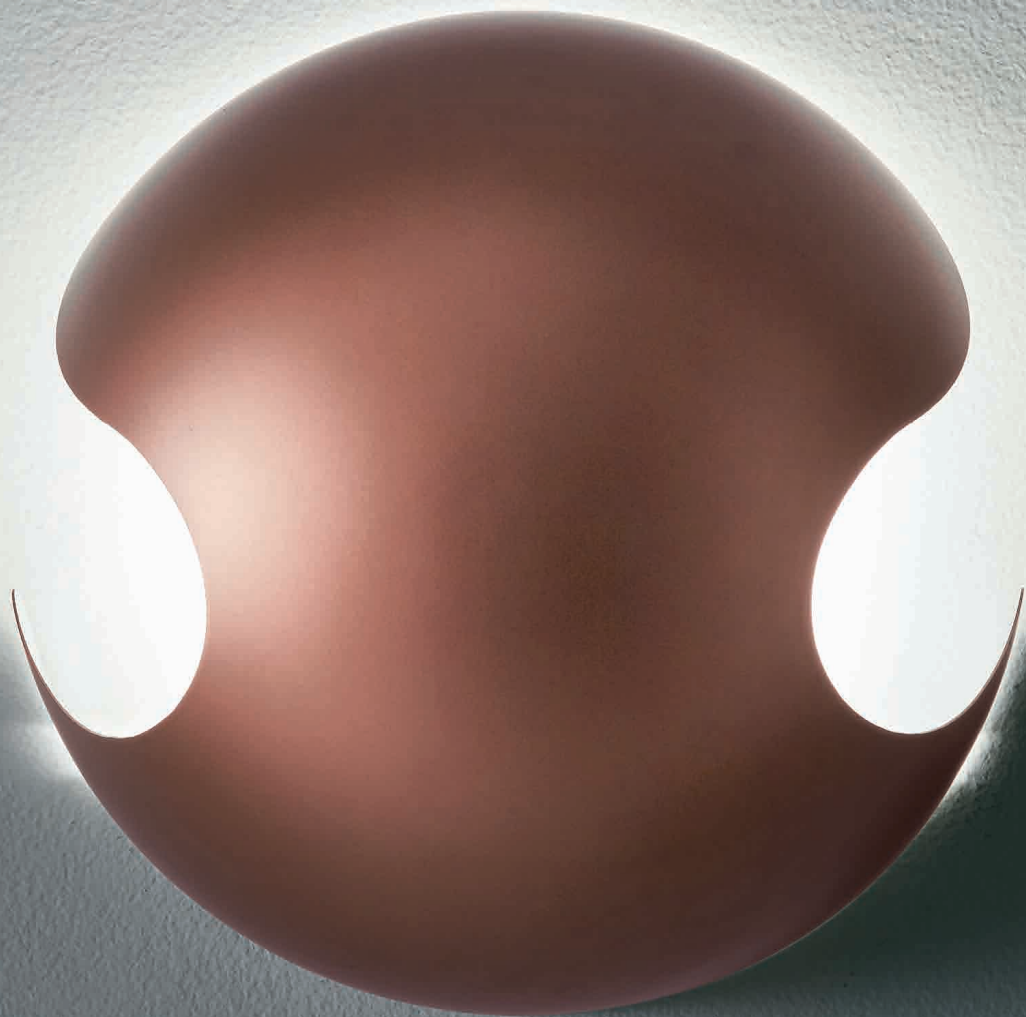







*A playful lamp —  
an unruly object*



# POP *Umberto Asnago, 2017*

## 1705

Applique orientabile nelle finiture lucide o opache: oro, oro rosa, grafite, sabbia e bianco.

Adjustable wall lamp in the glossy or matt finishes: gold, rose gold, graphite, sand and white.

## FINITURE LUCIDE O OPACHE / GLOSSY OR MAT FINISHES

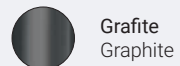
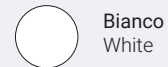
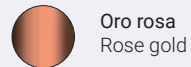

## SORGENTE / SOURCE

**1705-30**  
10W LED 3000 K - 1300 lm  
Dimmable Triac

## APPLIQUE / WALL

### 1705-30

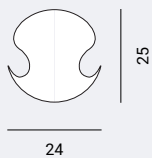

UMBERTO ASNAGO 2017

# S P O O N

*Beauty — matches function*

L'estrema pulizia della forma incontra la ricchezza della pelle intrecciata nella collezione Spoon, un piccolo capolavoro di bellezza e funzionalità, con stelo e calotta da orientare a piacere.

An extreme neat shape meets the rich hand woven leather in Spoon collection, a small masterpiece of beauty and functionality, with swiveling stem and shell.











*A small masterpiece  
— of beauty  
and functionality*





















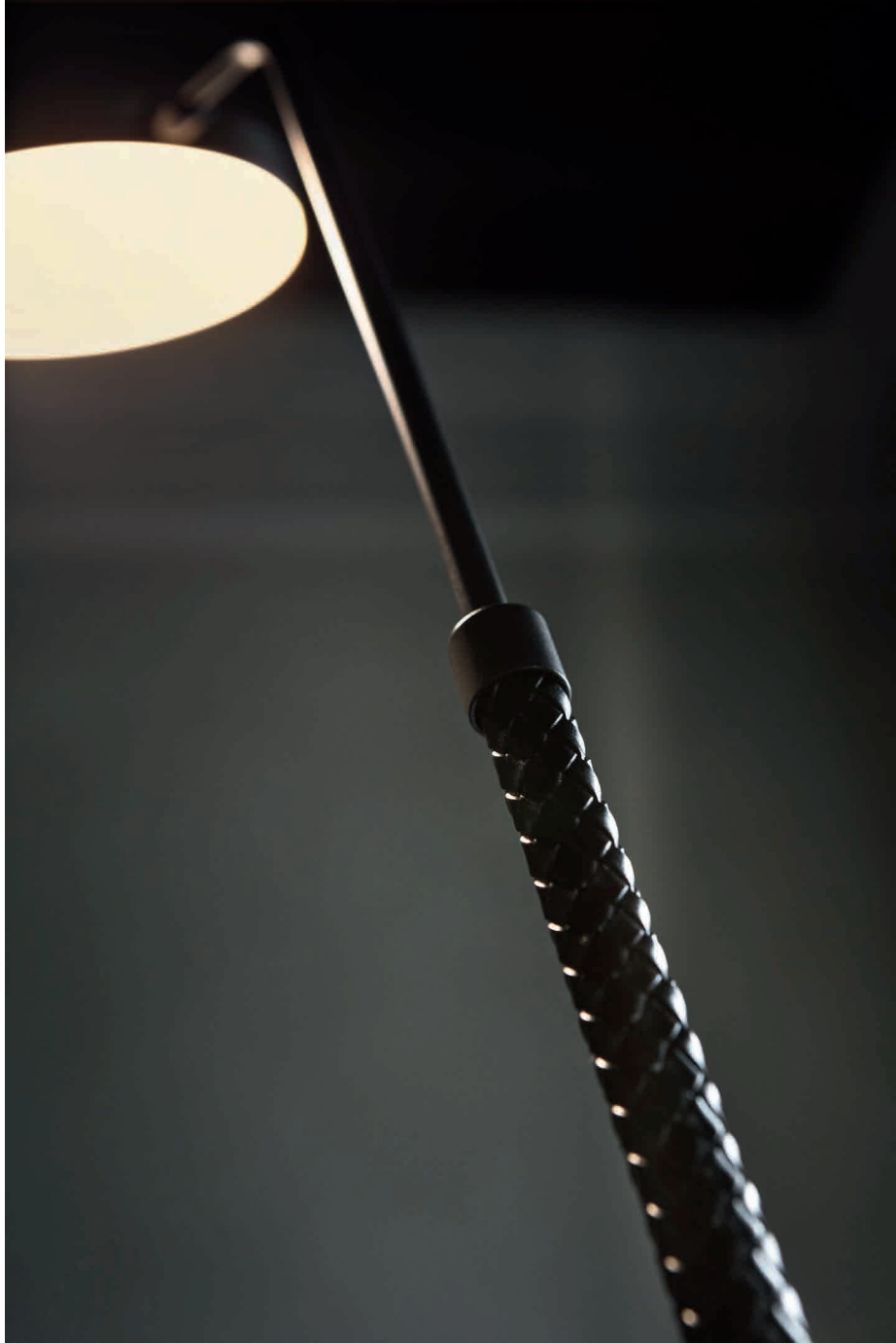









# SPOON *Umberto Asnago, 2017*

## 1706

Lampade con struttura in metallo opaco e pelle intrecciata a mano nei seguenti abbinamenti: oro rosa opaco / pelle cognac e grafite opaco / pelle nera. Rosone singolo nelle stesse finiture della struttura. Utilizzabile come elemento singolo o multiplo.

Lamps with structure in mat metal and hand-woven leather in the following matchings: matt pink gold / cognac leather and matt graphite / black leather. Single canopy in the same finishes of the structure. Available as single element or in cluster.

## FINITURE / FINISHES



Oro rosa opaco  
Matt rose gold



Pelle cognac  
Cognac leather



Grafite opaco  
Matt graphite



Pelle nera  
Black leather

## SORGENTE / SOURCE

### 1706-21

2x4W LED 3000 K - 2x600 lm

4W LED 3000 K - 600 lm

## TAVOLO / TABLE

1706-00

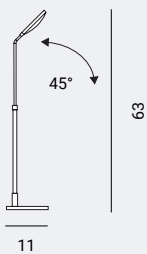

## TERRA / FLOOR

1706-10

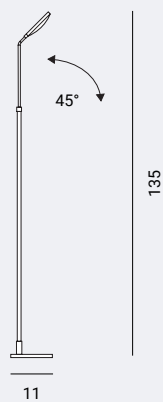

## SOSPENSIONE / SUSPENSION

1706-21

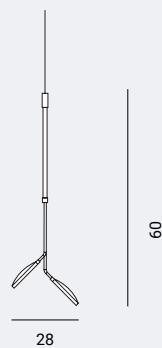

## APPLIQUE / WALL

1706-30

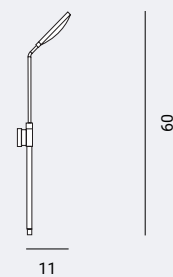



BARTOLI DESIGN 2017

# STORM

*Lights — that sparkle*

Steli sottili in preziose finiture metalliche creano suggestive armonie di luce. Disponibile in tre misure, Storm è una lampada che vive anche da sola ma è pensata per essere usata in gruppo, negli spazi del contract come in quelli di casa.

Thin stems in precious metallic finishes create evocative harmonies of light. Available in three sizes, Storm is a lamp that can live alone but is designed to be used in groups, in public spaces as well as at home.

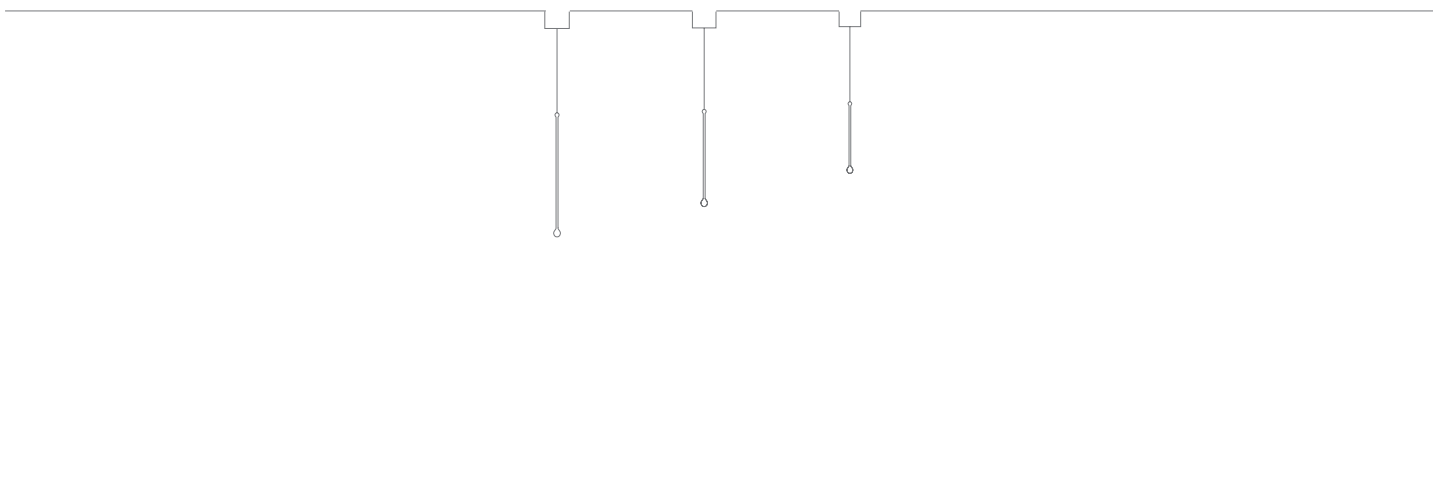







*Creating evocative  
— harmonies of light*













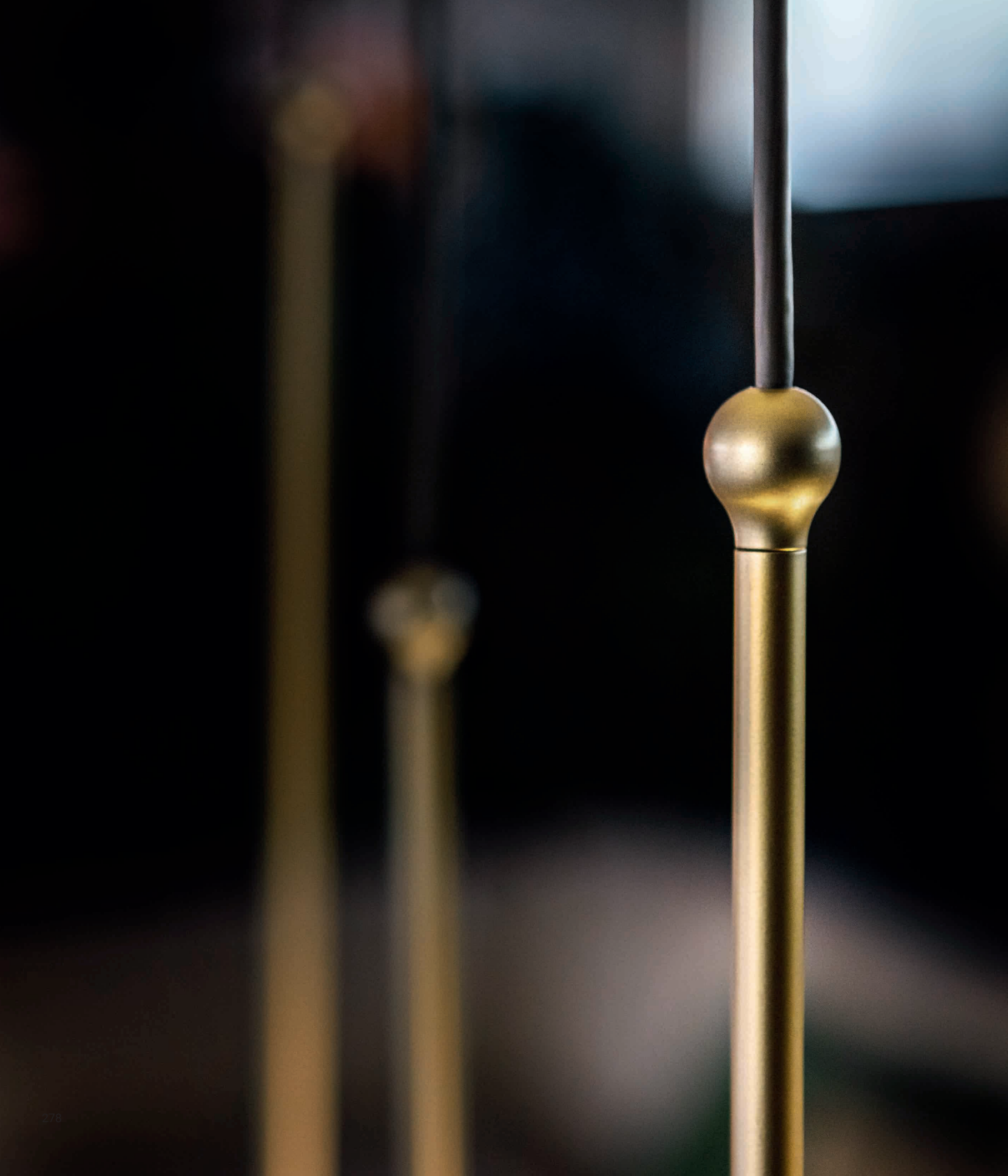

# STORM *Bartoli Design, 2017*

## 1704

Sospensione composta da un'asta in metallo nelle finiture opache: oro, oro rosa e grafite. Disponibile in tre dimensioni: Large, Medium e Mini, utilizzabile come elemento singolo o multiplo. Rosone singolo nelle stesse finiture della struttura.

Pendant lamp made by a metal stick in the mat finishes: gold, rose gold and graphite. Available in three sizes: Large, Medium and Mini as single element or in cluster. Single canopy in the same finishes of the structure.

## STRUTTURA METALLO / METAL STRUCTURE

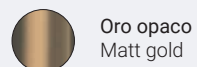

Oro opaco  
Matt gold

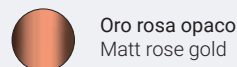

Oro rosa opaco  
Matt rose gold

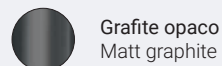

Grafite opaco  
Matt graphite

## SORGENTE/ SOURCE

4W LED 3000 K - 400 lm

## SOSPENSIONE / SUSPENSION

**1704-23**  
large



**1704-21**  
medium



**1704-20**  
mini

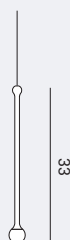

**Rosone**  
Canopy

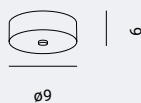

**Piastre a pag. 364**  
plates p. 364

UMBERTO ASNAGO, 2009

# T A A A C

*Flexible arch — flexible light*

Taaac rielabora in forma contemporanea il classico arco, con in più il tocco sartoriale dei dettagli in cuoio a impreziosire la struttura in materiale termoplastico. Protagonista è l'emissione luminosa, i cui parametri illuminotecnici si programmano con il telecomando.

Taaac reworks the classic arch in a contemporary form, with the tailoring touch of leather details to enrich the structure made of thermoplastic. The focus is on the light emission, whose parameters are programmed with the remote control.

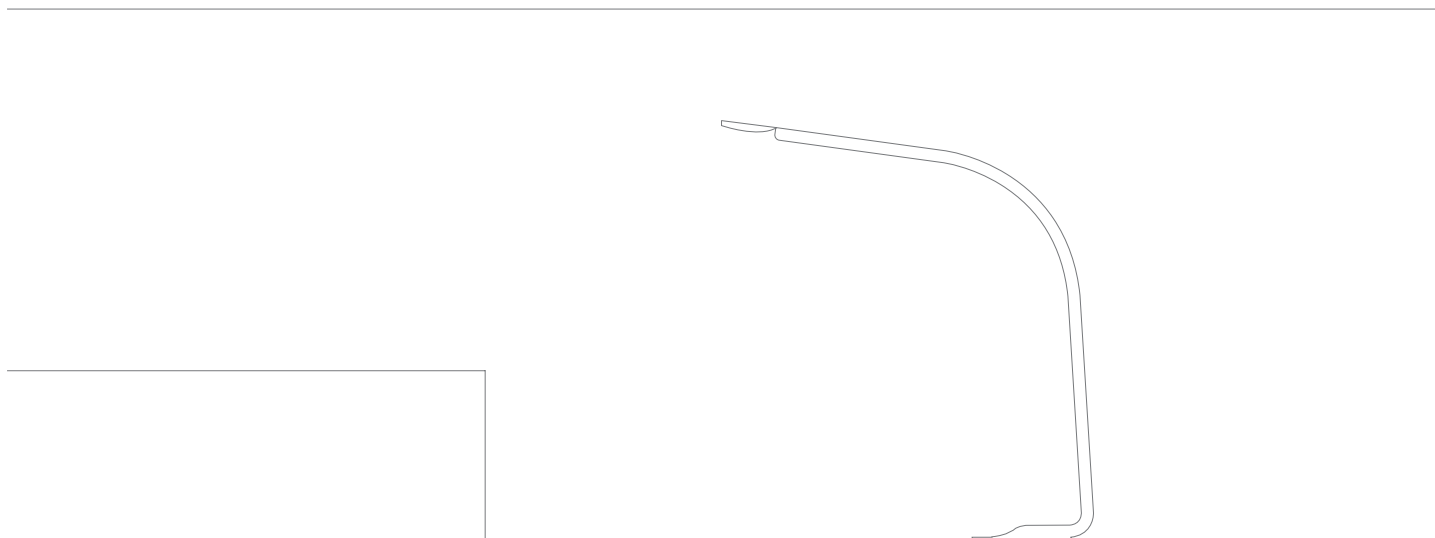

















# TAAAC *Umberto Asnago, 2009*

## 0808

Lampada da terra con base in metallo nero gofrato e struttura in espanso termoplastico lucido bianco o nero, o rivestita in cuoio nei colori: bianco, nero, testa di moro, tortora. Orientabile 360°. Luce LED superiore ed inferiore con accensione separata con telecomando.

Floor lamp with base in embossed black metal and structure in glossy thermoplastic expansion white or black, or covered with leather in the colors: white, black, testa di moro, tortora. 360° adjustable. Upper and lower separated LED lighting with remote control.

## ESPANSO TERMOPLASTICO / THERMOPLASTIC EXPANSION

 Bianco lucido  
Glossy white

 Nero lucido  
Glossy black

## CUOIO / LEATHER

 Bianco  
White

 Nero  
Black

 Testa di moro  
Testa di moro

 Tortora  
Tortora

## SORGENTE/ SOURCE

3W LED 3500 K - Direct  
+  
25W LED 2900/5000 K - Indirect

## TERRA / FLOOR

### 0808-10

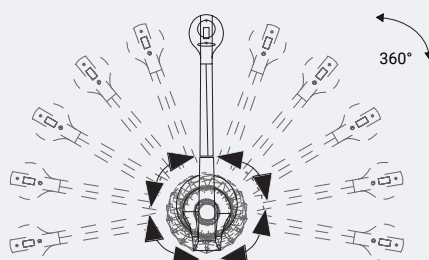
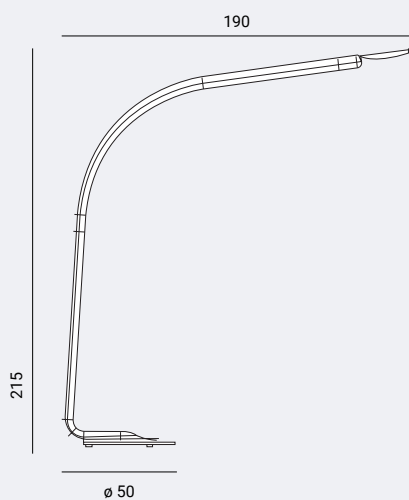

BARTOLI DESIGN 2017

# W O N D E R

*Astonishing brightness — and beauty*

La meraviglia della combinazione di più lampade Wonder di dimensioni, finiture e altezze diverse ha la stessa luminosa bellezza del vetro borosilicato con cui sono realizzate le singole canne, in finitura trasparente o fumé.

Combining more Wonder lamps in different dimensions, finishings and heights is astonishing as the luminous beauty of the borosilicate glass with which every single rod is made, in transparent or fume finishing.

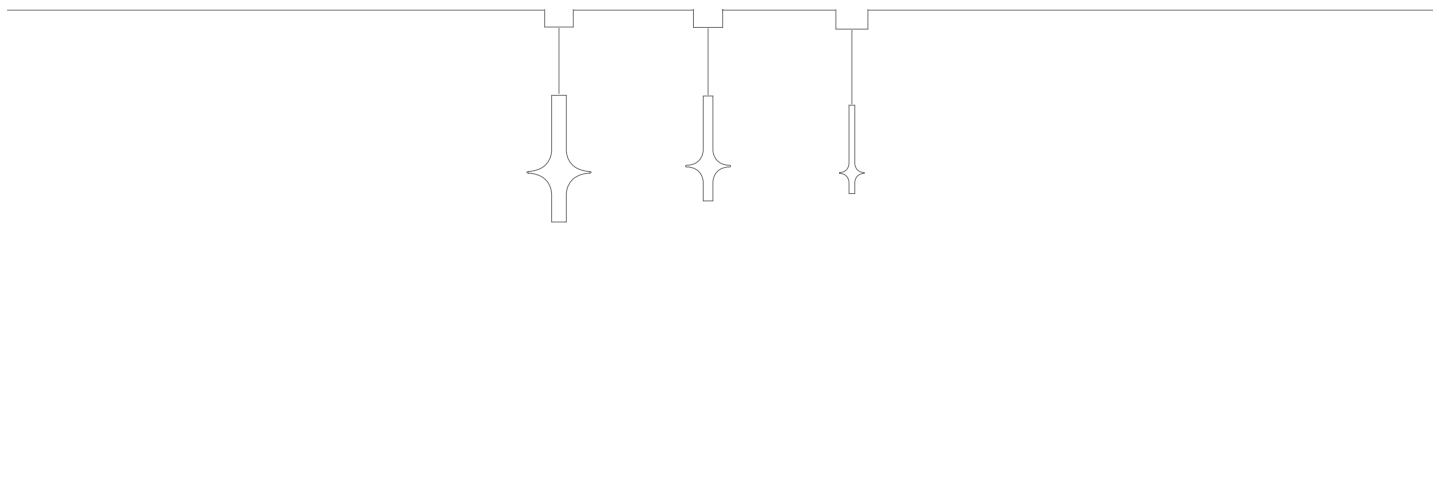















# WONDER *Bartoli Design, 2017*

## 1504

Lampada a sospensione con struttura in metallo nei colori opachi: oro, oro rosa o grafite. Diffusore in vetro borosilicato trasparente o fumé, disponibile in tre dimensioni: large, medium e mini. Rosone singolo nelle stesse finiture della struttura. Utilizzabile come elemento singolo o multiplo.

Pendant with metal structure in the matt colours: gold, rose gold or graphite. Shade in transparent or fume borosilicate glass, supplied in three sizes: large, small and mini. Single canopy in the same finishes of the structure Available as single element or in cluster.

## STRUTTURA METALLO / METAL STRUCTURE



Oro opaco  
Matt gold



Oro rosa opaco  
Matt rose gold



Grafite opaco  
Matt graphite

## VETRO / GLASS



Trasparente  
Transparent



Fumé  
Fumé

## SORGENTE / SOURCE

4W LED 3000 K - 400 lm

## SOSPENSIONE / SUSPENSION

1504-23  
large

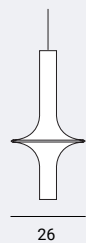

1504-21  
medium

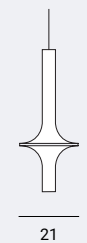

1504-20  
mini

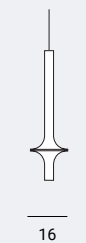

Rosone  
Canopy



Piastre a pag. 364  
plates p. 364

UMBERTO ASNAGO 2015

# W O O D Y

*The value — of simplicity*

Una forma essenziale e iper-contemporanea vestita della ricchezza decorativa del marmo di Carrara: il minimalismo non è mai stato più lussuoso.

A minimal and contemporary shape, along with the decorative opulence of Carrara marble: minimalism has never been so luxurious.







*Minimalism  
has never been so luxurious —*









# WOODY *Umberto Asnago, 2015*

## 1406

Lampade a sospensione realizzata in: legno noce canaletto, rovere grigio o in marmo bianco Carrara.

Pendants lamp in walnut wood, grey oak or in Carrara white marble.

## FINITURE / FINISHES

-  **Noce Canaletto**  
Canaletto walnut
-  **Marmo bianco Carrara**  
White Carrara marble
-  **Rovere grigio**  
Grey oak

## SORGENTE / SOURCE

**1406-23**  
25,5W 24v LED 3000 K

**1406-21**  
12W 24v LED 3000 K

## SOSPENSIONE / SUSPENSION

**1406-23**  
large

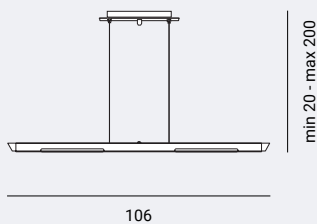

**1406-21**  
small

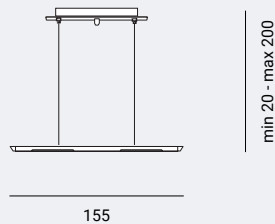





*Una collezione dove l'elemento paralume è protagonista,  
un classico made in Penta da riscoprire negli ambienti domestici.*

# OUR HERITAGE

*A collection where the lampshade is the protagonist,  
a classic Made in Penta to be rediscovered in the cosy setting of a home.*

# NEW CLASSIC

*Reinventing — the table lamp*

Reinterpretazione sofisticata del classico abat-jour, New classic ha una base a bottiglia in vetro di diverse forme e un paralume in tessuto – o in materiale traslucido, per un ulteriore tocco di modernità.

Glamorously reinventing the table lamp, New classic has a glass bottle in different shapes as a base and a shade of fabric or translucent material, for a fresh, contemporary look.

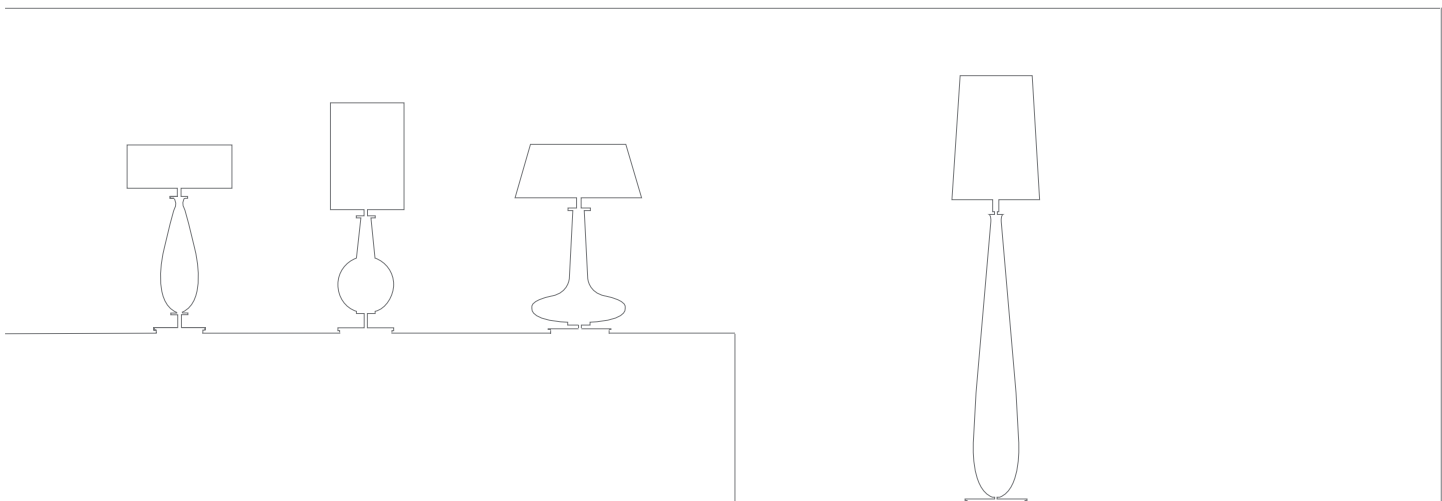



Bon Ton terra  
Bon Ton Floor













Bon Ton tavolo  
Bon Ton table





Desir tavolo  
Desir table









Pascià tavolo  
Pascià table









# NEW CLASSIC *Umberto Asnago 2003/2008*

## 0204-5-6

Lampade con struttura in metallo grafite opaco e vetro soffiato nei colori: trasparente, fumé, ambra, rubino, blu, verde oliva. Paralumi intercambiabili in varie misure nei tessuti della collezione, escluso plissé seta a mano. Chiusura superiore totale in plexiglas per lampada da tavolo.

Lamps with structure in matt graphite and blown glass in the following colours: transparent, fumé, amber, ruby, blue, olive-green. Interchangeable shades in different sizes in the fabrics of the collection, hand-made silk plissé excluded. Complete top closure in plexiglas for table lamp only.

## PARALUME / SHADE



Tessuti della collezione  
Fabrics of the collection

## VETRO / GLASS



Trasparente  
Transparent



Fumé  
Fumé



Ambra  
Amber



Rubino  
Ruby



Blu  
Blue



Verde oliva  
Olive-green

## TERRA / FLOOR

**0204-10**  
Bon Ton

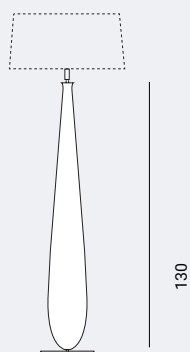

**0200-93**  
Low semicone

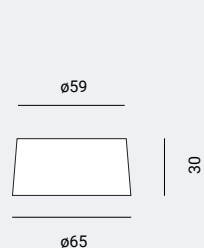

**0200-94**  
High semicone

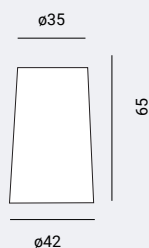

## SORGENTE / SOURCE

**0204-00**  
1 x 10W LED E27

**0205-00**  
1 x 10W LED E27

**0206-00**  
1 x 10W LED E27

**0204-10**  
1 x 10W LED E27

## TAVOLO / TABLE

**0204-00**  
Bon Ton

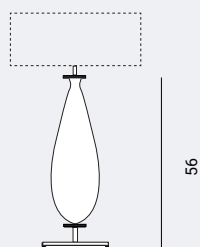

**0205-00**  
Desir

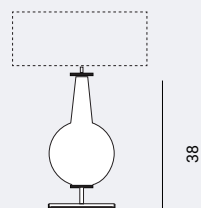

**0206-00**  
Pascià

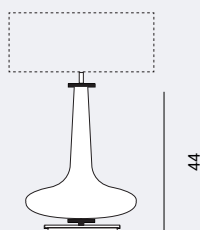

**0200-90**  
Semicone

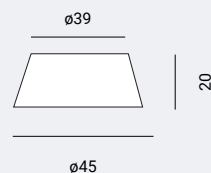

**0200-91**  
High cylinder

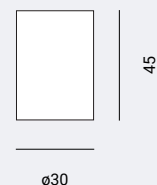

**0200-92**  
Low cylinder

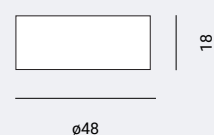

UMBERTO ASNAGO 2013

# T I C & T O C

*As time — goes by*

Luce, trasparenza, leggerezza: la collezione Tic/Toc si compone di due lampade diverse ma affini. La prima è completamente in vetro colorato con un'anima luminosa, la seconda unisce una base a sfera di vetro a un paralume in tessuto.

Light, transparency, lightness: Tic/Toc collection consists of two different but similar lamps. The first one is coloured glass with a bright soul, the second combines a glass sphere with a fabric shade.

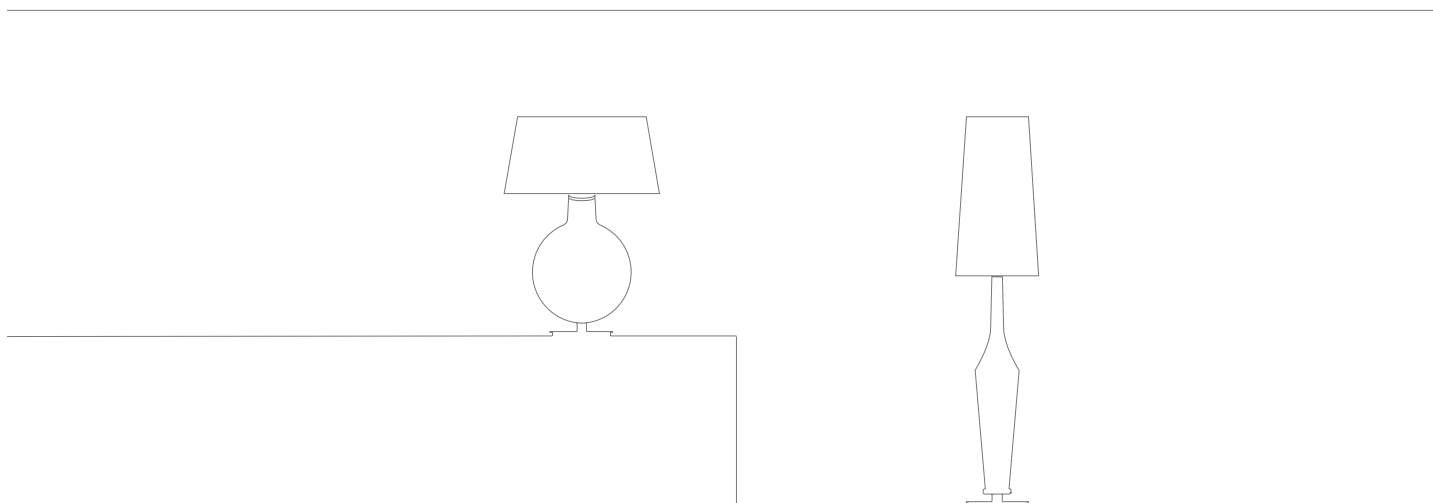



Tic









Toc







# TIC & TOC *Umberto Asnago, 2013*

## 1303-4

Lampade con struttura in metallo grafite opaco e vetro soffiato nei colori: trasparente, fumé, rubino, blu, oliva, ambra. Paralumi intercambiabili nelle forme e nei tessuti della collezione. Escluso plissé seta a mano.

Lamps with structure in matt graphite and blown glass in the following colours: transparent, fumé, ruby, blue, olive-green, amber. Interchangeable shades in different sizes in the fabrics of the collection. Hand-made silk plissé excluded.

## PARALUME / SHADE



Tessuti della collezione  
Fabrics of the collection

## VETRO / GLASS



Trasparente  
Transparent



Rubino  
Ruby



Fumé  
Fumé



Blu  
Blue



Ambra  
Amber



Verde oliva  
Olive-green

## SORGENTE / SOURCE

**1303-00**  
1 x 10W LED E27

**1304-00**  
1 x 10W LED E27

## TAVOLO / TABLE

### 1303-00

Tic

ø20/28



56

80

### 1303-90

Glass shade

ø22



48

ø28

diffusore in vetro  
glass shade

### 1303-91

Fabric Shade

ø20



ø28

### 1304-00

Toc

ø50/60

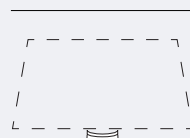

30

52

### 1304-91

Fabric Shade

ø50



30

60



UMBERTO ASNAGO 2006

# T O S C A

*Elegant — and pure*

Un sostegno essenziale in metallo supporta un paralume rettangolare in tessuto in questa lampada da terra o da tavolo che mostra tutta l'eleganza della semplicità, per un effetto luminoso di grande atmosfera.

A minimal metal support sustains a rectangular fabric shade in this floor or table lamp which shows all the elegance of simplicity, for a light effect of great atmosphere.

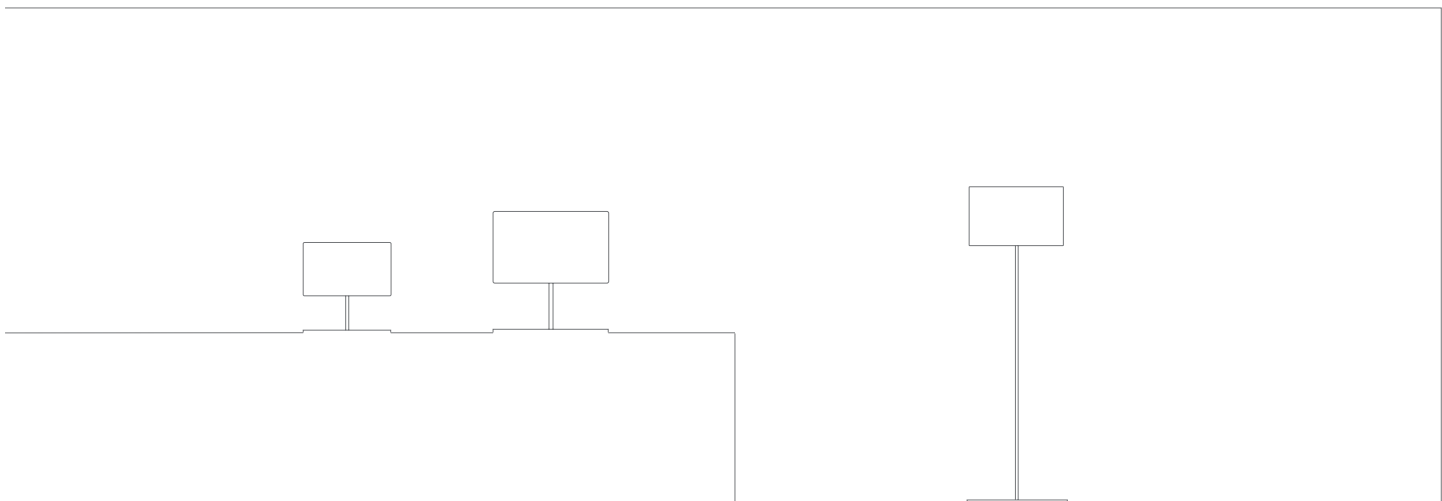













PENTIA

# TOSCA *Umberto Asnago, 2006*

## 0601

Lampade con struttura in metallo grafite opaco. Diffusore nei tessuti della collezione con chiusura superiore in plexiglas.

Lamps with structure in matt graphite. Shade in the fabrics of the collection with top closure in plexiglas.

## PARALUME / SHADE



Tessuti della collezione  
Fabrics of the collection

## STRUTTURA METALLO / METAL STRUCTURE



Grafite opaco  
Matt graphite

## SORGENTE / SOURCE

**0601-03**  
2 x 5W LED E14

**0601-01**  
2 x 5W LED E14

**0601-10**  
2 x 10W LED E27 

## TAVOLO / TABLE

**0601-03**  
large

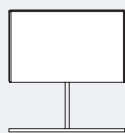

41

**0601-90**  
large

40x13,5



24

**0601-01**  
small



31

**0601-91**  
small

30x10



18

## TERRA / FLOOR

**0601-10**



162

**0601-92**

50x20



30



# BRIDGET

## COLLECTION

*Night reading — perfection*

Una famiglia di lampade dalla forte vocazione progettuale. Nella versione da tavolo dotata di braccio mobile, il paralume si può spostare in base alle esigenze rendendo Bridget la perfetta lampada da lettura.

A family of lamps with a strong design vocation. In the table version, it is equipped with an adjustable arm, so that the shade can be moved according to requirements, and Bridget becomes the perfect reading lamp.

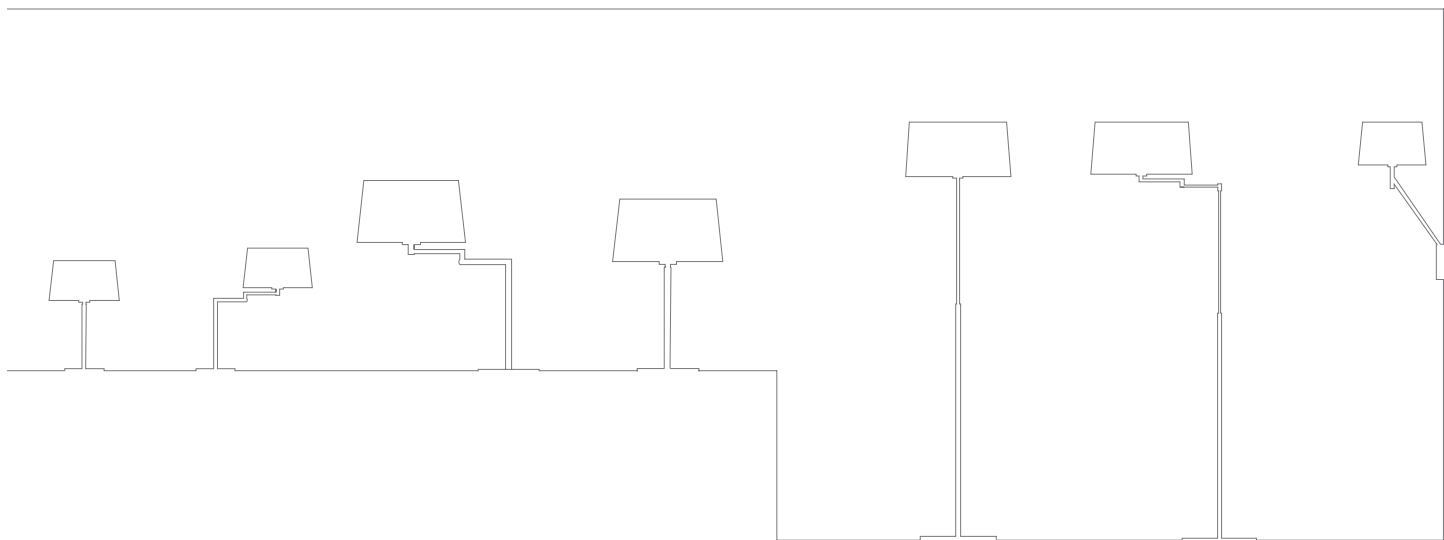







# BRIDGET COLLECTION

## 1003

Lampade con struttura in metallo nichel satinato. Paralume semicono nei tessuti della collezione. (Escluso plissé seta a mano e PVC specchiato). A richiesta per quantitativi: ulteriori finiture metalliche e plissé seta a mano.

Lamps with structure in nickel satin metal. Semicone shade in the fabrics of the collection. (Hand-made silk plissé and mirroring PVC excluded). On demand for quantity: further metal finishes and hand-made silk plissé.

## PARALUME / SHADE



Tessuti della collezione  
Fabrics of the collection

## STRUTTURA METALLO / METAL STRUCTURE



Metallo nichel satinato  
Nickel satin metal

## SORGENTE / SOURCE

**1003-04**  
8W LED E27

**1003-10**  
10W LED E27

**1003-03**  
8W LED E27

**1003-16**  
10W LED E27

**1003-02**  
5W LED E14

**1003-31**  
5W LED E14

**1003-01**  
5W LED E14

## TAVOLO / TABLE

**1003-03**  
large extensible



**1003-04**  
large extensible adjustable

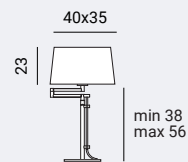

**1003-90**  
large shade

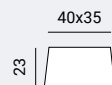

## APPLIQUE / WALL

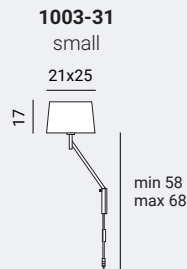

**1003-01**  
small extensible



**1003-02**  
small extensible adjustable



**1003-91**  
small shade



## TERRA / FLOOR

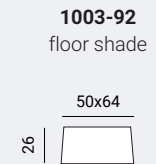
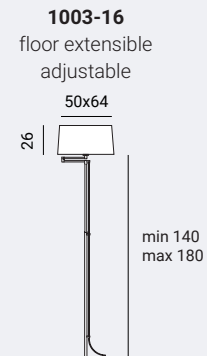
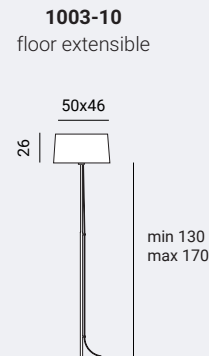



# SOSPENSIONI IN TESSUTO

*Sospensioni e paralumi in tessuto hanno segnato l'inizio della nostra storia. Ancora oggi li facciamo a mano uno a uno, con tessuti e passamanerie di pregio.*



# FABRIC SUSPENSIONS

*Fabric suspension lamps and lampshades marked the beginning of our history. As of today, we still produce each of them by hand, with precious fabrics and trimmings.*



# CILINDRO

*Classic and soft — to the touch*

Un oggetto dalle linee pulite che diventa protagonista dello spazio, esaltando attraverso la luce la morbidezza del tessuto.

An object with clean lines becomes the protagonist of the space, enhancing the softness of the fabric through light.

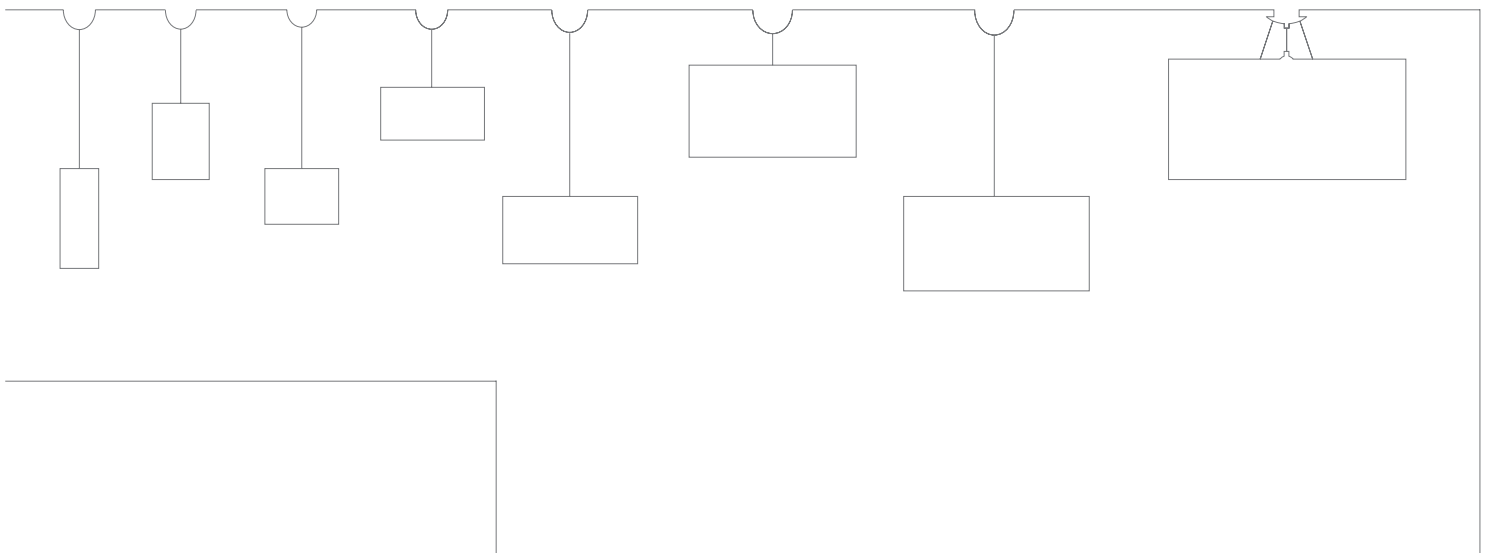



Linone verde lime  
Lime green lawn

# CILINDRO ALTO

*A beautiful — presence*

Una sospensione in tessuto dalla forma cilindrica allungata, da usare sola o abbinata ad altre di diametri e altezze diverse, anche in differenti finiture.

A fabric suspension with an elongated cylindrical shape, to be used alone or combined with others of different diameters and heights, in different finishings as well.





Seta rosso e bianco  
Red and white silk

# CILINDRI BASSI

*A cozy — and welcoming light*

Una sospensione dal fascino sofisticato: il paralume in tessuto lascia filtrare una luce morbida e accogliente, perfetta per i luoghi della convivialità.

A suspension lamp with a sophisticated charm: the fabric shade leaks a warm, welcoming light, which is perfect for convivial spaces.



Linone corca  
Cord lawn



Linone cocco  
Coco lawn



Linone melograno  
Pomegranata lawn



# CILINDRO DOPPIO

*From tradition — to contemporary*

Uno dentro l'altro, i cilindri creano effetti diversi: dalla versione classica, con doppio paralume in tessuto, a quella più contemporanea, con cilindro interno in PVC specchiato.

One inside the other, the cylinders create different effects: from the classic version, with a double fabric shade, to the more contemporary one, with an internal mirror-finish PVC cylinder.

Pvc argento interno - seta nero esterno  
Silver pvc inside - black silk outside



# UP - DOWN

*The adjustable — lampshade*

Il classico paralume rinasce in versione iper-contemporanea in Up&Down, sospensione in tessuto o PVC specchiato con cavo e contrappeso in metallo, da regolare in altezza.

The classic lampshade is new again in this hyper-contemporary version of Up&Down, a suspension lamp in fabric or mirror-finish PVC with a metal cable and counterweight, to be adjusted in height.



Pvc bronzo  
Bronze pvc



TESSUTO - FABRICS

# LUXURY

*Light and pleats — an inseparable pair*

Luxury è una sospensione in tessuto resa più ricca dalla lavorazione a plissé. È disponibile nelle forme semiconica, cilindrica e rettangolare.

Luxury is a fabric suspension lamp, enriched by the pleated handwork. It is available in semi-conic, cylindrical and rectangular shape.

Plissé seta a mano tabacco  
Hand-made silk plissé tobacco





TESSUTO - FABRICS

# SLIDE

*Graceful — and bright ceilings*

Il cilindro basso in tessuto riletto in versione plafoniera,  
per gli spazi di casa e quelli del contract.

The short fabric cylinder in a wall lamp version, for home  
and public spaces.

Seta avorio  
Ivory silk



R E T T A N  
G O L A R E

*Geometry — has never been softer*

Le curve sinuose dei cilindri lasciano spazio alla geometria di Rettangolo, una sospensione rigorosa riscaldata dalla finitura in tessuto.

The sinuous curves of the cylinders leave space to the geometry of Rettangolo, a severe suspension light, made softer by the fabric finishings.





Lino grezzo  
Unbleached linen

TESSUTO - FABRICS

# VANITY

*An easy — atmosphere*

La stessa morbida qualità della luce e la bellezza tattile delle sospensioni in tessuto in versione applique.

The same soft quality of light and the tactile beauty of the fabric suspensions, here in the wall lamp version.

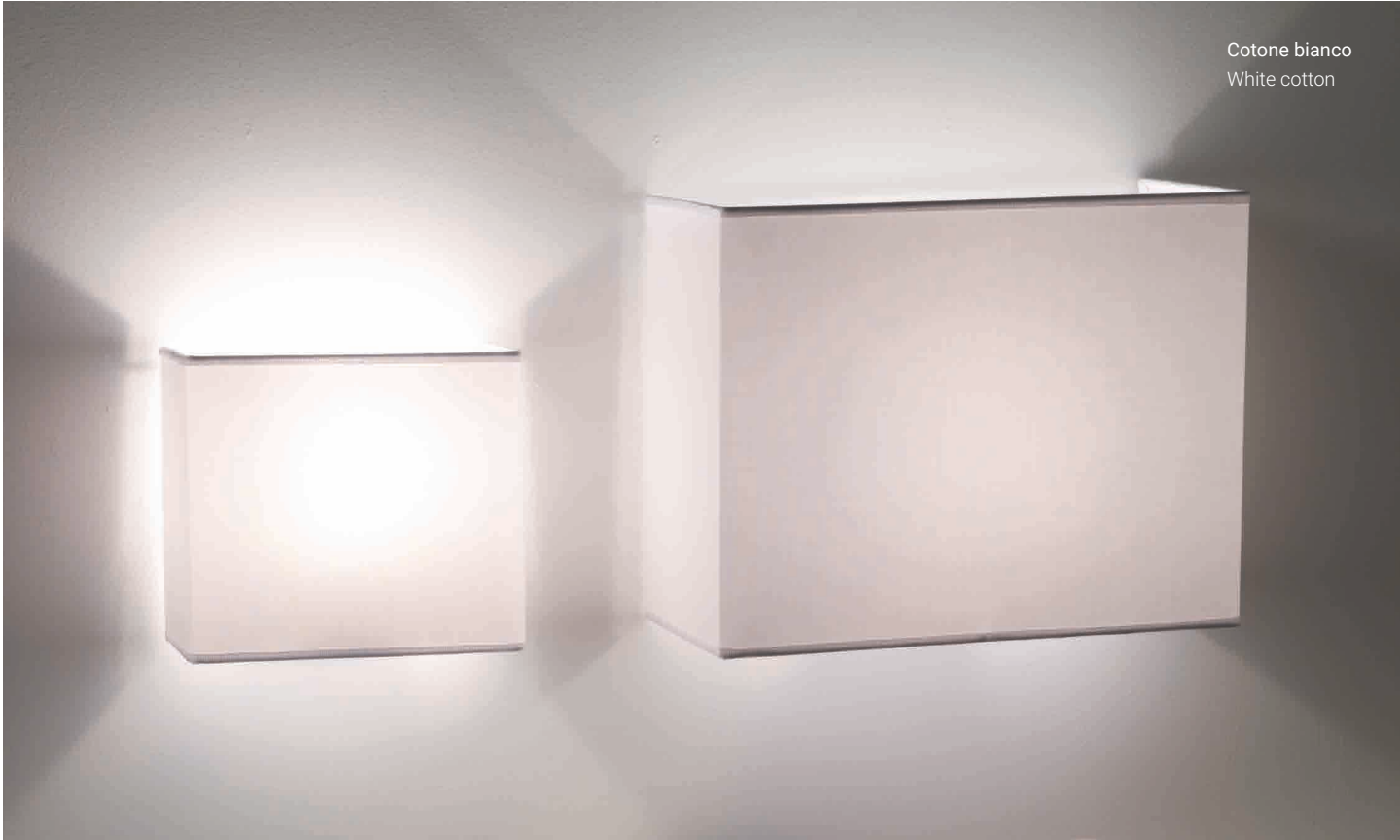

Cotone bianco  
White cotton



Cotone bianco  
White cotton



TESSUTO - FABRICS

# CLUB HOUSE

*Classic — with a twist*

Club House è una collezione dall'indole decorativa che rilegge con ironia il classico paralume in seta con passamaneria a contrasto.

Club House is a decorative collection that ironically reinterprets the classic silk shade with contrasting trimmings.









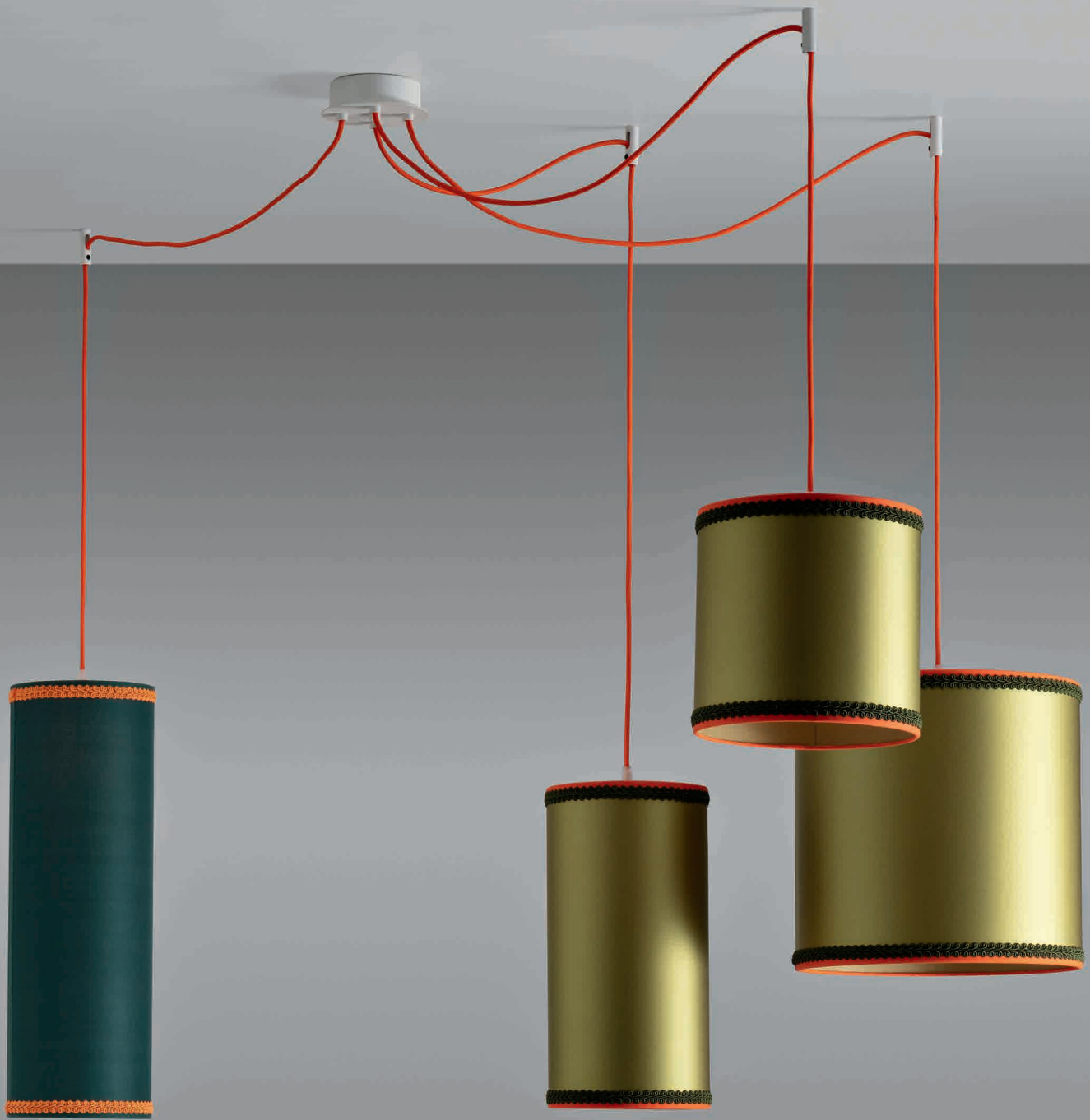

## Esempio composizioni

### Su progetto a richiesta rosoni e composizioni personalizzate

Composition examples

On demand special canopies and compositions for custom projects

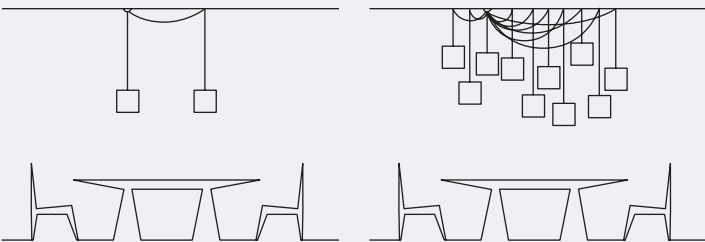
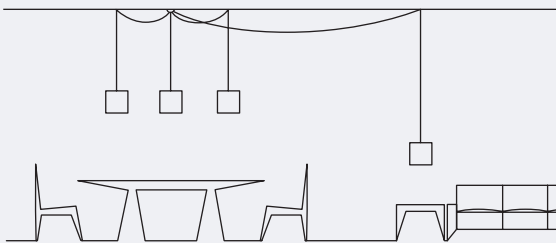
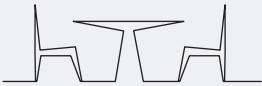
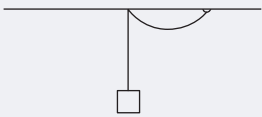
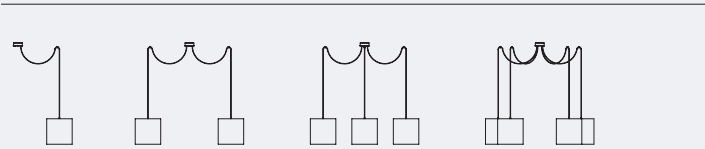

ROSONI / CANOPIES CLUB HOUSE

**AD01-T-13-01**  
white

**AD18-T-13-01**  
titanium



**AD01-T-13-02**  
white

**AD18-T-13-02**  
titanium



**AD01-T-13-03**  
white

**AD18-T-13-03**  
titanium



**AD01-T-13-04**  
white

**AD18-T-13-04**  
titanium



**AD01-T-13-08**  
white

**AD18-T-13-08**  
titanium







1402-30-11

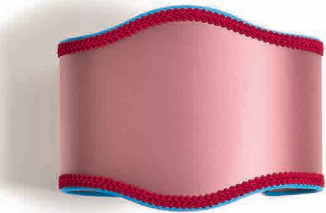

1402-30-07

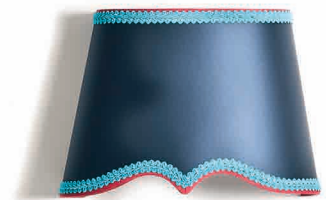

1402-30-06



1402-30-02

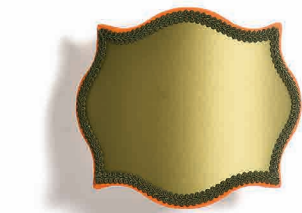

1402-30-01

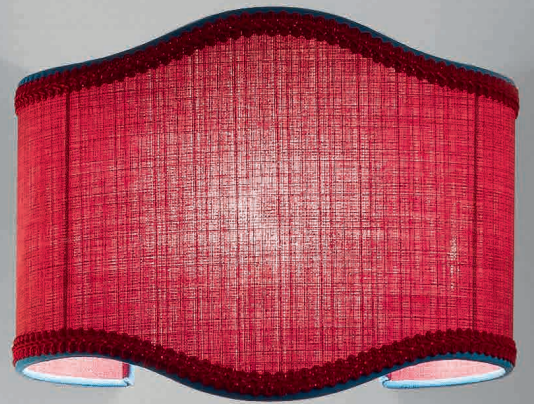

**Cavo elettrico in cotone colorato**  
Electrical cable in cotton colour



**Blu**  
Blue



**Turchese**  
Turquoise



**Arancio**  
Orange



**Arancio**  
Orange



**Turchese**  
Turquoise

Linone - Lawn



**Blu Denim**  
Blue Denim



**Melograno**  
Pomegranate



**Verde Lime**  
Lime green



**Cocco**  
Coco



**Corda**  
Cord

Raso di seta - Silk satin



**Blu Marine**  
Blue Marine

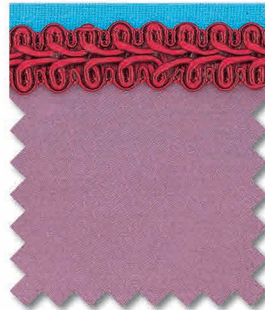

**Malva**  
Mauve



**Salvia**  
Salvia



**Fango**  
Fango



**Madreperla**  
Pearl





# TESSUTO / FABRICS

## CILINDRI p.332

**9229-20**  
cylinder

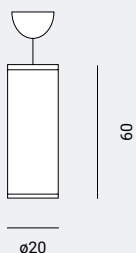

**9229-21**  
cylinder

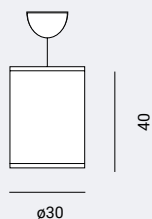

**9229-22**  
cylinder

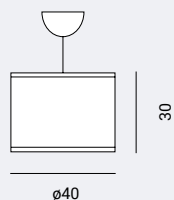

**9229-23**  
cylinder

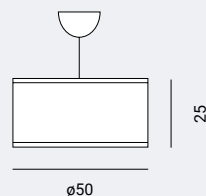

**9229-24**  
cylinder

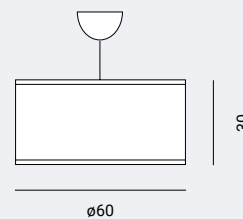

**9229-25**  
cylinder

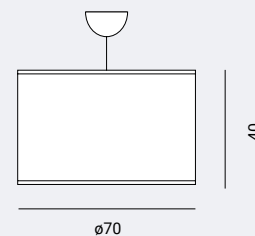

**9229-26**  
cylinder

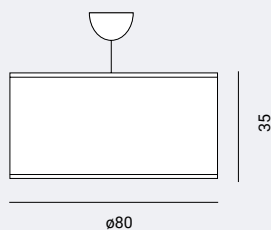

**9229-27**  
cylinder

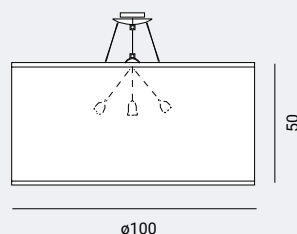

**9229-29**  
double cylinder

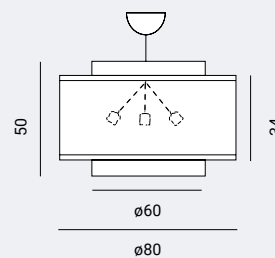

**9229-28**  
cylinder

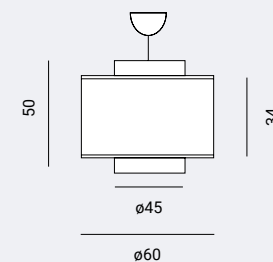

**0604-20**  
low cylinder

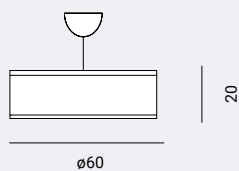

**0604-21**  
low cylinder

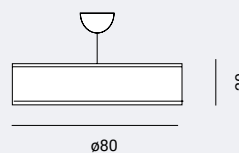

**0604-22**  
low cylinder

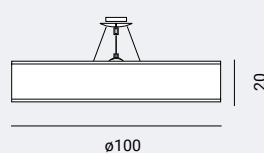

**0610-20**  
high cylinder



**0605-20**  
high cylinder

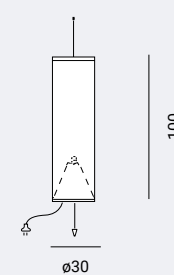

## SORGENTE / SOURCE

**9229-20**  
10W LED E27

**9229-24**  
10W LED E27

**9229-28**  
3 x 10W LED E27

**0604-22**  
3 x 10W LED E27

**9229-21**  
10W LED E27

**9229-25**  
10W LED E27

**9229-29**  
3 x 10W LED E27

**0610-20**  
10W LED E27

**9229-22**  
10W LED E27

**9229-26**  
10W LED E27

**0604-20**  
3 x 10W LED E27

**0605-20**  
10W LED E27

**9229-23**  
10W LED E27

**9229-27**  
3 x 10W LED E27

**0604-21**  
3 x 10W LED E27

**1005-20**  
square

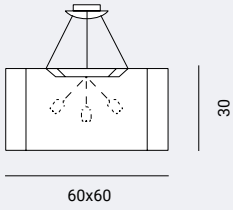

**1005-22**  
square

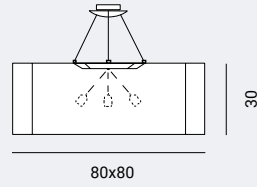

**1005-24**  
square

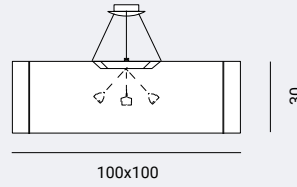

**1025-20**  
cylinder

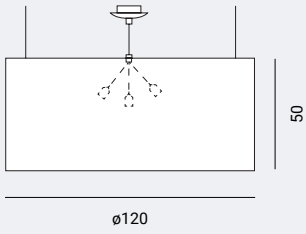

**1030-20**  
cylinder

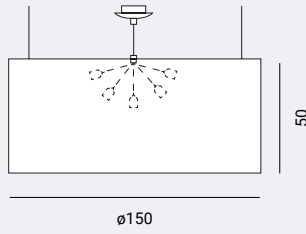

**1031-20**  
cylinder

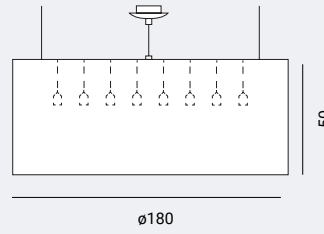

**1032-20**  
cylinder

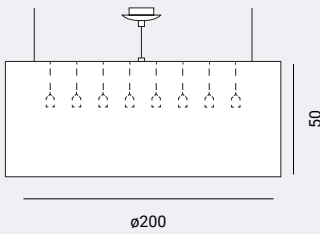

**1033-20**  
rectangular

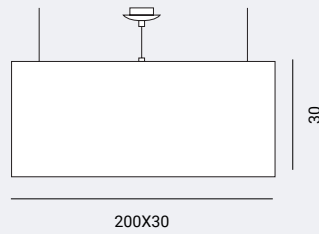

**1034-20**  
rectangular

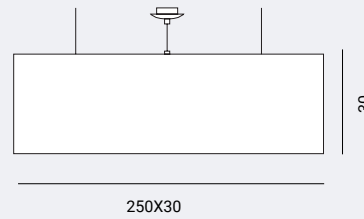

**UP-DOWN** p. 340

**1009-20**

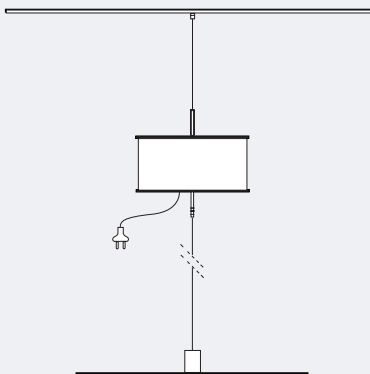

**SORGENTE/ SOURCE**

**1005-20**  
3 x 10W LED E27

**1005-21**  
3 x 10W LED E27

**1005-22**  
3 x 10W LED E27

**1025-20**  
3 x 10W LED E27

**1030-20**  
5 x 10W LED E27

**1031-20**  
8 x 10W LED E27

**1032-20**  
8 x 10W LED E27

**1033-20**  
4 x 10W LED E27

**1034-20**  
4 x 10W LED E27

**1009-20**  
3 x 5W LED E14



# TESSUTO / FABRICS

LUXURY p. 342

**0607-20**  
semicone

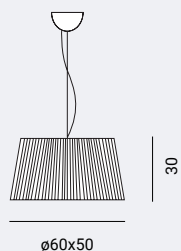

**0607-21**  
semicone

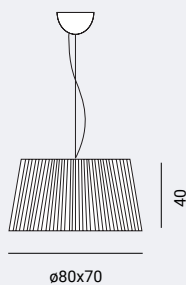

**0607-22**  
semicone

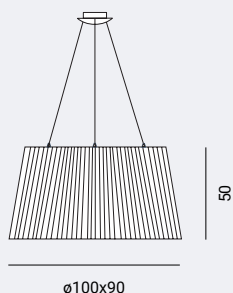

**0607-23**  
cylinder

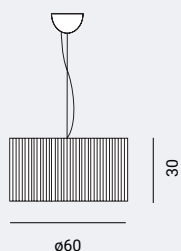

**0607-24**  
cylinder

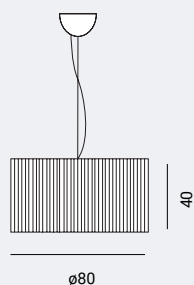

**0607-25**  
cylinder

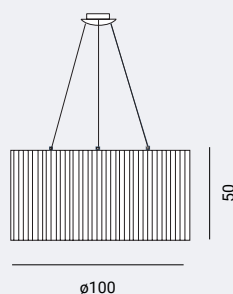

**0607-26**  
rectangular

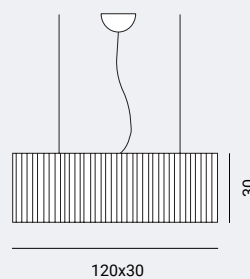

SLIDE p. 344

**0604-40**  
small round

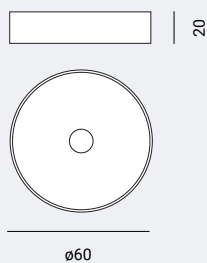

**0604-41**  
medium round

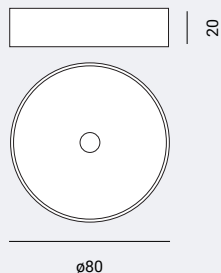

**0604-42**  
large round

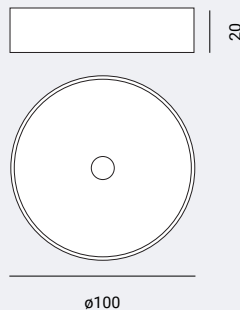

**1005-40**  
small square

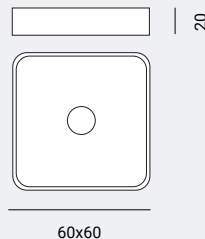

**1005-41**  
medium square

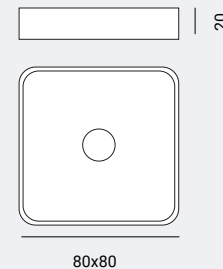

**1005-42**  
large square

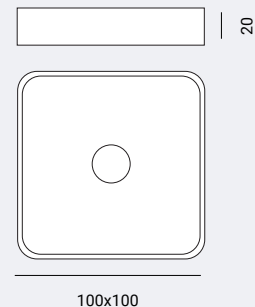

SORGENTE/ SOURCE 

**0607-20**  
3 x 10W LED E27

**0607-23**  
3 x 10W LED E27

**0607-26**  
3 x 10W LED E27

**0604-42**  
3 x 10W LED E27

**1005-42**  
3 x 10W LED E27

**0607-21**  
3 x 10W LED E27

**0607-24**  
3 x 10W LED E27

**0604-40**  
3 x 10W LED E27

**1005-40**  
3 x 10W LED E27

**0607-22**  
3 x 10W LED E27

**0607-25**  
3 x 10W LED E27

**0604-41**  
3 x 10W LED E27

**1005-41**  
3 x 10W LED E27

**CLUB HOUSE** p. 350

**1402-20**

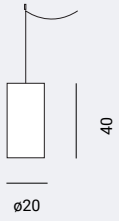

**1402-21**

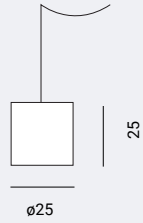

**1402-22**

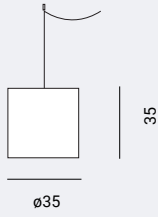

**Rosone**  
Canopy

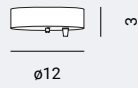

**1402-24**  
trendy large

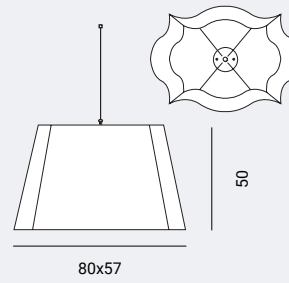

**1402-23**  
trendy small

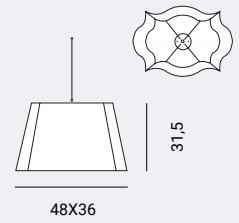

**1402-30**



**1402-31**



**1402-32**



**1402-33**



**1402-34**

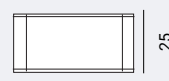

**VANITY** p. 348

**9540-31**

large rectangular

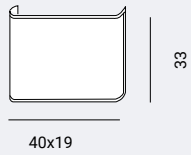

**9540-30**

small rectangular

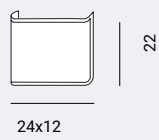

**9540-33**

large round

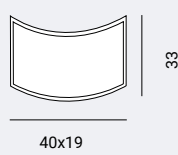

**9540-32**

small round

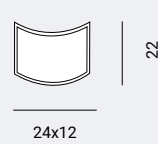

**SORGENTE/ SOURCE**

**1402-20**  
10W LED E27

**1402-23**  
10W LED E27

**1402-31**  
10W LED E27

**1402-34**  
10W LED E27

**9540-32**  
5W LED E14

**1402-21**  
10W LED E27

**1402-24**  
3 x 10W LED E27

**1402-32**  
10W LED E27

**9540-30**  
5W LED E14

**9540-33**  
10W LED E27

**1402-22**  
10W LED E27

**1402-30**  
10W LED E27

**1402-33**  
10W LED E27

**9540-31**  
10W LED E27

# PIASTRE / PLATES

A-PIASTRE / PLATES ACORN, GLO, LIT, MOM

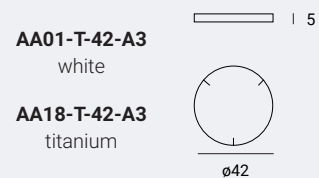

**Piastra tonda con max 3 attacchi**  
Round plate with max 3 fittings

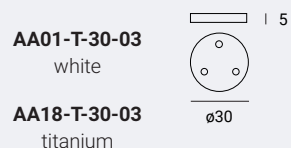

**Piastra tonda con max 3 attacchi**  
Round plate with max 3 fittings

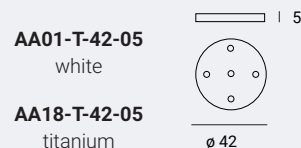

**Piastra tonda con max 5 attacchi**  
Round plate with max 5 fittings

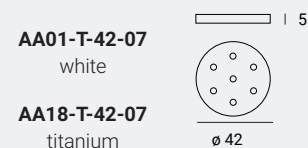

**Piastra tonda con max 7 attacchi**  
Round plate with max 7 fittings

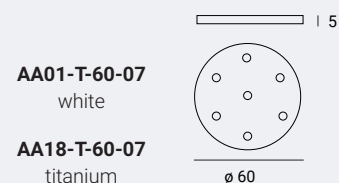

**Piastra tonda con max 7 attacchi**  
Round plate with max 7 fittings

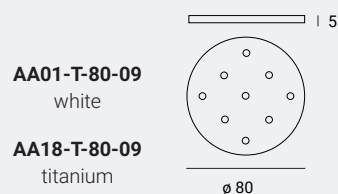

**Piastra tonda con max 9 attacchi**  
Round plate with max 9 fittings

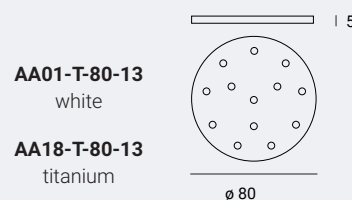

**Piastra tonda con max 13 attacchi**  
Round plate with max 13 fittings

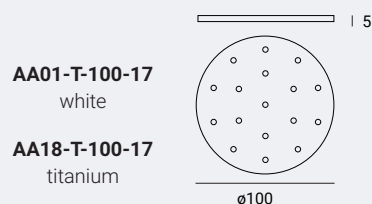

**Piastra tonda con max 17 attacchi**  
Round plate with max 17 fittings

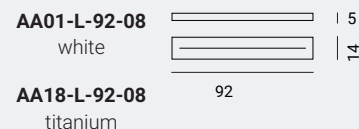

**Piastra lineare con max 8 attacchi**  
Round plate with max 8 fittings

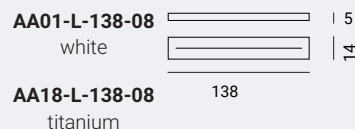

**Piastra lineare con max 8 attacchi**  
Round plate with max 8 fittings

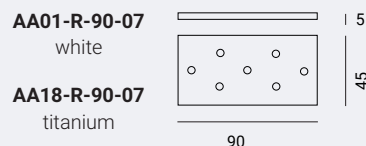

**Piastra rettangolare con max 7 attacchi**  
Rectangular plate with max 7 fittings

D-PIASTRE / PLATES STORM, SPOON



**max 3 attacchi**  
max 3 fittings

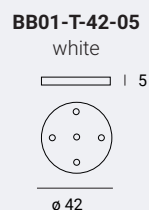

**max 5 attacchi**  
max 5 fittings



**max 7 attacchi**  
max 7 fittings

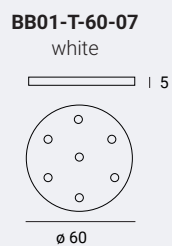

**max 7 attacchi**  
max 7 fittings

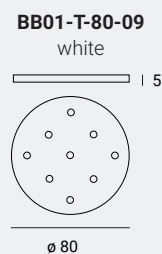

**max 9 attacchi**  
max 9 fittings

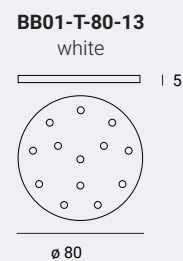

**max 13 attacchi**  
max 13 fittings

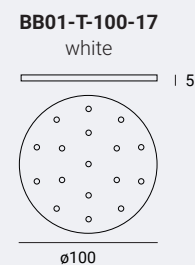

**max 17 attacchi**  
max 17 fittings



**BB01-L-92-08**  
white  
max 8 attacchi  
max 8 fittings

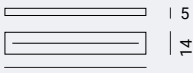

92  
14

**BB01-L-138-08**  
white  
max 8 attacchi  
max 8 fittings

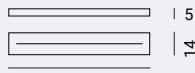

138  
14

**BB01-R-90-07**  
white  
max 7 attacchi  
max 7 fittings

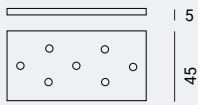

90  
45

C-PIASTRE / PLATES CLIP

**CC01-T-30-03**  
white  
max 3 attacchi  
max 3 fittings

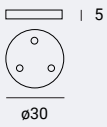

5  
ø30

**CC01-T-42-05**  
white  
max 5 attacchi  
max 5 fittings

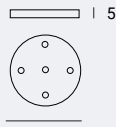

5  
ø 42

**CC01-T-42-07**  
white  
max 7 attacchi  
max 7 fittings

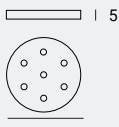

5  
ø 42

**CC01-T-60-07**  
white  
max 7 attacchi  
max 7 fittings

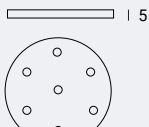

5  
ø 60

**CC01-T-80-09**  
white  
max 9 attacchi  
max 9 fittings

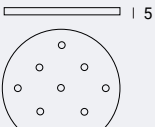

5  
ø 80

**CC01-T-80-13**  
white  
max 13 attacchi  
max 13 fittings

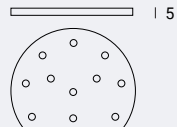

5  
ø 80

**CC01-T-100-17**  
white  
max 17 attacchi  
max 17 fittings

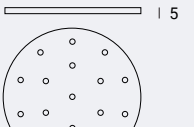

5  
ø100

**CC01-L-92-08**  
white  
max 8 attacchi  
max 8 fittings

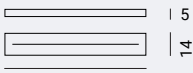

92  
14

**CC01-L-138-08**  
white  
max 8 attacchi  
max 8 fittings



138  
14

**CC01-R-90-07**  
white  
max 7 attacchi  
max 7 fittings

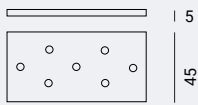

90  
45

D-PIASTRE / PLATES WONDER

**DD01-T-30-03**  
white  
max 3 attacchi  
max 3 fittings

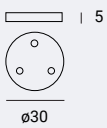

5  
ø30

**DD01-T-42-05**  
white  
max 5 attacchi  
max 5 fittings

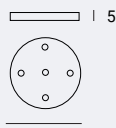

5  
ø 42

**DD01-T-42-07**  
white  
max 7 attacchi  
max 7 fittings

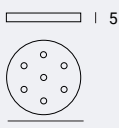

5  
ø 42

**DD01-T-60-07**  
white  
max 7 attacchi  
max 7 fittings

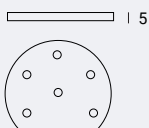

5  
ø 60

**DD01-T-80-09**  
white  
max 9 attacchi  
max 9 fittings

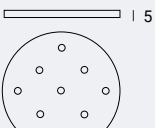

5  
ø 80

**DD01-T-80-13**  
white  
max 13 attacchi  
max 13 fittings

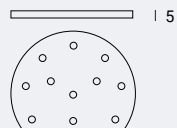

5  
ø 80

**DD01-T-100-17**  
white  
max 17 attacchi  
max 17 fittings

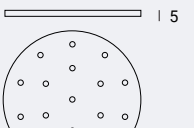

5  
ø100

**DD01-L-92-08**  
white  
max 8 attacchi  
max 8 fittings

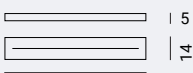

92  
14

**DD01-L-138-08**  
white  
max 8 attacchi  
max 8 fittings



138  
14

**DD01-R-90-07**  
white  
max 7 attacchi  
max 7 fittings



90  
45

# LEGENDA/ KEYS



Lampadina esclusa/ bulb not included



LED integrato/ integrated LED



Dimmer incluso/ Dimmer included

La tensione s'intende 230V, 50/60HZ o 120V, 60HZ a seconda dei paesi.  
Voltage: 230V, 50/60HZ or 120V, 60 HZ according to the country.

I lumen non sempre corrispondono. Verificare sempre le dimensioni. Rif. Leuci  
Lumen don't always match. Always check the dimensions. Ref. Leuci

Penta si riserva il diritto di apportare ai propri modelli, senza alcun preavviso, modifiche e migliorie che potrebbero variare l'estetica delle soluzioni pensate.  
Penta reserves the right to charge, better and improve its models without notice, also if these improvements might change the aestetical image of the proposed solutions.

I vetri realizzati rigorosamente a mano dal maestro vetraio rispettano le antiche e tradizionali tecniche di soffiatura. Ogni articolo è sottoposto a meticolosi controlli di qualità, pertanto apparenti difetti come bolle o variazioni dei toni di colore del vetro, sono riconosciuti come pregi e conferma della lavorazione artigianale.

Glasses are hand made and mounth blown by the master glass blower, according to the traditional techniques of blowing. Each item is carefully checked, therefore apparent imperfections, such as bubbles or nuances in the glass colour, have to be recognised as qualities and sign of the artisan's craftsmanship.



SISTEMA DI GESTIONE  
QUALITÀ CERTIFICATA  
AZIENDA CERTIFICATA

**ECOLIGHT**  
EFFICIENZA E PROFESSIONALITÀ PER L'AMBIENTE

PENTA srl aderisce al Consorzio Ecolight per l'attuazione delle direttive WEEE/RAEE 2002/95/CE e 2003/108/CE relative alla raccolta e smaltimento delle apparecchiature di illuminazione.

Penta srl takes part in Consorzio Ecolight for the implementation of directive WEEE/RAEE 2002/95/CE e 2003/1087/CE relating to collection and discharge of lighting fittings.





AD  
Nicola Gallizia

STYLING  
Carola Minotti

PHOTO  
Tiziano Sartorio

FOTOLITO  
GM studio 1Vr

STAMPA  
IMOCO GROUP

Printed: May 2019



PENTA is part of PENTA GROUP



**PENTA srl** · via Trieste, snc · 20821 Meda · (MB) · Italy  
T +39 0362 1869300  
[pentalight.it](http://pentalight.it) - [pentalightgroup.it](http://pentalightgroup.it) - [info@pentalight.it](mailto:info@pentalight.it)

**MADE IN ITALY 100%**

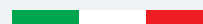



[pentalightgroup.it](http://pentalightgroup.it)