

ZONCA

L I G H T I N G



ZONCA  
LIGHTING



HAND MADE

9



CONTRACT

17



JACQUES  
GARCIA

61

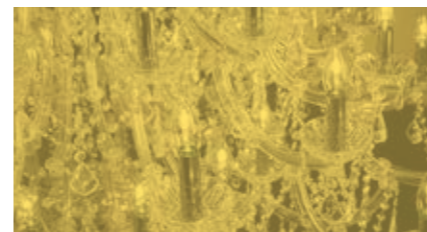

PRODUCTS

89

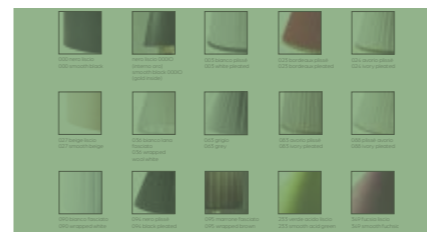

MATERIALS

199

HAND MADE

BESPOKE

RESTORATION

TAILOR MADE

ON DEMAND

CUSTOM

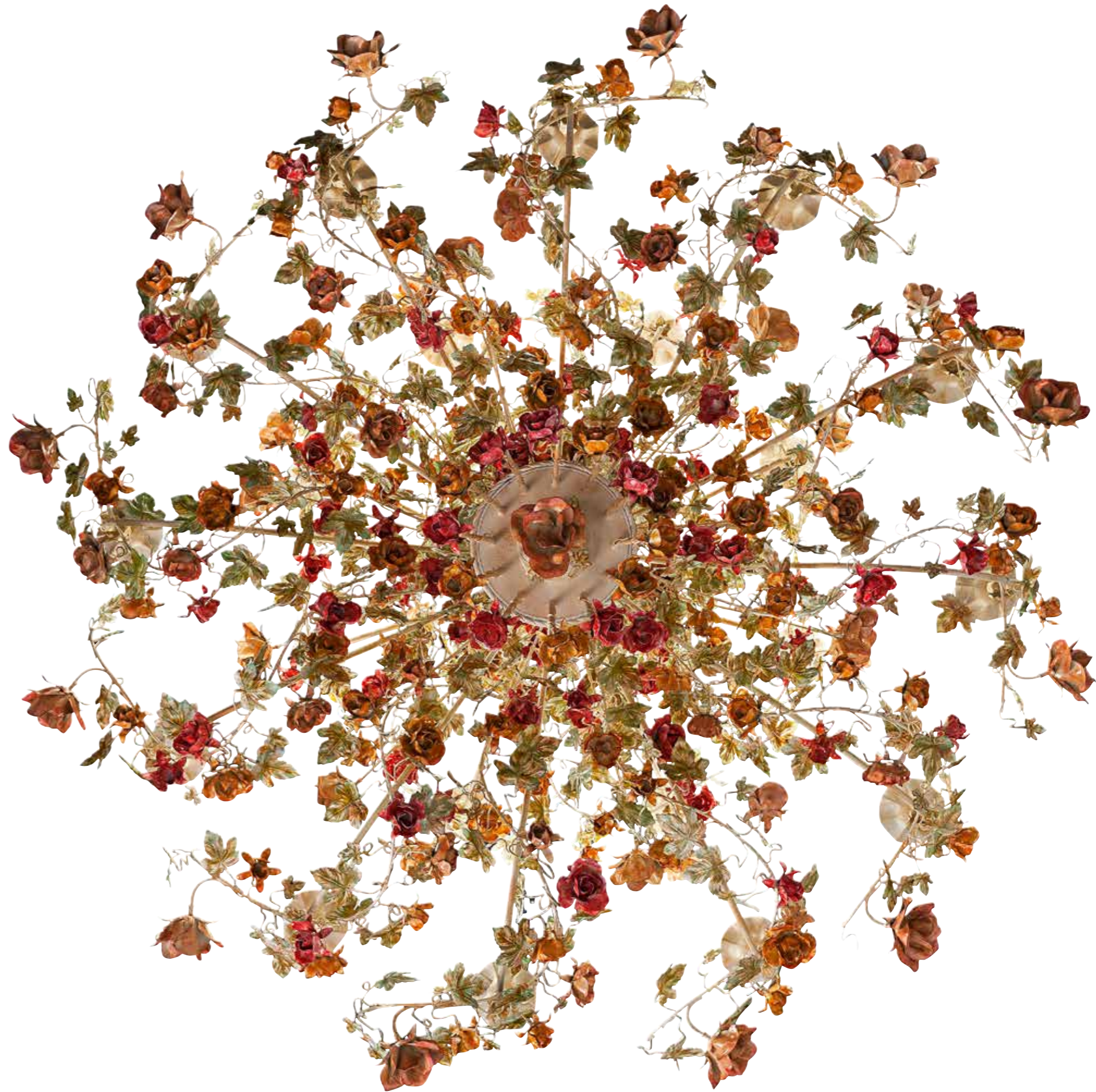

## OLTRE UN SECOLO DI LAMPADE

La flessibilità è un punto di forza che consente all'azienda di curare il prodotto seriale, il contract e il custom made, con realizzazioni di ragguardevole prestigio.

Design, ricerca delle forme e dei materiali, cura nella esecuzione del prodotto, sono concetti tramandati con altri nomi e tradotti in linguaggio contemporaneo.

Oltre a disporre di propri progettisti interni, l'azienda affida la ricerca di nuove soluzioni formali ad alcuni fra i più celebri designer del panorama contemporaneo. Nascono così lampade dallo stile esclusivo, creazioni pensate per esibire la propria bellezza in ambientazioni di classe.

Zonca offre una gamma completa di prodotti e di servizi per le esigenze dell'hotel di classe: le creazioni Zonca donano luce ed eleganza a strutture alberghiere di altissimo livello.

Un successo dovuto anche alla capacità di realizzare prodotti personalizzati, nella stretta collaborazione fra l'azienda e i progettisti, gli architetti indicati dal cliente.

A tutto ciò, si aggiunge una curatissima assistenza post vendita: ecco perché queste realizzazioni soddisfano nel dettaglio qualunque requisito estetico e tecnico, aderendo alle aspettative dei più esigenti.

Oltre a disporre di propri progettisti interni, l'azienda affida la ricerca di nuove soluzioni formali ad alcuni fra i più celebri designer del panorama contemporaneo. Nascono così lampade dallo stile esclusivo, creazioni pensate per esibire la propria bellezza in ambientazioni di classe.

Bollicine e rilievi nei vetri artistici veneziani, cuciture e giunzioni a vista nei paralumi, leggere variazioni di colore su forniture diverse, sono tutte possibili imperfezioni nei nostri prodotti, creati in modo unicamente artigianale e nel rispetto della tradizione del made in Italy.



## OVER A CENTURY OF LIGHT



*Flexibility is a strength that allows the company to treat the product serial, contract and custom made, with remarkable achievements of prestige.*

*Design, research of forms and materials, care in the execution of the product, the concepts are passed by other names and translated into contemporary language.*

*In addition to its own in-house designers, the company relies on the search for new formal solutions to some of the most famous designers in the contemporary scene. This is how lamps uniquely styled creations designed to show its beauty in classy interior.*

*Zonca offers a full range of products and services to meet the needs Hotel class: the creations Zonca give light and elegance in accommodation facilities of the highest standard.*

*A success due to the ability to create customized products, in close co-operation between the company and the designers, the architects chosen by the client.*

*To all this, add a well-kept after-sales service, which is why these developments in detail meet any aesthetic requirement and technical adhering to the expectations of the most demanding.*



*In addition to its own in-house designers, the company relies on the search for new formal solutions to some of the most famous designers in the contemporary scene. This is how lamps uniquely styled creations designed to show its beauty in classy interior.*

*Bubbles and bumps in Venetian glass art, seams and joints in shades, slight color variations on different supplies, they are all possible imperfections in our products, created so uniquely crafted and in the tradition of made in Italy.*

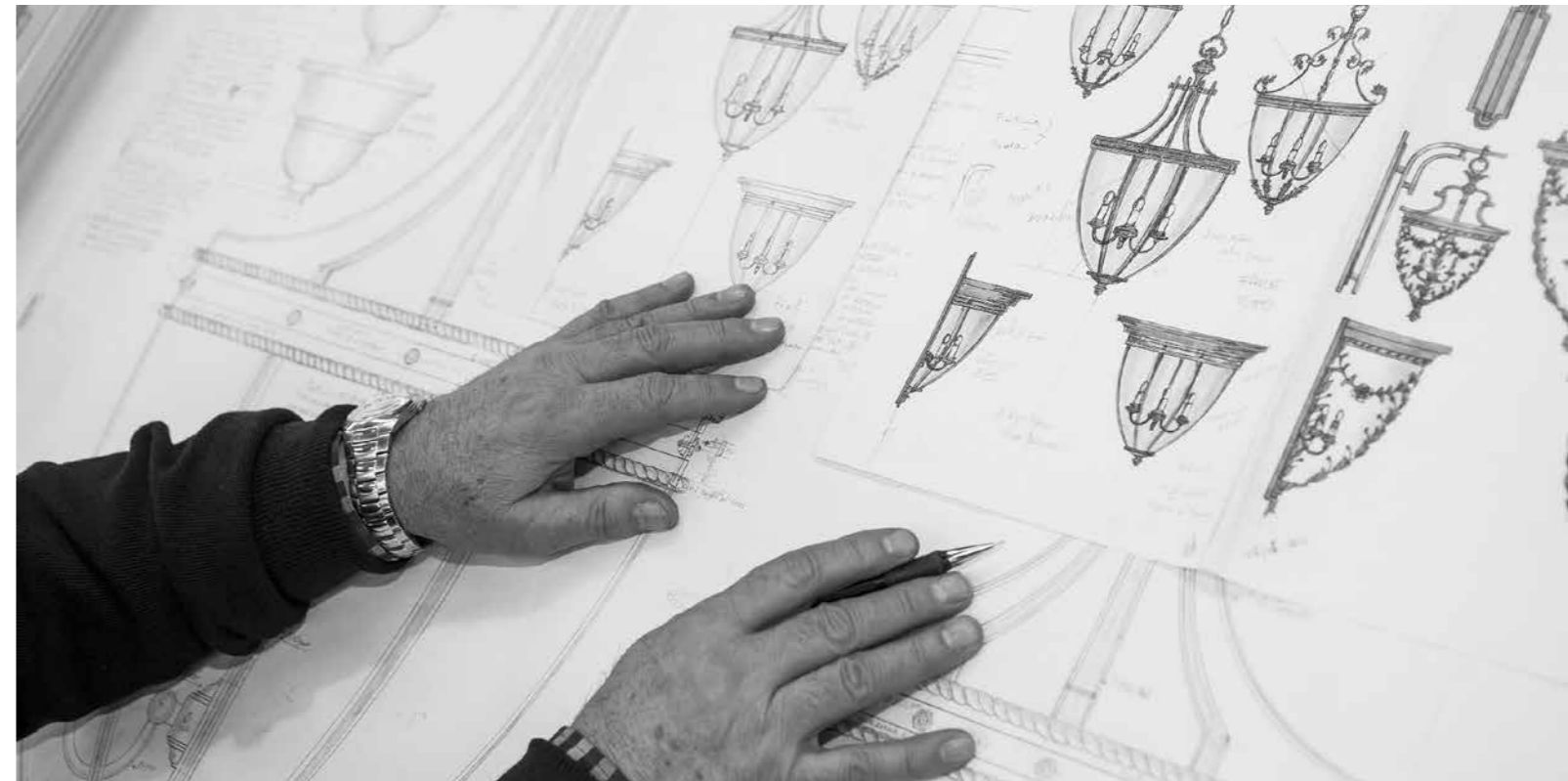



# CONTRACT

HOTEL

BAR

RESIDENCE

PRIVATE VILLA

OFFICE

BOUTIQUE

## LA RESERVE RAMATUELLE

A pochi minuti da Saint-Tropez, la Réserve Ramatuelle si affaccia su una delle baie più belle della Costa Azzurra, con una spettacolare vista sul mare ed una vasta tenuta privata immersa nella macchia provenzale. I toni delicati dell'azzurro, del blu e del bianco, caratterizzano la Réserve che Zonca Lighting, in collaborazione con l'interior designer Jacques Garcia, ha abilmente illuminato creando scultoree installazioni che incorniciano alla perfezione il ristorante due stelle Michelin La Voile, la lounge e la terrazza sul mare. Il risultato è una splendida location dove si respira un'atmosfera da sogno.

*A few minutes from Saint-Tropez, the Réserve Ramatuelle overlooks one of the most beautiful bays of the Côte d'Azur, with a spectacular view of the sea and a large private estate surrounded by the Provençal maquis. The delicate tones of lightblue, blue and white, characterize the Réserve that Zonca Lighting, in collaboration with interior designer Jacques Garcia, has cleverly illuminated creating sculptural installations that perfectly frame the two Michelin Stars restaurant, La Voile,, the lounge and the terrace overlooking the sea. The result is a wonderful location where you can breathe a dream atmosphere.*



## THE PEARL HOTEL MARRAKECH



Situato nel cuore di una città vibrante e magica, The Pearl Hotel trasmette tutto il mistero e l'esotismo di un altro mondo: il luogo ideale per una fuga dalla realtà. Gli ambienti e l'atmosfera chic portano l'inconfondibile firma dell'architetto francese Jaques Garcia: qui vivono e convivono armoniosamente una varietà di stili che combinano il classico con l'etnico, il sontuoso e l'inebriante. Questo moderno boutique hotel a cinque stelle dispone di 71 camere, un favoloso centro termale sotterraneo e una vista invidiabile su Koutoubia dalla terrazza panoramica. Il colore dominante è il viola, una tonalità che Zonca Lighting ha illuminato avvolgendo di atmosfera le sete drappeggiate e i tessuti vellutati ricreando una versione moderna dello stile marocchino. Un'elaborazione che Zonca Lighting ha sviluppato instaurando una relazione davvero speciale fra il confort e l'arte dell'ospitalità.

*Located in the heart of a vibrant and magical city, The Pearl transmits all the mystery and exoticism of another world: it is the ideal place for an escape from reality. The rooms and the chic atmosphere bear the unmistakable signature of French architect Jacques Garcia. Here, a variety of styles, that integrate the classic with the ethnic and the sumptuous with the inebriating, coexist in complete harmony. This modern five-star boutique hotel has 71 rooms, a fabulous underground spa and an enviable view of Koutoubia from the rooftop terrace. The dominant colour is purple, a shade that Zonca Lighting has illuminated enveloping atmosphere the draped silks and velvety fabrics, thus recreating a modern version of the Moroccan style. An elaboration that Zonca Lighting developed by establishing a very special relationship between comfort and the art of hospitality.*



## L'OSCAR HOTEL LONDON

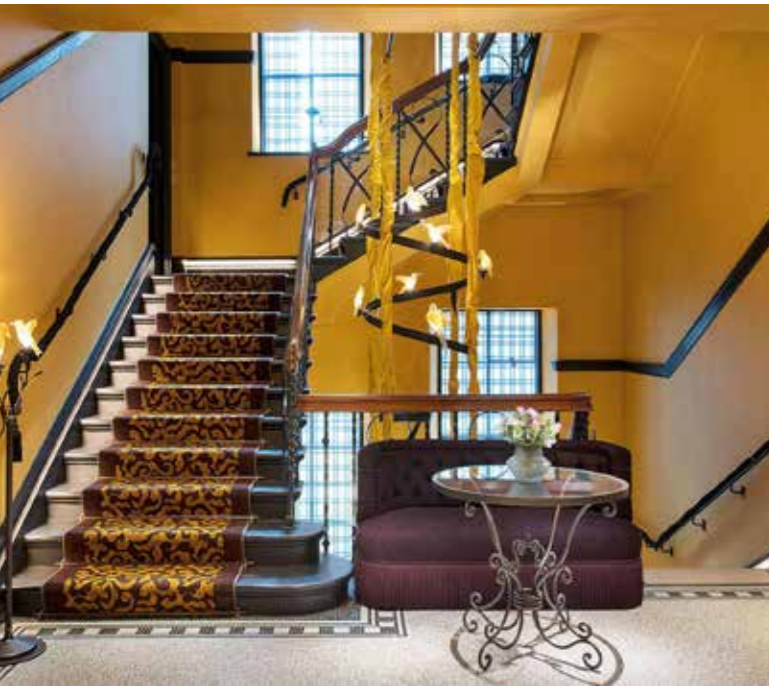

L'Oscar Hotel Londra è un lussuoso boutique hotel 5 stelle, ricavato da un'ex chiesa di Bloomsbury nel quartiere di Holborn, che rende omaggio nel nome e nello stile allo scrittore irlandese Oscar Wilde. L'edificio storico risale agli inizi del XX secolo ed è stato riscoperto, dall'attuale proprietario e dall'architetto Jacques Garcia quasi casualmente, mentre passeggiavano per Londra. Ognuna delle 39 camere è unica nel suo design eclettico. I tratti distintivi sono i motivi ricorrenti di uccellini, 500 in tutto il palazzo, che sovrastano le lampade e plafoniere realizzate su disegno da Zonca Lighting. Il più iconico e spettacolare è sicuramente il lampadario che percorre da cima a fondo tutti i sette piani dell'hotel con una serie infinita di colibrì, pappagalli e picchi in una scenografica spirale. Una visione che da sola vale il soggiorno in uno fra i più prestigiosi luxury hotel del panorama internazionale.

*L'Oscar Hotel is a luxurious 5-star boutique hotel, housed in a former Bloomsbury church in the Holborn district, that pays tribute in name and style to the Irish writer Oscar Wilde. The historical building dates back to the early twentieth century and was rediscovered, by the current owner and by the architect Jacques Garcia, who found it almost randomly, while walking around London. Each of the 39 rooms is unique in its eclectic, design. The identifying traits are the recurrent motifs of birds, 500 in the whole building, that perched on lamps and ceiling lights custom made by Zonca Lighting. The most iconic and spectacular is certainly the chandelier that runs from top to bottom all the seven floors of the hotel with an endless series of hummingbirds, parrots, and pivert in a spectacular spiral. A vision that alone is worth the stay in what is a candidate to be among the most prestigious luxury hotels on the international scene.*



## HOTEL MARIA CRISTINA SAN SEBASTIAN



L'Hotel Maria Cristina di San Sebastian rappresenta un'istituzione nel circuito dell'ospitalità dei Paesi Baschi. Fin dalla sua inaugurazione nel 1912, è rimasto strettamente legato alla storia, alle vicissitudini e alla vita culturale della città di San Sebastian. In occasione del centesimo anniversario dalla sua costruzione, la proprietà ha affidato allo studio HBA di Londra il progetto di restyling degli ambienti interni di questa meta cinque stelle lusso. A Zonca Lighting è stata affidata la realizzazione di pezzi unici su misura per conferire un'impronta classicheggiante, senza però rinunciare ad introdurre dettagli di design. Gli splendidi interni si ispirano alla Belle Époque e si distinguono per le maestose colonne, i ritratti ottocenteschi e gli spettacolari lampadari a bracci. L'insieme è sorprendentemente eclettico e i cristalli dei lampadari a soffitto e le sete dei paralumi alle pareti completano con un tocco di made in Italy l'atmosfera di questo prestigioso luxury hotel.



*The Maria Cristina Hotel in San Sebastian is an institution in the Basque country's hospitality circuit. Since its inauguration in 1912, it has remained closely bound to the history, vicissitudes and cultural life of the city of San Sebastian. For its one hundredth anniversary, the property entrusted the HBA in London with the project of restyling the interiors of this five-star luxury hotel. Zonca Lighting was entrusted with the creation of unique tailored pieces so as to furnish the hotel with a classic style, without renouncing the introduction of design details. The beautiful interiors are inspired by the Belle Époque and stand out for their majestic columns, nineteenth-century portraits, refined silk brocades and the spectacular armed chandeliers. The decor is surprisingly eclectic and the crystals of the ceiling chandeliers and the silks of the lampshades on the walls complete the atmosphere of this prestigious luxury hotel with a 'Made in Italy' touch.*



## HOTEL DANIELI VENEZIA



Affascinante e lussuoso Hotel Danieli Venezia si trova in una delle posizioni più esclusive della città. L'interno è riccamente decorato con lampadari in vetro artigianale, preziosi tessuti e tappezzerie, colonne in marmo lavorate a mano e un sublime arredamento d'epoca. Il Danieli è l'apoteosi della Venezia più esotica, aristocratica ed esclusiva che si possa immaginare e, non a caso, è considerato fra i top 20 hotel più iconici al mondo. Zonca Lighting, in collaborazione con l'interior designer Jacques Garcia, ha illuminato le camere personalizzando ogni dettaglio e ricreando una storica atmosfera. È firmata Zonca Lighting anche l'illuminazione delle storiche suites progettate dall'architetto Pierre Yves Rochon. Le luci soffuse e i paralumi in sintonia con i velluti dell'arredamento, creano una cornice assolutamente romantica, elegante e raffinata.

*Charming and luxurious, Hotel Danieli Venice is located in one of the most exclusive locations in the city. The interior is richly decorated with artisan glass chandeliers, precious fabrics and tapestries, hand-crafted marble columns and a sublime period decor. Hotel Danieli Venice is the apotheosis of the most exotic, aristocratic and exclusive Venice imaginable, it's no coincidence that it is considered among the top 20 most iconic hotels in the world. Zonca Lighting, in partnership with the interior designer Jacques Garcia, illuminated the hotel's rooms, customizing every detail and recreating a historic atmosphere. The lighting of the historic suites, designed by the architect Pierre Yves Rochon, is also signed by Zonca Lighting. Soft lights and lampshades, in line with the velvet on the furnishings, create a particularly romantic, elegant and refined setting.*



## GRAND HOTEL TREMEZZO COMO



Sulle suggestive rive del Lago di Como sorge il Grand Hotel Tremezzo, uno degli alberghi di lusso più belli e più antichi della zona. Unico ed esclusivo, il Grand Hotel Tremezzo nasconde al suo interno gioielli preziosi: camere raffinate, suite panoramiche e suite storiche. Zonca Lighting ha curato i dettagli e l'illuminazione della Suite Emilia. Situata nell'adiacente Villa Emilia, storico edificio del '700, è connotata da colori delicati nei toni del verde, azzurro e grigio ed offre privacy assoluta per un soggiorno davvero romantico. Zonca Lighting ha scelto un'atmosfera di luce soffusa realizzata con le creazioni delle iconiche collezioni "Milano", "Ballerina" ed "Alfred", quest'ultima firmata Jacques Garcia. Un tocco di pura poesia per una location indimenticabile che ha anche accesso privato e diretto alla scenografica T Spa, dove l'illuminazione è nuovamente firmata Zonca Lighting.



*On the suggestive rivers of Lake of Como stands the Grand Hotel Tremezzo, one of the most beautiful and oldest luxury hotels in the area. Unique and exclusive, The Grand Hotel Tremezzo hides precious jewels: refined rooms, panoramic suites and historic suites. Zonca Lighting took care of the details and the lighting of the Emilia Suite. Located in the adjacent Villa Emilia, a historic eighteenth century building, it is characterized by delicate colours in shades of green, blue and offers absolute privacy, for a truly romantic stay. Zonca Lighting chose a soft light atmosphere with the creations of the iconic collections "Milano", "Ballerina" and "Alfred", the last one signed by Jacques Garcia. A touch of pure poetry for an unforgettable location that also has private and direct access to the scenic T Spa, where the lighting is once again signed Zonca Lighting.*



## EXCELSIOR HOTEL GALLIA MILANO

Il Complesso dell'Excelsior Hotel Gallia Milano, su progetto di architettura e interior design dell'Architetto Marco Piva, è tornato ad essere parte integrante di Piazza Duca D'Aosta. L'hotel oggi, seguendo la sua quasi centenaria tradizione, si configura come una "macchina ricettiva" tra le più avanzate al mondo. Protagonista è il progetto della luce realizzato da Zonca Lighting, che ha installato migliaia di sorgenti luminose, molti delle quali su misura, come le lampade "Meneghina" e "X". "X", ad esempio, è ispirata alle losanghe che caratterizzano gli intradossi delle logge dell'antico edificio e posizionate ad incasso in diverse aree della struttura, dai piani scala agli ascensori. "Meneghina" invece proietta giochi di luce nello spazio attraverso tagli lineari, impreziosendo la "Promenade" interna di quasi 100 metri che collega gli spazi comuni dell'ala storica alla Grande Hall del nuovo edificio, donando all'ambiente un'immagine unica.

*The Excelsior Hotel Gallia Milan returned to being an integral part of Piazza Duca D'Aosta following the architectural and interior design project by architect Marco Piva. Today the hotel, with its nearly 100-year tradition, is considered as one of the most advanced "receptive machines" in the world. Protagonist is the lighting project realized by Zonca Lighting, that has installed thousands of light sources, many of which were custom made, such as the "Meneghina" and "X" lamps. "X", for example, is inspired by the lozenges that characterize the intrados of the ancient building's loggias and embedded in various areas throughout the structure, from the staircase to the elevators. "Meneghina", on the other hand, projects a play of light in space through linear cuts, embellishing the 100 meter internal "Promenade" which connects the common spaces of the historical wing to the new building's Grand Hall, giving to the environment a unique image.*





## HOTEL SELMAN MARRAKECH

Superbo, elegante, armonioso e di classe: il Selman Hotel Marrakech è un luogo di fine ospitalità a cinque stelle, affacciato sulle montagne dell'Atlante e aperto alla magia inebriante di Marrakech. Inconfondibile è il tocco dell'architetto francese Jacques Garcia, che per questo luogo ha concepito un'atmosfera lontana dagli standard internazionali, che coniuga la visione artistica e lo stile moresco del Nord Africa con la passione per i cavalli del proprietario. Ogni angolo di questo particolarissimo luxury hotel mostra richiami e dettagli del mondo equestre, grandi lampadari, sinuose chaises longue, tappezzeria viola e oro antico imperiale si susseguono nel disegno di stile che attinge alla cultura e arte araba. In un contesto così particolare Zonca Lighting ha inserito un classico della collezione Jacques Garcia: "Alfred", la lampada da terra con rifinitura in bronzo dorato e il paralume color avorio, illumina in modo soffuso le aree comuni di questo prezioso boutique hotel.

*Superb, elegant, harmonious and classy: the Selman Hotel Marrakech is a refined five-star hospitality location, overlooking the Atlas mountains and the intoxicating magic of Marrakech. Unmistakable is the touch of the French architect Jacques Garcia, who conceived an atmosphere far from international standards that combines artistic vision and the North African Moorish style with the passion for the owners' horses. Every corner of this incredibly particular luxury hotel depicts references and details of the equestrian world, large chandeliers, sinuous chaises longues, purple upholstery and imperial antique gold follow each other in style design that draws on Arabic culture and art. In such a particular context, Zonca Lighting chose to include a classic from the Jacques Garcia collection: "Alfred", the floor lamp with gilt bronze finish and ivory lampshade, a floor lamp that illuminates the common areas of this precious boutique hotel with a suffusing light.*



## BOUTIQUE NANUSHKA LONDON

A Mayfair, uno dei più esclusivi quartieri di Londra, dove regnano haute couture, ristoranti stellati e un'animata vita notturna, si trova l'iconica Boutique Nanushka. Il marchio Nanushka nasce nel 2006, dal talento della fashion designer Sandra Sandor in collaborazione con Peter Baldaszti. Un brand che trae ispirazione dal viaggio spirituale attraverso le culture e il tempo, con uno stile inconfondibile di disinvolta e sottile femminilità. Per la boutique di 30 Bruton St Zonca Lighting, su progetto di Charlotte de Tonnac e Hugo Sauzay di Festen Architecture, ha creato particolari corpi illuminanti interamente tailor-made. Realizzati in vetro soffiato artigianale color avorio e sostenuti da esili strutture in ottone, esaltano il design moderno del flagship store londinese.

*In Mayfair, one of the most exclusive districts of London, where haute couture, starry restaurants and a lively nightlife reign, you will find the iconic Nanushka Boutique. The Nanushka brand was founded in 2006 by the talent of fashion designer Sandra Sandor in collaboration with Peter Baldaszti. A brand that draws inspiration from the spiritual journey through cultures and time, with an unmistakable style of casual and subtle femininity. For the 30 Bruton St boutique Zonca Lighting, on a design by Charlotte de Tonnac and Hugo Sauzay of Festen Architecture, has created special lighting fixtures entirely tailor-made. Crafted in ivory blown glass and supported by slender brass structures, they enhance the modern design of the London flagship store.*



## HOTEL CHATEAU MONFORT MILANO



Interamente ispirato al concept delle fairy tales, Château Monfort Milano ha inaugurato un'inedita tipologia, quella dell'Urban Château, ovvero un contesto caratterizzato da una forte identità, fantasia ed immaginazione. È il frutto di una lunga progettazione ad opera delle scenografe Elisabetta Frazuoli e Francesca Fezzi di FZI Interiors insieme all'architetto Sofia Vedani, proprietaria dell'hotel. Un restauro silenzioso e rispettoso, della struttura originaria che ha coinvolto Zonca Lighting nella delicata fase dell'illuminazione. Le progettiste hanno scelto di caratterizzare la luce dell'ingresso utilizzando dei lampioni, per evocare le atmosfere di un tempo, e Zonca Lighting ha esaudito il desiderio riproducendo lo stile originale delle lampade per illuminare l'intera struttura dalla pensilina liberty alla lobby, dalle suites alla sala meeting nelle antiche segrete del palazzo. Niente è stato tralasciato a Château Monfort.

*Entirely inspired by the concept of fairy tales, Chateau Monfort inaugurated an original typology: the Urban Château, or rather a context characterized by strong identity, fantasy and imagination. It is the result of a long design by the two set design Elisabetta Frazuoli and Francesca Fezzi of FZI Interiors along with the architect Sofia Vedani, hotel owner. A silent and respectful restoration work of the original structure which involved Zonca Lighting in the delicate phase of lighting. The designers chose to characterize the light of the entrance using street lamps so as to evoke an atmosphere from the past and Zonca Lighting fulfilled their request by reproducing the original style of the lamps to illuminate the whole structure from the Art Nouveau entrance to the lobby, from the suites to the meeting room in the ancient dungeons of the palace. Nothing has been left out in Château Monfort.*

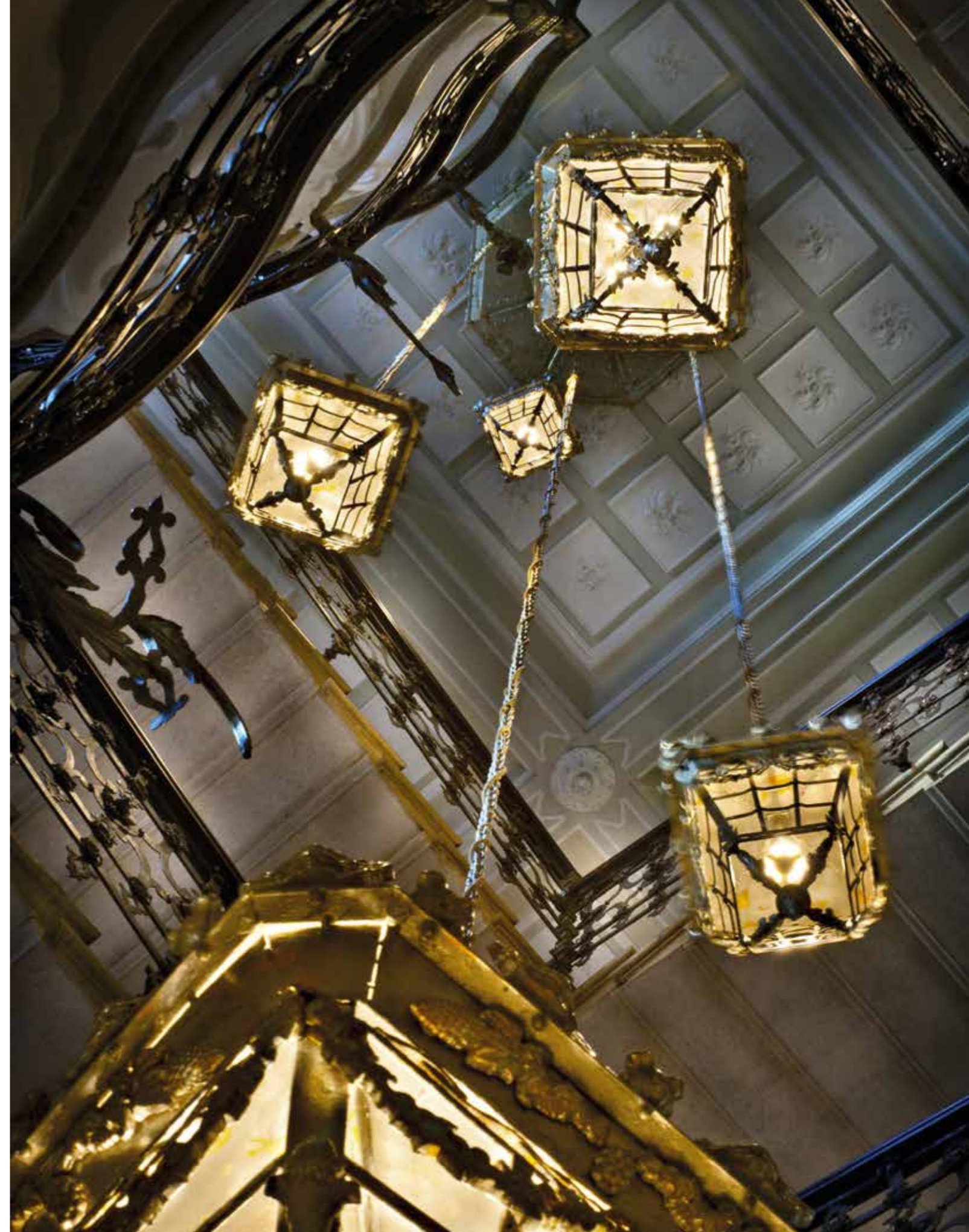

## LA RESERVE HOTEL PARIS



L'hotel si trova al 42 di Avenue Gabriel in una villa Haussmann tra Avenue Montaigne e rue Faubourg Saint Honoré con splendidi spazi esterni e vista sulla Torre Eiffel. L'imprenditore francese Michel Reybier ha scelto l'architetto Jacques Garcia, per conferire un tocco unico alla sua ultima creatura sugli Champs-Élysées. Gli spazi interni sono arredati con mobili antichi, carta da parati damascata e tappezzeria di velluto. Ognuna delle 40 camere appaiono come un piccolo scrigno di colori e tinte oro. I riflessi degli specchi enfatizzano la luce naturale ma anche il gioco di illuminazione realizzato da Zonca Lighting, appositamente per questa struttura, creando soluzioni su misura in ogni ambiente. Oltre a un lussuoso centro benessere con piscina coperta, l'hotel ospita una biblioteca e un ristorante francese contemporaneo, Le Gabriel, due stelle Michelin.



*L' Hotel is located at 42 Avenue Gabriel in a Haussmann villa between Avenue Montaigne and rue Faubourg Saint Honoré with beautiful outdoor spaces and a view of the Eiffel Tower. The French entrepreneur Michel Reybier chose the designer Jacques Garcia so as to give unique touch to his latest creation on the Champs-Élysées. The interiors are decorated with antique furniture, damask wallpaper and velvet upholstery. Each of the 40 rooms look like a small treasure chest with gold colours and shades. The reflections of the mirrors emphasize the natural light but also the play of light made by Zonca Lighting specifically for this structure, creating tailor-made solutions in every ambient. In addition to a luxurious spa with indoor pool, the hotel features a library and a contemporary French restaurant with two Michelin stars, Le Gabriel.*



## HOTEL EDEN ROMA



Collocato in una posizione invidiabile, tra Piazza di Spagna, Villa Borghese e Via Veneto, l'hotel Eden Roma è considerato il top dell'accoglienza di lusso della Capitale dal 1889. È stato frequentato sin dall'apertura da reali, diplomatici e celebrità, quali Re Alfonso XIII di Spagna, Umberto di Savoia e Federico Fellini che qui, in piena Dolce Vita, amava rilasciare le interviste internazionali, circondato da una spettacolare vista sul centro di Roma. L'ambientazione dell'Hotel Eden Roma va oltre le cinque stelle e il restyling, firmato dagli architetti francesi Bruno Moinard & Claire Bétaille dell'agenzia 4BI & Associées, ha puntato tutto sull'italianità degli spazi e dei colori. Il tocco di Zonca Lighting, che ha curato l'illuminazione delle suites, si percepisce nell'atmosfera che ricrea un'aurea antica intrecciata ai gusti contemporanei. Negli interni, marmi bianchi, carte da parati in tessuto, vetri di Murano, tutto declinato in oro, nero, grigio con tocchi di rosso e verde, ogni intervento è stato realizzato con materiali esclusivi.

*Located in an enviable position, between Piazza di Spagna, Villa Borghese and Via Veneto, the Hotel Eden Rome is considered the best of luxury hospitality in the capital, it dates back to 1889. Since the moment it opened, was visited by royalty, diplomats and celebrities like the King Alfonso XIII of Spain, Umberto of Savoy and Federico Fellini who here, in the middle of Dolce Vita, loved to give international interviews, surrounded by a spectacular view of the center of Rome. The setting goes beyond 5-star and the meticulous restyling designed by the French architects, Bruno Moinard & Claire Bétaille of 4BI & Associées agency, focused everything on the Italian-ness of the spaces and colours. The touch by Zonca Lighting, who oversaw the lighting of the suites, is perceived in the atmosphere that recreates an antique aura, intertwined with contemporary taste. In the interiors, white marble, fabric wallpaper, Murano glass, all in gold, black, grey with touches of red and green, each intervention has been done with exclusive materials.*



## THE NOMAD HOTELS



Mathilde, Violetta, Diderot: i classici della collezione Zonca Lighting, impreziosiscono le stanze e gli spazi dei The NoMad Hotel a New York, Los Angeles e Las Vegas. In questi luxury hotels lo stile Jacques Garcia traspira da ogni dettaglio, ogni camera è arredata con mobili personalizzati, disegnati e decorati a mano, e con opere d'arte originali. Gli alti soffitti caratterizzano gli spazi comuni offrendo un luogo di ritrovo per cenare e socializzare in un'atmosfera enfatizzata dall'illuminazione firmata Zonca Lighting. In particolare la libreria del The NoMad hotel di New York è un gioco di arte, cultura e luci come in nessun altro luogo al mondo. Dalla lobby al ristorante, dalle sale da bagno alla biblioteca, i The NoMad Hotels sono una galleria d'arte e di sorprese dove le lampade Zonca Lighting, da terra e da parete, sono rese inconfondibili dai classici paralumi in tessuto pregiato.



*Mathilde, Violetta, Diderot: the most classic of the Zonca Lighting collection, embellish the rooms and spaces of The NoMad Hotels in New York, Los Angeles and Las Vegas. In these luxury hotels the Jacques Garcia style breathes through every detail, each room is furnished with custom furniture, designed and decorated by hand, and with original works of art. The high ceilings characterize the common areas offering a meeting place to dine and socialize in an atmosphere emphasized by the lighting signed Zonca Lighting. In particular, the library of The NoMad Hotel in New York is a game of art, culture and lights like nowhere else in the world. From the lobby to the restaurant, from the bathrooms to the library, The NoMad Hotels are an art and surprise gallery in which Zonca Lighting wall and floor lamps are made unmistakable by the classic lampshades in fine fabric.*



## THE ALPINA HOTEL GSTAAD

Inge Moore e Nathan Hutchins di Muza Lab hanno guidato il team di progettisti che ha lavorato al Grand Hotel The Alpina Gstaad, 5 stelle superior, collocato in uno scenario spettacolare nella località più glamour della Svizzera. Il design abbraccia la leggenda, ma al contempo sposa la modernità. La posizione offre uno straordinario legame con il mondo alpino esterno mentre la personalizzazione degli interni ricorda una residenza privata molto speciale. Per questa esclusiva destinazione, Zonca Lighting ha elaborato un progetto d'illuminazione capace di valorizzare ogni singolo dettaglio, per enfatizzare in modo univoco la raffinatezza dell'accoglienza svizzera. Un sofisticato gioco di luci che permea l'atmosfera tra materiali locali originali e contemporanei che delicatamente si accostano al legno d'epoca autentico.

*Inge Moore and Nathan Hutchins from Muza Lab led the design team that worked at the 5-star-superior Grand Hotel The Alpina Gstaad, set in spectacular scenery in the most glamorous location in Switzerland. Design embraces the legend, but at the same time embraces modernity and a generous array of idiosyncratic delights, offering an extraordinary connection with the Alpine world outside and, inside, the individuality reminiscent of a very special private residence. For this exclusive destination, Zonca Lighting has developed a lighting project able to enhance every single detail, to uniquely embody the sophistication of the Swiss hospitality. A sophisticated play of lights that permeates the atmosphere between original and contemporary local materials that delicately combine with authentic antique wood.*

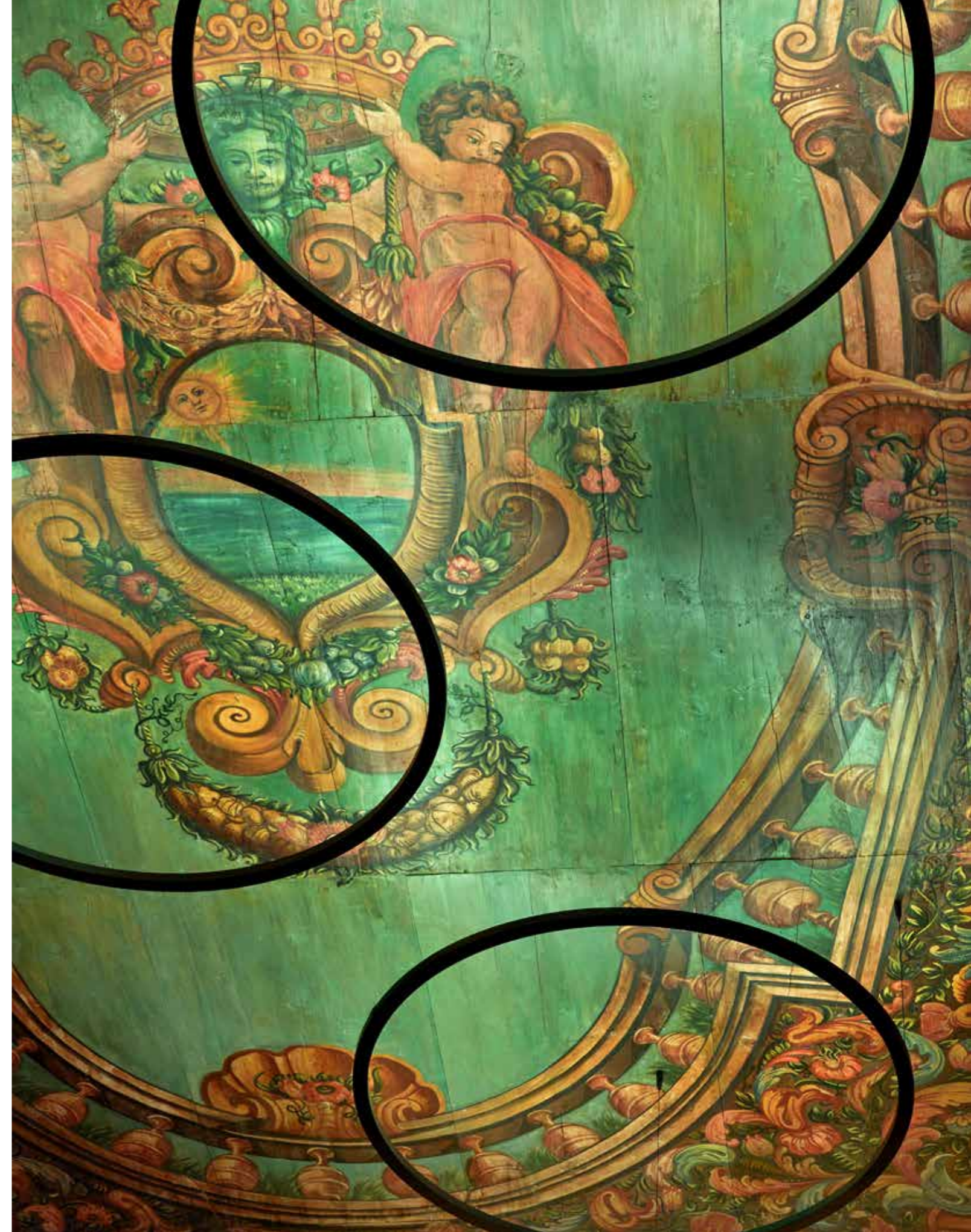

## CHÂTEAU DE FERRIÈRES



Straordinaria location per cerimonie ed eventi a Ferrières en Brie, in Francia, costruito nel XIX secolo dal ramo francese della famiglia Rothschild con ispirazione italiana e inglese, Château de Ferrières rappresenta uno dei gioielli del patrimonio architettonico del paese. Il famoso architetto Pierre-Yves Rochon ha scelto "Fiore", uno dei grandi classici della collezione Zonca Lighting, per arredare in modo originale e suggestivo la lounge del Château, mentre l'antica sala da biliardo della famiglia Rothschild è stata amabilmente decorata nei toni contrastanti del bianco e del blu. Per l'occasione "Fiore", lampadario in vetro trasparente e finitura in cromo, è stato realizzato nella tonalità del blu acceso, acquisendo un'eleganza aristocratica fuori dal comune. Ancora una volta Zonca Lighting ha dimostrato una minuziosa cura dei particolari, con l'innata capacità di rendere esclusivo ogni ambiente.



*An extraordinary location for ceremonies and events in Ferrières en Brie, France, built in the nineteenth century by the French side of the Rothschild family, through Italian and English inspiration, Château de Ferrières is one of the jewels of the country's architectural heritage. The famous architect Pierre-Yves Rochon has chosen "Fiore", one of the great classics of the Zonca Lighting collection, to furnish in an original and suggestive manner the lounge of the Château, while the old billiard room of the Rothschild family has been lovingly decorated in contrasting shades of white and blue. For the occasion, "Fiore", a transparent glass chandelier with chrome finish, was created in bright blue, acquiring an aristocratic elegance that can be considered out of the ordinary. Once again Zonca Lighting has shown meticulous attention to detail, with the innate ability to make any environment exclusive.*





## BIRAGHI STORE PIAZZA SAN CARLO - TORINO

Situato in Piazza San Carlo, nel salotto torinese, cuore storico e artistico della città, il Negozio Biraghi sorge nei locali storici dell'ex F.lli Paissa che già nel 1884 esercitava l'attività di fornitore della Real Casa. Nel 2019 Biraghi ha restaurato questi locali storici per diffondere e valorizzare le eccellenze enogastronomiche del Piemonte. Gli arredi, che risalgono a epoche significative in linea con la storicità del negozio e mantengono inalterati lo stile del palazzo e l'atmosfera della piazza, sono arricchiti dall'antica Farmacia Gambarova che già nel 1740, a Biella, esercitava il lavoro di speziale dell'allora Regno di Sardegna. Questo storico arredo, sottoposto a tutela storico-artistica da parte della Soprintendenza di Torino, grazie al restauro effettuato dalla Biraghi oggi può essere ammirato in centro a Torino. Zonca Lighting ha realizzato per il Negozio Biraghi sette lampadari in cristallo dal taglio classico che richiamano lo stile Ottocentesco, arricchendo l'ingresso e le sale del punto vendita, donando agli ambienti eleganza e luminosità.

*Located in Piazza San Carlo, in the Turin lounge, the historic and artistic heart of the city, the Biraghi Shop is located in the historic premises of the former F.lli Paissa who already in 1884 was a supplier of the Real Casa. In 2019 Biraghi has restored these historic places to spread and enhance the culinary excellence of Piedmont. The furnishing, which date back to significant periods in the line with the history of the shop and maintain the style of the palace and the atmosphere of the square, are enriched by the ancient pharmacy Gambarova that already in 1740, in Biella; he worked as an apothecary for the then Kingdom of Sardinia. Thanks to the restoration carried out by Biraghi, this historic piece of furniture, which has been subjected to historical and artistic protection by the Turin Superintendence, can now be admired in the centre of Turin. Zonca Lighting has created for the Biraghi Store seven chandeliers in crystal with a classic cut that recall the nineteenth-century style, enriching the entrance and the halls of the store, giving elegance and brightness to the environments.*



## SIX SENCES DUXTON HOTEL SINGAPORE



The Six Senses Duxton Hotel Singapore, nel distretto di Tanjong Pagar adiacente all'emergente Central Business District, è stato progettato trasformando i vecchi spazi commerciali del quartiere riportando alla luce le radici e l'essenza della Singapore più autentica. Questo magnifico boutique hotel dispone di 50 camere dislocate in otto edifici a tre piani, con un tema di colori che gioca sui toni del giallo e del nero, ricche influenze orientali e il senso del lusso e del glamour che si respira in ogni angolo. Zonca Lighting ha realizzato, per questo particolare progetto, una serie di lampade studiate su misura per calarsi in ogni dettaglio in un ambiente contaminato da numerose influenze artistiche e stilistiche. Una sfida in cui Zonca Lighting ha investito risorse ed energie e il cui risultato affascina lo sguardo di viaggiatori provenienti da tutto il mondo.



*The Six Senses Duxton Hotel Singapore, in the Tanjong Pagar district next to the emerging Central Business District, has been designed by transforming the old commercial spaces of the district bringing to light the roots and the essence of the most authentic Singapore. This beautiful boutique hotel has 50 rooms located in eight three-storey buildings, with the theme of colours that plays on shades of yellow and black, rich oriental influences and the sense of luxury and glamour that can be perceived in every corner. For this particular project, Zonca Lighting produced a series of lamps designed to fit in every detail in an ambience that is contaminated by numerous artistic and stylistic influences. A challenge in which Zonca Lighting has invested resources and energies and the final result now fascinates travellers from all over the world.*



## DONOVAN BAR LONDON

Elegante, intimo e sofisticato, il Donovan Bar di Londra si cela all'interno del Brown's Hotel, ad Albemarle Street, poco distante da Green Park e Hyde Park. Per creare il gioco di luci perfetto, Zonca Lighting ha dovuto compiere un approfondito studio dell'ambiente: il locale, infatti, è di quelli storici londinesi, in cui è importante valorizzare con sensibilità gli elementi autentici, e Zonca Lighting ha saputo creare un'illuminazione soft e ricercata in sintonia con l'arredamento e le note jazz che accompagnano le serate. Il Donovan Bar è ispirato al nome del grande fotografo Terence Donovan le cui iconiche stampe in bianco e nero sono, insieme ai cocktail, la grande attrazione del locale. Al bancone del Donovan Bar, ai suoi tavoli accanto alla vetrata originale di San Giorgio del XIX secolo, si sono accomodati nel tempo personaggi come Charles Dickens, Winston Churchill e Alexander Graham Bell, il creatore del primo telefono al mondo. L'ampia gamma di vini, champagne e cocktail è servita con un tocco di stile glamour, non a caso ci troviamo in uno dei bar più alla moda di Londra.

*Elegant, intimate and sophisticated, the Donovan Bar in London is located inside the Brown's Hotel, on Albemarle Street, not far from Green Park and Hyde Park. In order to create the perfect play of light, Zonca Lighting had to carry out an in-depth study of the ambience: in fact, the Donovan Bar is one of the historical London locales and it was thus quite important to enhance the authentic elements with sensitivity and Zonca Lighting has created hence soft and refined lighting in line with the furniture and the jazz notes that accompany the evenings. The Donovan Bar is inspired by the name of the great photographer Terence Donovan whose iconic black and white prints are, along with cocktails, the great attraction of the local. Over time, people like Charles Dickens, Winston Churchill and Alexander Graham Bell, creator of the first phone in the world, sat at its counter and tables next to the original, nineteenth century St. George stained glass window. The wide range of wines, champagne and cocktails is served with a touch of glamour; it's not by chance that we find ourselves in one of the most fashionable bars in London.*



## BUDDHA BAR



Da sempre il Buddha Bar Montecarlo più che un lussuoso locale è simbolo di uno stile di vita. Ricavato dall'edificio di un'antica sala da concerti, combina storia ed esotismo inserendosi armoniosamente nella zona casinò della città monegasca. Tra luci ambrate, atmosfera zen, arredi dalle risonanze asiatiche, ed un Buddha gigante a dominare la scena, il Buddha Bar si caratterizza per uno stile fusion assolutamente unico. Da Parigi a Mosca, da San Pietroburgo a Manila, in ogni Buddha Bar realizzato si riconosce il tocco di Zonca Lighting, che ha curato l'illuminazione come parte integrante di una scenografia sorprendente. Ottone, oro, cristalli, tessuti pregiati: per le lampade da tavolo, le lampade da terra e le sospensioni realizzate su misura, Zonca Lighting ha impiegato i migliori materiali per arricchire di una veste sublime un interior design dal gusto raffinato.



*Since ever MonteCarlo's Buddha Bar is more than just a luxurious place, it's a lifestyle symbol. Created from an ancient concert hall building, it combines history and exoticism by blending harmoniously into the Monegasque city's casino area. Monaco's Buddha Bar, with its amber lights, Zen atmosphere, Asian-inspired furniture and a giant Buddha dominating the scene, is characterized by an absolutely unique fusion style. From Paris to Moscow, from Saint Petersburg to Manila, in every Buddha Bar realized Zonca Lighting's touch is clearly recognizable and it created lighting as an integral part of a surprising scenic design. Brass, gold, crystal, precious fabrics: Zonca Lighting used the best materials for tailor-made table, floor and ceiling lamps, to enrich a sublime look with a refined interior design.*

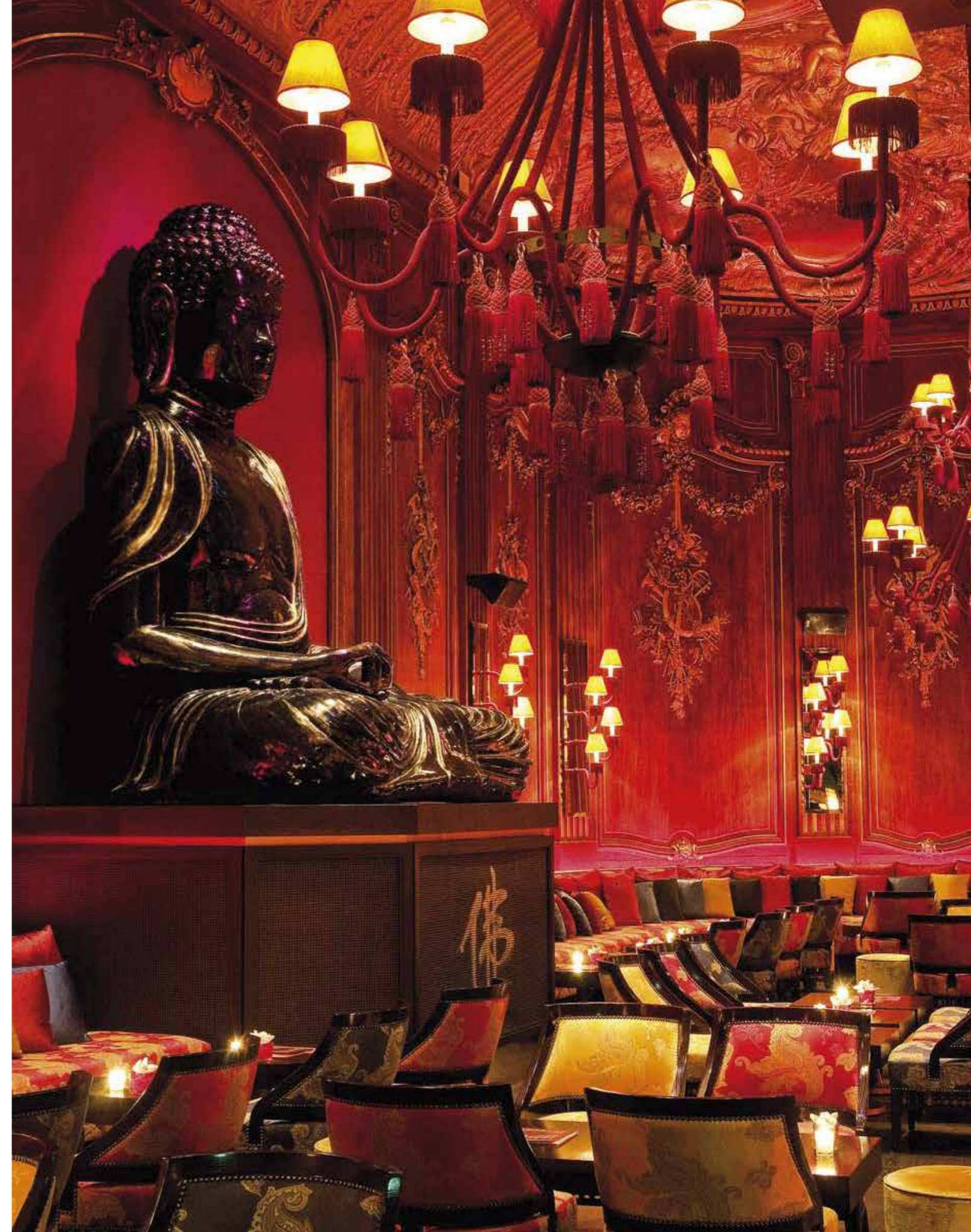

## HÔTEL BARRIÈRE LE FOUQUET'S PARIS

Negli anni '30 Le Fouquet's, famoso ristorante degli Champs-Élysées, era un luogo frequentato da star, registi, personalità di spicco e artisti. Successivamente la struttura è stata ampliata inglobando i lussuosi edifici adiacenti e dando così vita all'Hotel Barrière Le Fouquet. Per il progetto sono stati incaricati l'architetto Edouard François e il designer parigino Jacques Garcia nuovamente coinvolto, dieci anni dopo, per una seconda opera di ristrutturazione, ispirata alla ricca eredità dell'industria cinematografica francese. Per questo prestigioso progetto Zonca Lighting ha elaborato numerose soluzioni tailor-made oltre ad aver selezionato, fornito ed installato lampade e lampadari della collezione "Les Grands Classiques de Jacques Garcia", opera del designer parigino e prodotta in esclusiva da Zonca Lighting. In posizione privilegiata – VIII Arrondissement, nel cuore della rive droite – e icona architettonica e tecnologica, l'Hotel Barrière Le Fouquet è la location di lusso per un'esperienza autenticamente parigina.

*In the 1930s Hotel Barrière Le Fouquet's, the Champs-Élysées' famous restaurant, was a place frequented by stars, directors, prominent personalities and artists. Later the structure has been widened incorporating the luxurious adjacent buildings and thus giving life to the Hôtel Barrière Le Fouquet's. For the project were in charge the architect Edouard François and the Parisian designer Jacques Garcia involved once again, ten years later, for a second restructuring, inspired by the rich legacy of the French film industry. Zonca Lighting elaborated numerous tailor-made solutions for this prestigious project, as well as selecting, supplying and installing lamps and chandeliers from the "Les Grands Classiques de Jacques Garcia" collection, the work of the Parisian designer, which is produced exclusively by Zonca Lighting. Situated in a privileged position – VIII Arrondissement, in the heart of the 'rive droite' – and an architectural and technological icon, the Hotel Barrière Le Fouquet is the luxury location for an authentically Parisian experience.*



## MONSIEUR GEORGE PARIS



Situato sugli Champs-Élysées, con una vista spettacolare di Parigi, è un boutique hotel a 5 stelle di 46 camere dall'aura elegante. Gli interni sono caratterizzati da due tonalità cromatiche predominanti: il verde scuro e il nero nelle camere e nella lobby e il bianco puro, a totale contrasto, nelle suites. Zonca lighting ha realizzato per questo progetto particolari installazioni luminose interamente personalizzate e curate al dettaglio. Nel ristorante si innalzano sospensioni in vetro trasparente artigianale e dalla struttura tondeggiante, mentre le camere e le suites sono illuminate da appliques in ottone e da esili piantane in legno dal design minimal-chic. Il risultato è un ambiente esclusivo da cui traspare una sorprendente atmosfera di confort e intimità.



*Located on the Champs-Élysées, with spectacular view of Paris, this 5-star boutique hotel offers 46 rooms with a sensual and elegant aura. The interiors are characterized by two predominant chromatic shades: dark green and black in the rooms and lobby and pure white, totally at odds, in the suites. Zonca lighting has created for this project special lighting installations entirely customized and attention to detail. In the restaurant we find suspension in transparent glass craft and round structure, while the rooms and suites are illuminated by brass wall lamps and slender wooden floor units with minimal-chic design. The result is an exclusive environment, from which transpires a surprising atmosphere of comfort and intimacy.*





LES GRANDS CLASSIQUES  
DE JACQUES GARCIA

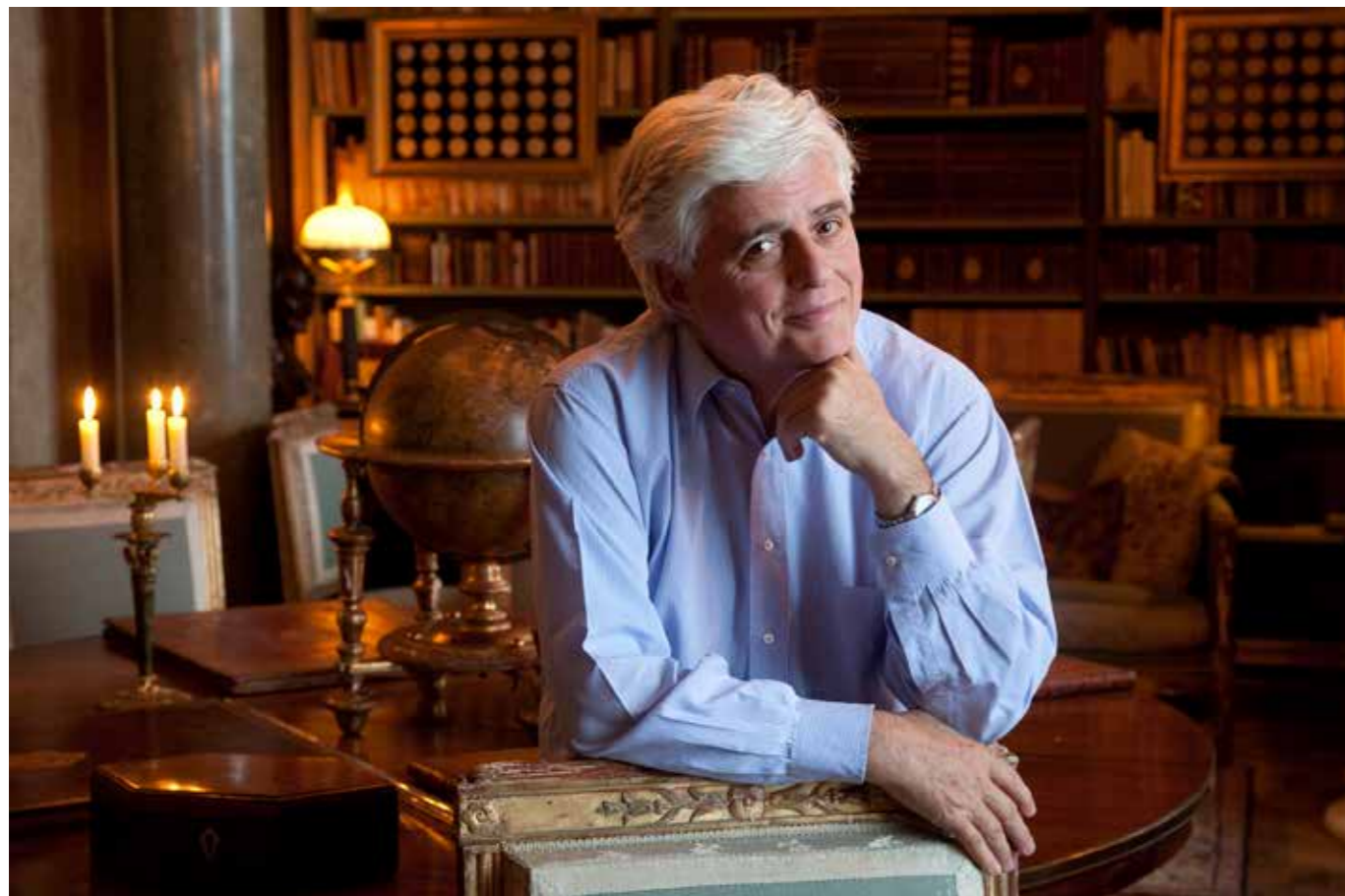

Architetto e decoratore rinomato, Jacques Garcia è diventato un punto di riferimento esclusivo al livello mondiale in materia di eleganza e raffinatezza. L'Hotel Costes di Parigi, il Metropole di Monte Carlo, l'Hotel Victor di Miami, la Mamounia di Marrakech o il Ritz di Parigi: i più grandi palazzi sposano la loro magnificenza alla sua avvolgente creatività. Indubbiamente, il successo unanime riscosso da ciascuno dei cinquanta luoghi decorati da Jaques Garcia ogni anno deriva dal rapporto estremamente particolare e personale che il decoratore intrattiene con la luce... proprio come un bell'oggetto, la giusta luce svela ai suoi occhi il segreto inestimabile di una vita migliore. Lottando con determinazione contro il grigiore che si è impadronito dei nostri interni contemporanei, la luce, per Jacques Garcia, è generosa, gioiosa, calda, festiva sensuale; tanti aggettivi che, a suo parere, incarnano la nozione di modernità. Indiscutibilmente, la luce lo ispira e conferisce a tutte le sue opere un'impronta caratteristica.

*Renowned architect and decorator, Jacques Garcia has become a world-class benchmark in terms of elegance and sophistication. The Hotel Costes in Paris, the Metropole in Monte Carlo, the Hotel Victor in Miami, the Mamounia in Marrakech or the Ritz in Paris: the largest buildings combine their magnificence with its enveloping creativity. Undoubtedly, the unanimous success of each of the fifty places decorated by Jaques Garcia each year derives from the extremely special and personal relationship that the decorator entertains with light... just like a beautiful object, the right light reveals to his eyes the inestimable secret of a better life. Struggling with determination against the greyness that has taken over our contemporary interiors, the light, for Jacques Garcia, is generous, joyful, warm, sensual festive; many adjectives that, in his opinion, embody the notion of modernity. Indisputably, light inspires him and gives all his works a characteristic imprint.*



VIOLETTA  
pag. 64



EGEO  
pag. 67



ULYSSE  
pag. 67



DECEBALE  
pag. 70



DELOS  
pag. 66



HECTOR  
pag. 66



ALFRED  
pag. 78



DIDEROT  
pag. 78



MATHILDE  
pag. 80



PILATE  
pag. 76



JANE  
pag. 76



VENUS  
pag. 68



RACINE  
pag. 72



BOILEAU  
pag. 72



MOLIERE  
pag. 74



GUSTAVE  
pag. 82



OH-LA-LÀ  
pag. 84



MONTMARTRE  
pag. 86



PELLEAS  
pag. 83

\* estratto dall'intera collezione - \* extract from entire collection





art. 30726

### VIOLETTA

Finition: *bronze doré* (135),  
*bronze vieil antiquaire* (136),  
*chrome* (102), *argent satiné* (164)

Abat-jour: *ivoire* (701), *noir* (704),  
*rouge théâtre* (707)

Dimension totale:  
W 6" H 12" D 8<sup>1/2</sup>"  
W 15 cm H 31 cm D 22 cm

Abat-jour/Shade/Paralumi  
Ø 6" ø 4<sup>1/2</sup>" H 4<sup>1/2</sup>"  
Ø 15 cm ø 12 cm H 12 cm

Ampoule : 1 E 14 28w





art. **30790**

### DELOS

Finition: *chrome (102)*

Abat-jour: *ivoire (701), noir (704),  
rouge théâtre (707)*

Dimension totale:  
W 6" H 21<sup>1/2</sup>" D 8"  
W 15 cm H 55 cm D 20 cm

Abat-jour/Shade/Paralumi  
Ø 6" ø 4<sup>1/2</sup>" H 4<sup>1/2</sup>"  
Ø 15 cm ø 12 cm H 12 cm

Ampoule : 1 E 14 42w



art. **30787**

### HECTOR

Finition: *chrome (102)*

Abat-jour: *ivoire (701), noir (704),  
rouge théâtre (707)*

Dimension totale:  
W 7<sup>1/2</sup>" H 18<sup>1/2</sup>" D 10"  
W 19 cm H 47 cm D 25 cm

Abat-jour/Shade/Paralumi  
Ø 7<sup>1/2</sup>" ø 5<sup>1/2</sup>" H 5<sup>1/2</sup>"  
Ø 19 cm ø 14 cm H 14 cm

Ampoule : 1 E 27 42w



art. **30789**

### EGEO

Finition: *chrome (102)*

Abat-jour: *ivoire (701), noir (704),  
rouge théâtre (707)*

Dimension totale:  
W 6" H 8" D 9"  
W 15 cm H 21 cm D 23 cm

Abat-jour/Shade/Paralumi  
Ø 7<sup>1/2</sup>" ø 5<sup>1/2</sup>" H 5<sup>1/2</sup>"  
Ø 15 cm ø 12 cm H 12 cm

Ampoule : 1 E 14 42w



art. **30791**

### ULYSSE

Finition: *chrome (102)*

Abat-jour: *ivoire (701), noir (704),  
rouge théâtre (707)*

Dimension totale:  
W 10" H 8<sup>1/2</sup>" D 8<sup>1/2</sup>"  
W 26 cm H 22 cm D 22 cm

Abat-jour/Shade/Paralumi  
Ø 6" ø 4<sup>1/2</sup>" H 4<sup>1/2</sup>"  
Ø 15 cm ø 12 cm H 12 cm

Ampoule : 1 E 14 42w

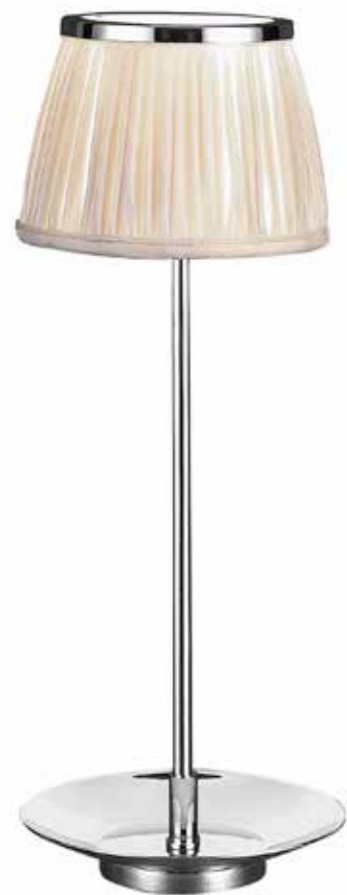

art. **30786**

### VENUS

Finition: *chrome (102)*

Abat-jour: *ivoire (701), noir (704),  
rouge théâtre (707)*

Dimension totale:  
W 7<sup>1/2</sup>" H 21"  
W 19 cm H 54 cm

Abat-jour/Shade/Paralumi  
Ø 7<sup>1/2</sup>" Ø 5<sup>1/2</sup>" H 5<sup>1/2</sup>"  
Ø 19 cm Ø 14 cm H 14 cm

Ampoule : 1 E 14 42w





art. **31344**

### DECEBALE

Finition: *bronze vieil antiquaire (136),  
argent satiné (164)*

Abat-jour: *ivoire (701), noir (704),  
rouge théâtre (707)*

Dimension totale:  
W 8" H 47" D 7<sup>1/2</sup>"  
W 20 cm H 120 cm D 19 cm

Abat-jour/Shade/Paralumi  
Ø 8" ø 4" H 9"  
Ø 20 cm ø 10 cm H 23 cm

Ampoule : 1 E 14 28w





art. 30716

**RACINE**

Finition: *bronze doré (135)*

Abat-jour: *rouge théâtre (707)*

Dimension totale:  
 W 12" H 16" D 20<sup>1/2</sup>"  
 W 30 cm H 41 cm D 51 cm

Abat-jour/Shade/Paralumi  
 Ø 12" ø 3" H 8<sup>1/2</sup>"  
 Ø 30 cm ø 7 cm H 22 cm

Ampoule : 1 E 27 42w



art. 30717

**BOILEAU**

Finition: *bronze doré (135)*

Abat-jour: *rouge théâtre (707)*

Dimension totale:  
 W 22<sup>1/2</sup>" H 16" D 20"  
 W 58 cm H 41 cm D 51 cm

Abat-jour/Shade/Paralumi  
 Ø 12" ø 3" H 8<sup>1/2</sup>"  
 Ø 30 cm ø 7 cm H 22 cm

Ampoule : 2 E 27 42w





art. 30734

MOLIERE

Finition: *bronze doré (135)*,

Abat-jour: *rouge théâtre (707)*

Dimension totale:

W 39<sup>1/2</sup>" H 46<sup>1/2</sup>"

W 100 cm H 118 cm

Abat-jour/Shade/Paralumi

Ø 39<sup>1/2</sup>" ø 12" H 33<sup>1/2</sup>"

Ø 100 cm ø 30 cm H 85 cm

Ampoule : 3 E 27 42w



art. 31350

PILATE

Finition: *argent satiné* (164)

Abat-jour: *ivoire* (701)

Dimension totale:  
W 16" x 16" H 56<sup>1/2</sup>"  
W 40 x 40 cm H 144 cm

Abat-jour/Shade/Paralumi  
W 16" x 16" w 11" x 11" H 10"  
W 40 x 40 cm w 28 x 28 cm H 25 cm

Ampoule : 1 E 27 70w



art. 31349

JANE

Finition: *argent satiné* (164)

Abat-jour: *ivoire* (701)

Dimension totale:  
W 14" x 14" H 26<sup>1/2</sup>"  
W 36 x 36 cm H 67 cm

Abat-jour/Shade/Paralumi  
W 14" x 14" w 10" x 10" H 8<sup>1/2</sup>"  
W 36 x 36 cm w 26 x 26 cm H 22 cm

Ampoule : 1 E 27 42w

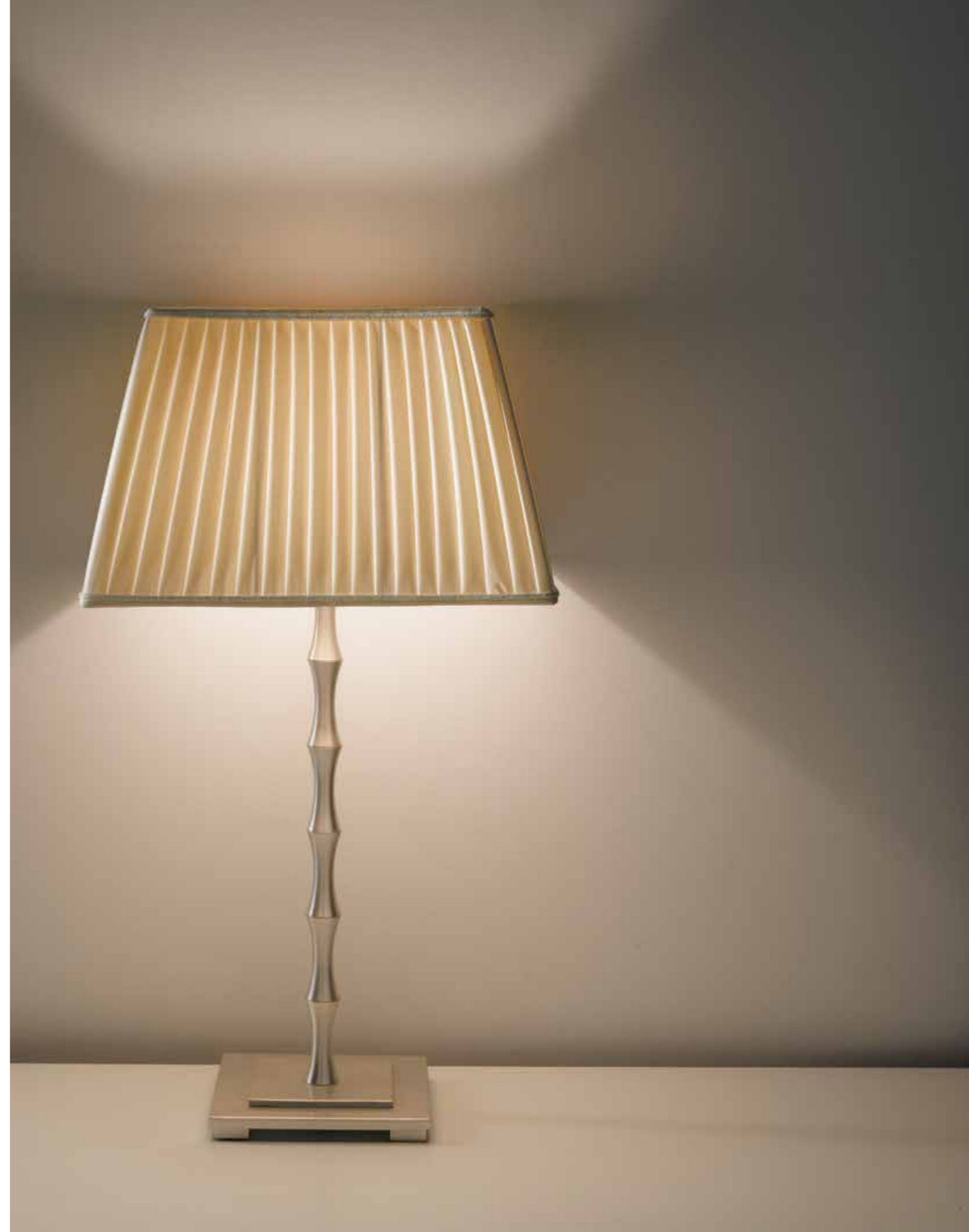

art. 30731

ALFRED

Finition: *bronze doré* (135),  
*chrome* (102)

Abat-jour: *ivoire* (701), *noir* (704)

Dimension totale:  
W 10" H 55<sup>1/2</sup>"  
W 25 cm H 140 cm

Abat-jour/Shade/Paralumi  
Ø 10" ø 3" H 8"  
Ø 25 cm ø 8 cm H 21 cm

Ampoule : 1 E 27 42w

art. 30729

DIDEROT

Finition: *bronze doré* (135),  
*chrome* (102)

Abat-jour: *ivoire* (701), *noir* (704)

Dimension totale:  
W 10" H 27" D 10"  
W 26 cm H 68 cm D 26 cm

Abat-jour/Shade/Paralumi  
Ø 10" ø 3" H 18"  
Ø 26 cm ø 8 cm H 21 cm

Ampoule : 1 E 27 42w







art. **30730**

### MATHILDE

Finition: *bronze doré* (135),  
*chrome* (102)

Abat-jour: *ivoire* (701), *noir* (704)

Dimension totale:

W 10" H 22<sup>1/2</sup>" D 20<sup>1/2</sup>"  
W 26 cm H 58 cm D 52 cm

Abat-jour/Shade/Paralumi  
Ø 10" ø 3" H 8"  
Ø 25 cm ø 8 cm H 21 cm

Ampoule : 1 E 27 42w





art. **31327**

### GUSTAVE

Finition: *bronze vieil antiquaire (136) -  
bout doré (135)*

Abat-jour: *ivoire (701)*

Dimension totale:  
W 67" x 23<sup>1/2</sup>" H 38"  
W 170 x 60 cm H 97 cm

Abat-jour/Shade/Paralumi  
Ø 23<sup>1/2</sup>" ø 14" H 14"  
Ø 60 cm ø 35 cm H 35 cm

Ampoule : 2 E 27 70w



art. **31363**

### PELLEAS

Finition: *bronze vieil antiquaire (136)*

Abat-jour: *ivoire (701)*

Dimension totale:  
W 14" H 32<sup>1/2</sup>"  
W 35 cm H 83 cm

Abat-jour/Shade/Paralumi  
Ø 14" H 18<sup>1/2</sup>"  
Ø 35 cm H 46,5 cm

Ampoule : 1 E 27 70w



art. 31333

### OH LA LÀ

Finition: *bronze doré (135),  
bronze vieil antiquaire (136),  
chrome (102), argent satiné (164)*

Dimension totale:

W 4" H 4" D 12<sup>1/2</sup>"  
W 10 cm H 10 cm D 34 cm

Ampoule : LED 1,4w 3000K



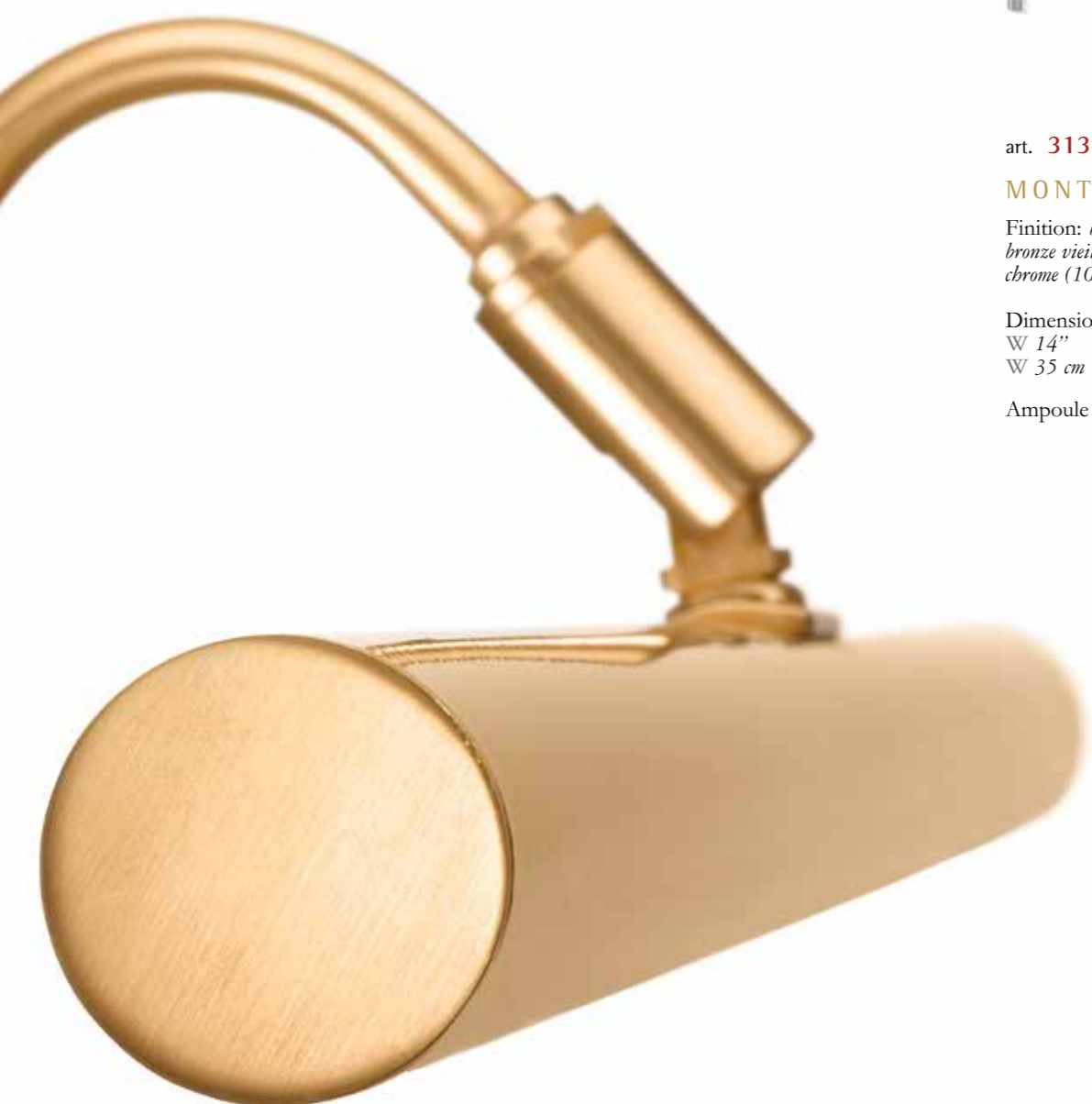

art. 31332  
**MONTMARTRE PM**  
Finition: *bronze doré (135),  
bronze vieil antiquaire (136),  
chrome (102), argent satiné (164)*  
Dimension totale:  
W 14" H 7" D 3 1/2"  
W 35 cm H 18 cm D 9 cm  
Ampoule : 2 G 9 20w



art. 31367  
**MONTMARTRE GM**  
Finition: *bronze doré (135),  
bronze vieil antiquaire (136),  
chrome (102), argent satiné (164)*  
Dimension totale:  
W 23 1/2" H 7" D 3 1/2"  
W 60 cm H 18 cm D 9 cm  
Ampoule : 2 G 9 20w

# PRODUCTS

HERITAGE

CLASSIC



















MODERN

CONTEMPORARY

















# INDICE ALFABETICO ALPHABETICAL INDEX

Nome prodotto Product name	pag. page
<u>Acqua</u>	172
<u>Amantide</u>	154
<u>Atmosfera</u>	162
<u>Ballerina</u>	188
<u>Barocca</u>	138
<u>Buggle</u>	176
<u>Chandelier</u>	152
<u>Classica</u>	124
<u>Dinamica</u>	175
<u>Doge</u>	94
<u>Fiore</u>	106
<u>Fluidi</u>	164
<u>Fluttuante</u>	166
<u>Giostra</u>	184
<u>Icona</u>	148
<u>Imperatrice</u>	100
<u>Lanterna</u>	140
<u>Mare</u>	142

Nome prodotto Product name	pag. page
<u>Milano</u>	180
<u>Monaco</u>	196
<u>Nightbook</u>	174
<u>Quadro</u>	178
<u>Rigore</u>	192
<u>Sboccia</u>	136
<u>Sempre</u>	168
<u>Settecento</u>	132
<u>Shock</u>	165
<u>Soffio</u>	110
<u>Sogni</u>	170
<u>Solitaria</u>	135
<u>Spring</u>	120
<u>Stellata</u>	144
<u>Sveva</u>	167
<u>Torre</u>	194
<u>Violante</u>	114
<u>Vola</u>	128

								
	Doge	94	Yellow	Grey	Yellow	Grey	Grey	Grey
	Imperatrice	100	Yellow	Grey	Yellow	Grey	Grey	Grey
	Fiore	106	Yellow	Grey	Yellow	Grey	Grey	Grey
	Soffio	110	Yellow	Grey	Yellow	Grey	Grey	Grey
	Violante	114	Yellow	Grey	Yellow	Grey	Grey	Grey
	Spring	120	Yellow	Grey	Grey	Grey	Grey	Grey
	Classica	124	Yellow	Grey	Yellow	Grey	Yellow	Yellow
	Vola	128	Yellow	Grey	Yellow	Yellow	Yellow	Yellow
	Settecento	132	Grey	Grey	Yellow	Grey	Grey	Grey
	Solitaria	135	Grey	Grey	Grey	Yellow	Grey	Grey
	Sboccia	136	Grey	Yellow	Grey	Grey	Grey	Grey
	Barocca	138	Grey	Yellow	Yellow	Grey	Grey	Grey

								
	Lanterna	140	Yellow		Yellow			
	Mare	142	Yellow	Yellow	Yellow			
	Stellata	144	Yellow		Yellow			
	Icona	148	Yellow	Yellow	Yellow			
	Chandelier	152	Yellow		Yellow			
	Amantide	154	Yellow		Yellow			
	Atmosfera	162				Yellow	Yellow	
	Fluidi	164	Yellow			Yellow		
	Shock	165				Yellow		
	Fluttuante	166				Yellow		
	Sveva	167				Yellow	Yellow	
	Sempre	168			Yellow	Yellow		Yellow

								
	Sogni	170			Yellow			
	Acqua	172		Yellow	Yellow			
	Nightbook	174			Yellow			
	Dinamica	175			Yellow			
	Buggle	176		Yellow	Yellow	Yellow		
	Quadro	178			Yellow			
	Milano	180			Yellow	Yellow	Yellow	Yellow
	Giostra	184	Yellow	Yellow				
	Ballerina	188	Yellow					
	Rigore	192			Yellow	Yellow		Yellow
	Torre	194	Yellow					
	Monaco	196				Yellow		Yellow



DOGE



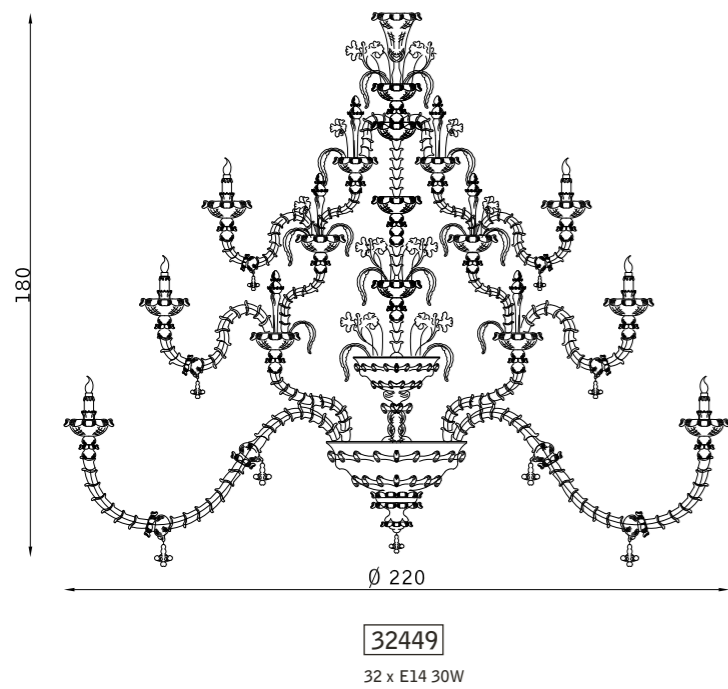
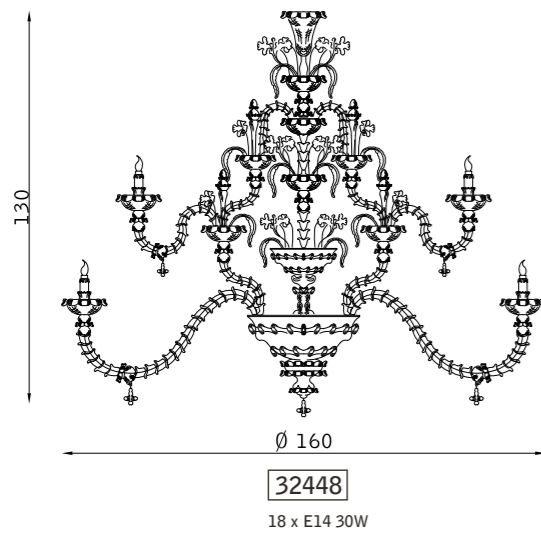
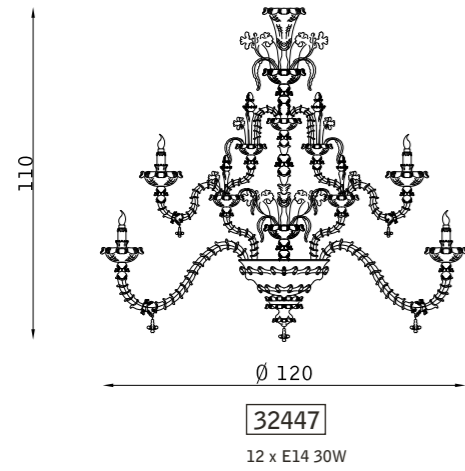

DOGE

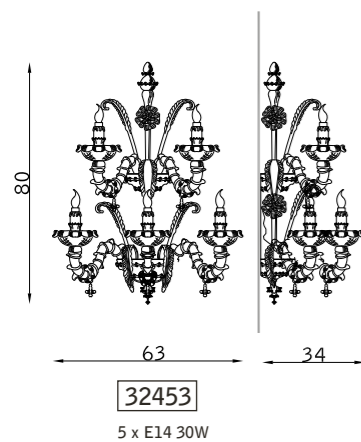
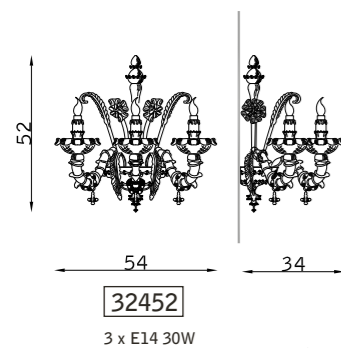
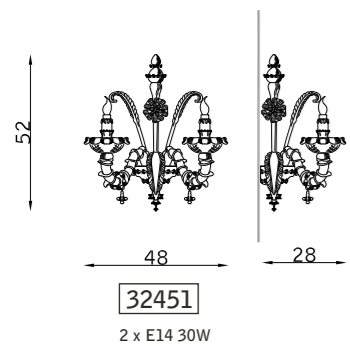

## DOGE

Lampadario veneziano in vetro soffiato con lavorazione Cà Rezzonico disponibile nei colori vetro trasparente + argento TR +AR, vetro trasparente + oro TR + OR, vetro fumé + oro FM + OR, vetro ametista + argento AT + AR, con meccaniche in metallo cromato oppure dorato in funzione della decorazione dei vetri.

*Venetian chandelier in blown glass with Cà Rezzonico processing available in transparent glass + silver TR +AR, transparent glass + gold TR + OR, smoked glass + gold FM + OR, amethyst glass + silver AT + AR, with chromed or gold-plated metal mechanics depending on the decoration of the glass.*





IMPERATRICE

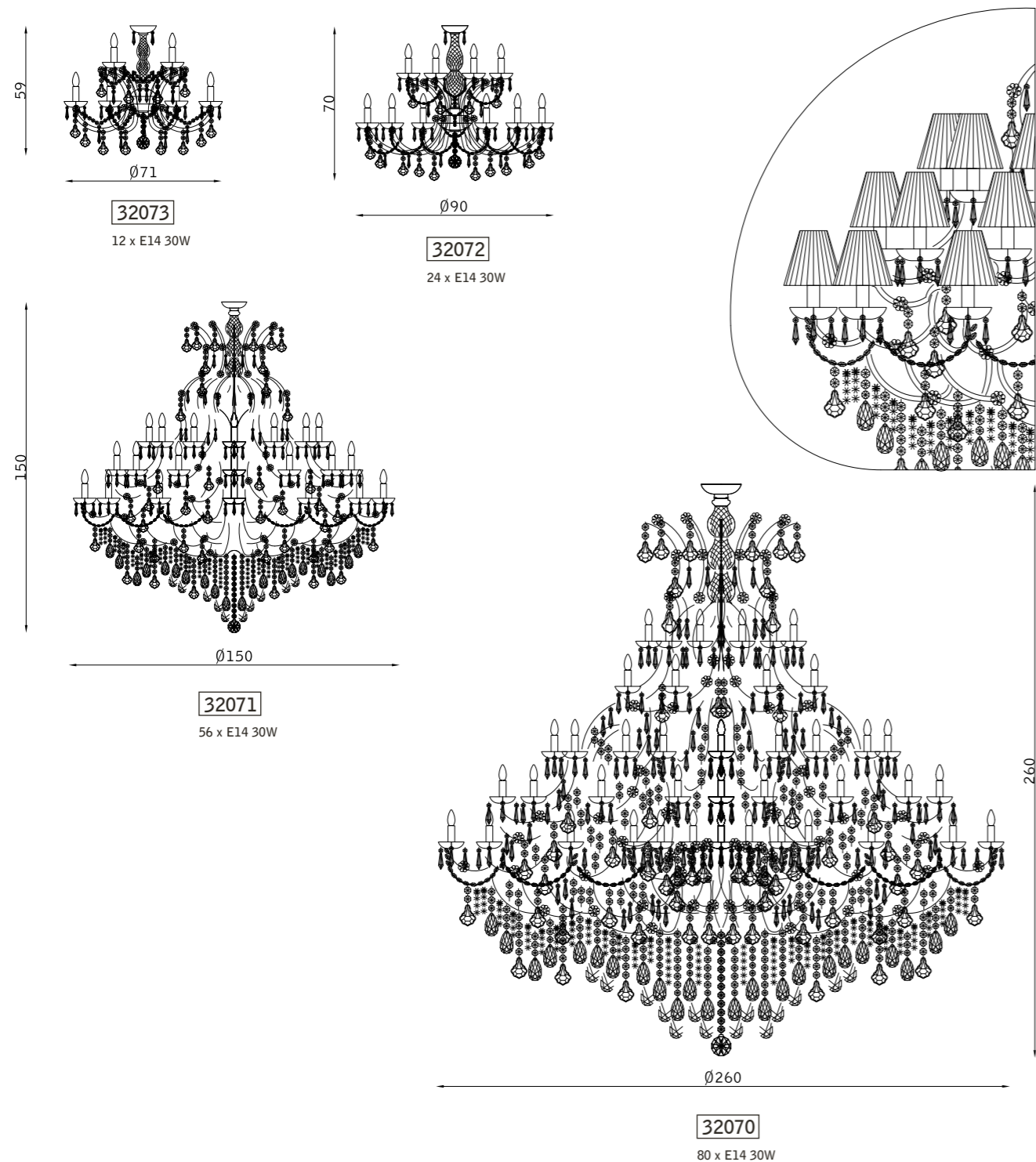

## IMPERATRICE

Lampadario in stile "Maria Teresa" con parti in cromo (102), faccette in vetro trasparente TR sui bracci e pendagliera in cristallo al piombo CR. Optional paralumi fasciati bianco lana (036).

"Maria Teresa" chandelier with chrome parts (102), TR transparent glass facets on the arms and CR lead crystal pendants. Optional lampshades in wool-white (036).

PARETE WALL

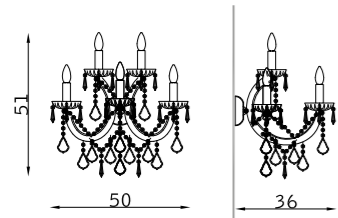

32074

5 x E14 30W

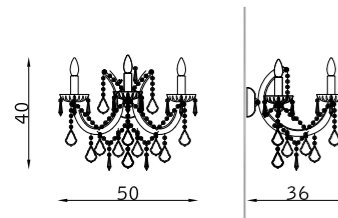

32075

3 x E14 30W

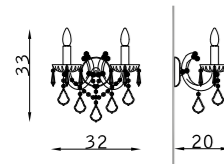

32076

2 x E14 30W

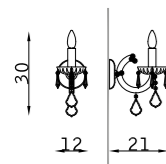

32077

1 x E14 30W



## IMPERATRICE

Lampadario in stile "Maria Teresa" con parti in cromo (102), faccette in vetro trasparente TR sui bracci e pendaglieria in cristallo al piombo CR. Optional paralumi fasciati bianco lana (036).

*"Maria Teresa" chandelier with chrome parts (102), TR transparent glass facets on the arms and CR lead crystal pendants. Optional lampshades in wool-white (036).*



FIORE

PARETE WALL

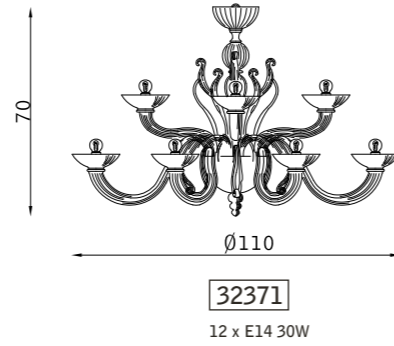
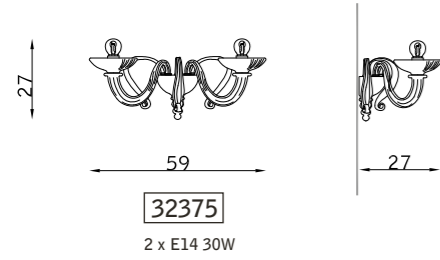

SOSPENSIONE PENDANT

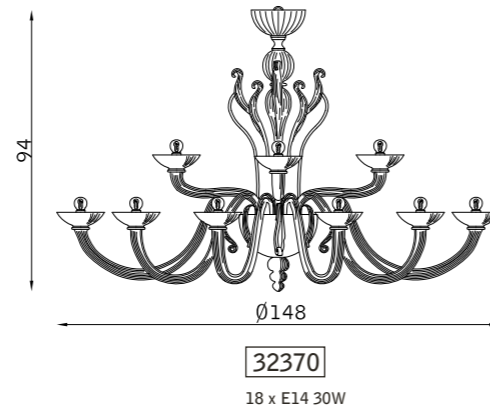
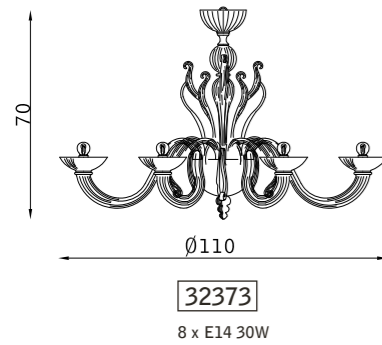
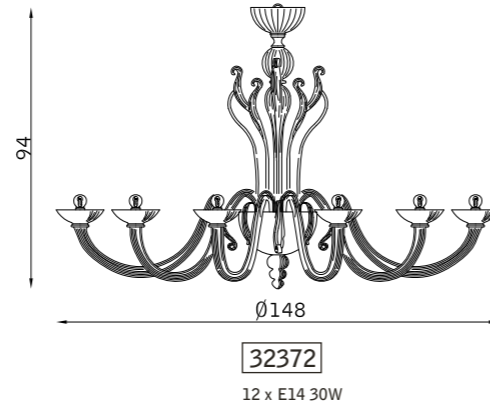
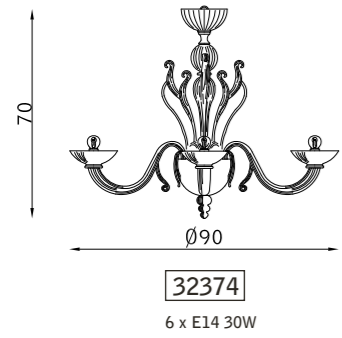

## FIORE

Lampadario veneziano in vetro soffiato disponibile nei colori vetro fumé VFM, blu VBL, bianco latte VBC, oppure in altri colori a scelta.

Venetian lamp in blown glass available in smoked glass VFM, blue VBL, milk white VBC, or in other colours of your choice.





SOFFIO



PARETE WALL

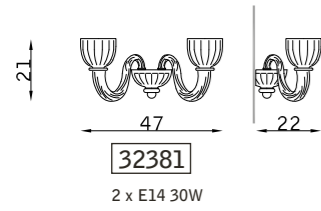

SOSPENSIONE PENDANT

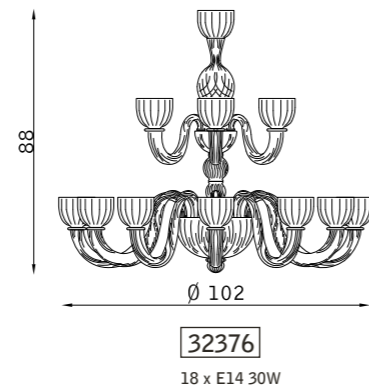
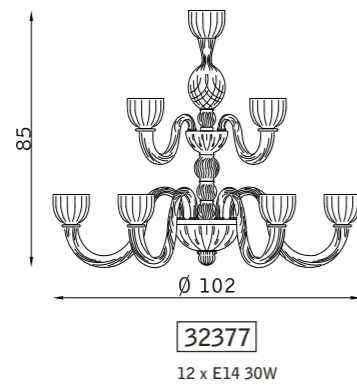
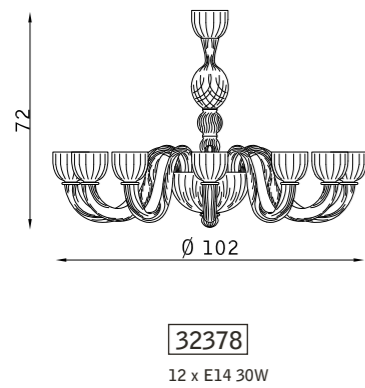
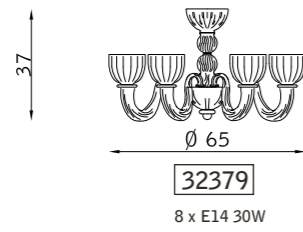
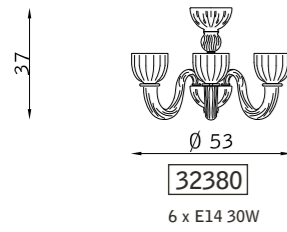

## SOFFIO

Lampadario veneziano in vetro soffiato disponibile nelle finiture cromo (102) + vetro fumé FM, cromo (102) + vetro trasparente TR, oro (145) + vetro avorio latte AL, oro (145) + vetro ambra AM, oppure in altri colori a scelta.

*Venetian blown glass chandelier available in chrome (102) + smoked glass FM, chrome (102) + transparent glass TR, gold (145) + milk ivory glass AL, gold (145) + amber glass AM, or in other colours of your choice.*



VIOLANTE

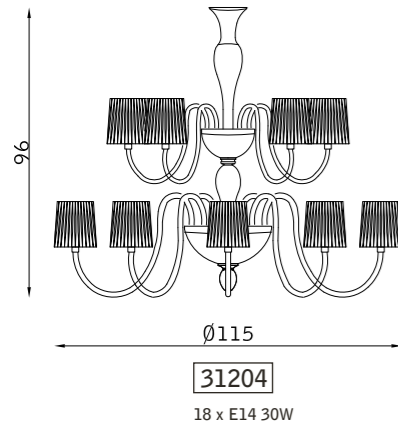
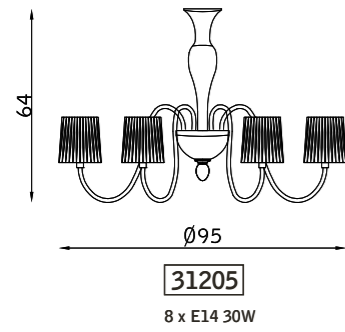

## VIOLANTE

Lampadario veneziano disponibile nelle finiture cromo (102) + vetro fumé FM con paralume plissé bianco (090), cromo (102) + vetro trasparente TR con paralume plissé marrone (095), oro (145) + vetro ambra AM con paralume plissé avorio (099), oro (145) + vetro ametista AT con paralume plissé avorio (099), oppure in altri colori a scelta.

*Venetian chandelier available in chrome (102) + smoked glass FM with white pleated lampshade (090), chrome (102) + transparent glass TR with brown pleated lampshade (095), gold (145) + amber glass AM with ivory pleated lampshade (099), gold (145) + amethyst glass AT with ivory pleated lampshade (099) or in other colors of your choice.*



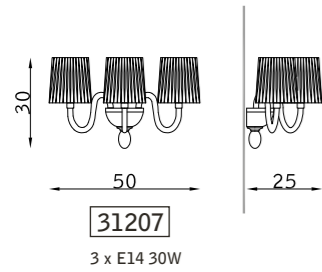
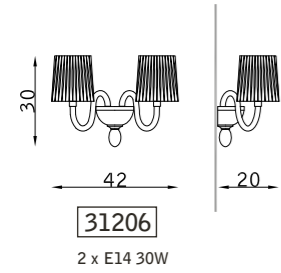

## VIOLANTE

Lampadario veneziano disponibile nelle finiture cromo (102) + vetro fumé FM con paralume bianco (090), cromo (102) + vetro trasparente TR con paralume marrone (095), oro (145) + vetro ambra AM con paralume avorio (099), oro (145) + vetro ametista AT con paralume avorio (099), oppure in altri colori a scelta.

*Venetian chandelier available in chrome (102) + smoked glass FM with white lampshade (090), chrome (102) + transparent glass TR with brown lampshade (095), gold (145) + amber glass AM with ivory lampshade (099), gold (145) + amethyst glass AT with ivory lampshade (099) or in other colors of your choice.*





SPRING

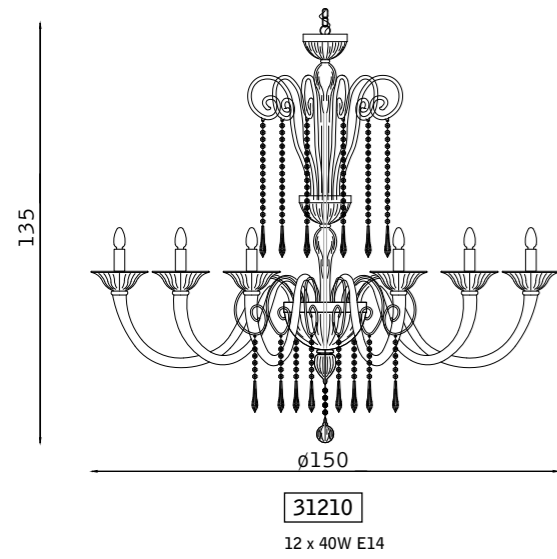

## SPRING

Lampadario veneziano in vetro soffiato con pendenti in cristallo al piombo disponibile nei colori vetro trasparente VTR, verde VVR, nero VNE, oppure in altri colori a scelta.

*Venetian lamp in blown glass with lead crystal drops and beads available in transparent glass VTR, green VVR, black VNE, or in other colours of your choice.*



CLASSICA

SOSPENSIONE PENDANT

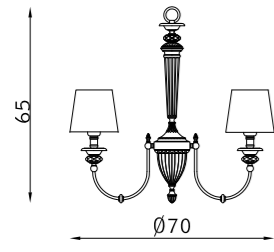

10362/S5

5 x E27 30W

PARETE WALL

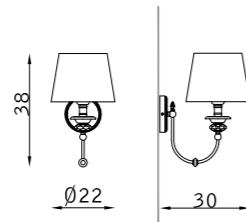

10364

1 x E27 30W

COMODINO BEDSIDE

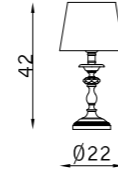

10366

1 x E27 30W

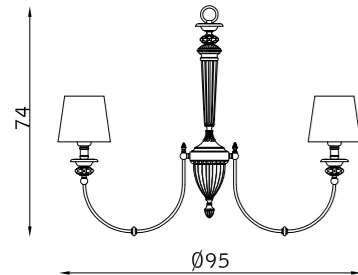

10363/S8

8 x E27 30W

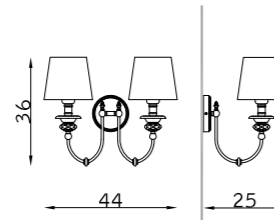

10365

2 x E27 30W

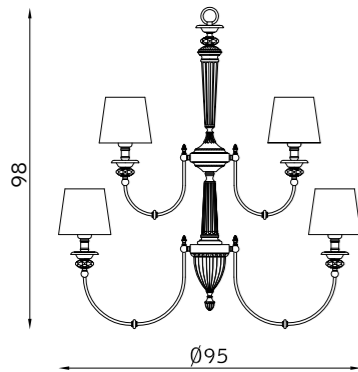

10363/S8+4

12 x E27 30W

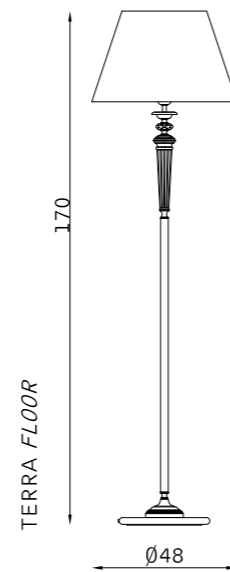

TERRA FLOOR

10367

1 x E27 77W

## CLASSICA

Lampada in ottone con finitura in ottone satinato (120), particolari in ottone lucido (106), elementi in cristallo al piombo CR e paralumi plissé avorio (083).

Brass lamp with satin finish brass (120), polished brass detailing (106), lead crystal and ivory pleated lampshades (083).







VOLA



## VOLA

Lampada in ottone disponibile nelle finiture nichel satinato (101) con particolari nichel lucido (103) oppure in cromo nero (104) con particolari nichel lucido (103), con cristalli al piombo e paralume plissé bianco (003), o in altri colori a scelta.

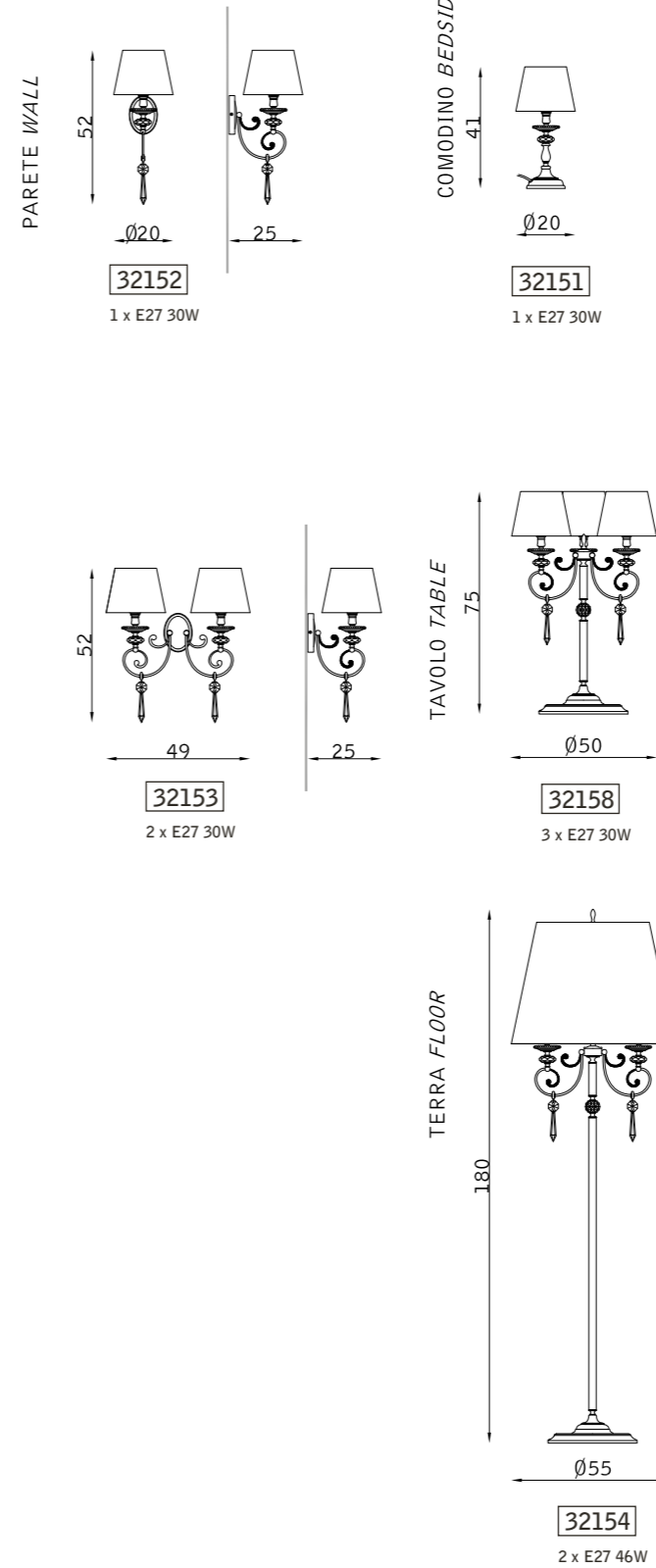
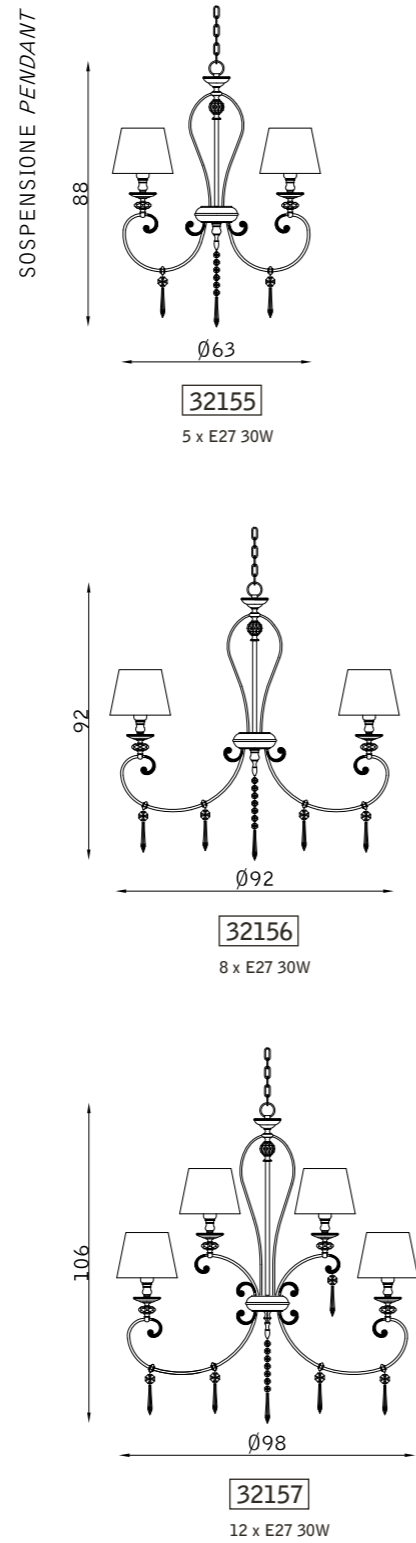

## VOLA

Brass lamp available in satin nichel (101) finish with polished nichel (103) details or black chromed (104) finish with polished nichel (103) details, with lead crystal and pleated lampshade available in white (003), or in other colors of your choice.





PARETE WALL

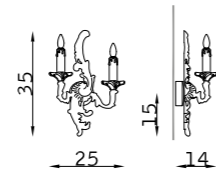

32136

2 x E14 30W

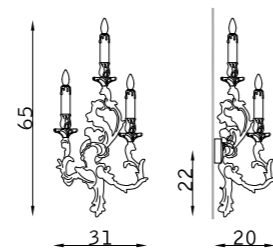

32137

3 x E14 30W

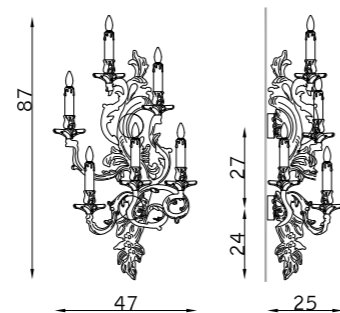

32138

6 x E14 30W



## SETTECENTO

Lampada in fusione artistica toscana in lega di ottone con finitura oro 24Kr antichizzato (133).

Brass lamp in Tuscan artistic fusion in brass alloy with antique gold 24 Kr finish (133).

# SETTECENTO

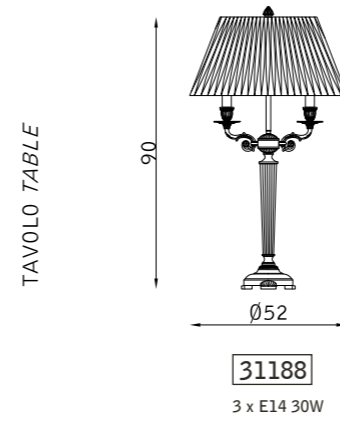
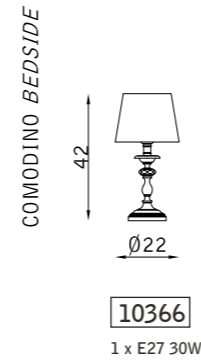
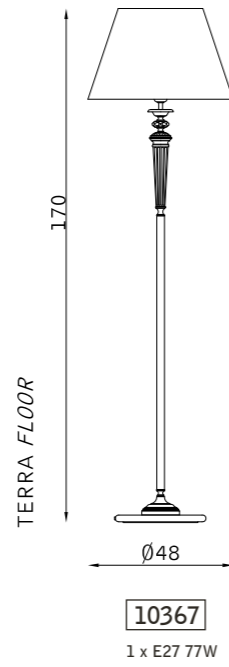

## CLASSICA

Lampada in ottone con finitura in ottone satinato (120), particolari in ottone lucido (106), elementi in cristallo al piombo CR e paralume plissé avorio (083).

Brass lamp with satin finish brass (120), polished brass detailing (106), lead crystal and ivory pleated lampshade (083).

## SOLITARIA

Lampada in ottone con finitura oro zecchino 24 KT (105) e paralume plissé avorio (088).

Brass lamp with a 24 KT gold (105) finish and pleated ivory lampshade (088).

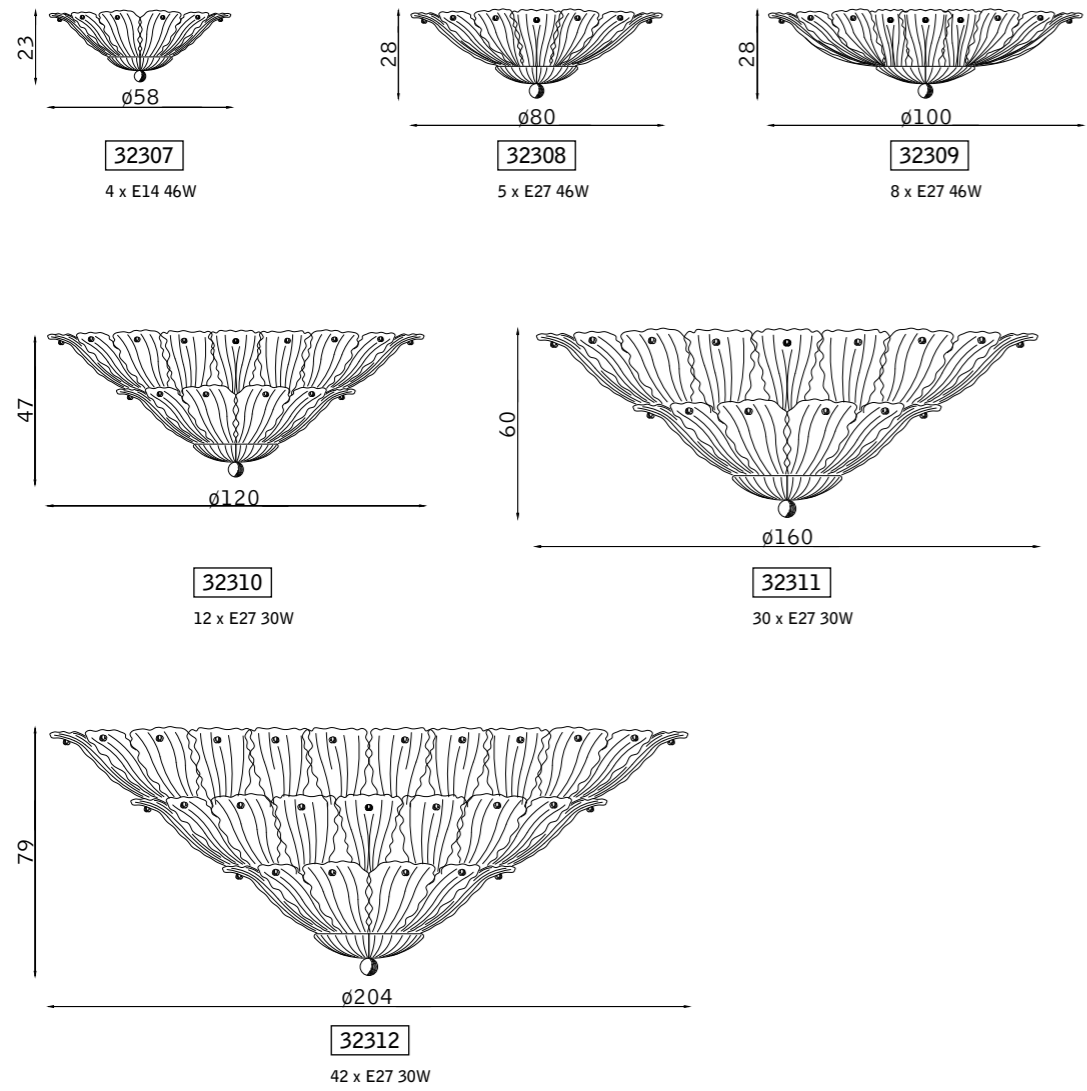

## SBOCCIA

Lampada in vetro piastra disponibile nella finitura oro (145) + vetro graniglia trasparente GTR oppure nella finitura oro (145) con vetro graniglia ambra GAM.

Plate glass lamp available in gold finish (145) + transparent grit glass GTR or in gold finish (145) with amber grit glass GAM.

# SBOCCIA

PARETE WALL

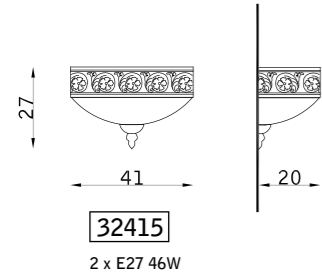

PLAFONIERA CEILING

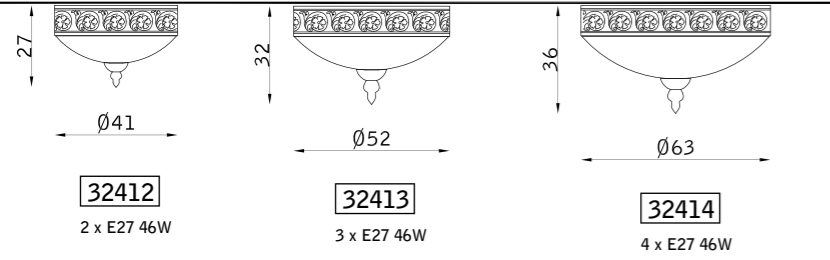

## BAROCCA

Lampada disponibile nelle finiture bronzo scuro (127) + vetro avorio satinato AS, cromo (102) + vetro bianco satinato BS e bianco (190) + vetro bianco satinato BS.

Lamp available in dark bronze finishes (127) + satin ivory glass AS, chrome (102) + satin white glass BS and white (190) + satin white glass BS.

# BAROCCA

PARETE WALL

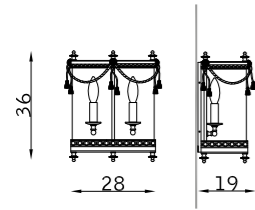

31123  
2 x E14 30W

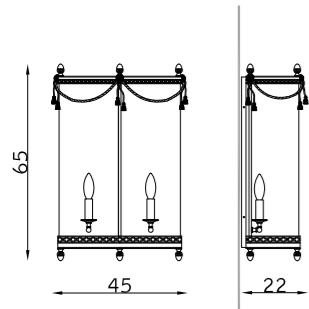

31124  
2 x E14 30W

SOSPENSIONE PENDANT

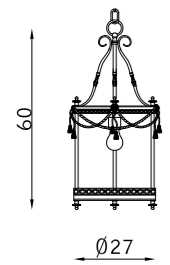

31122  
1 x E27 46W

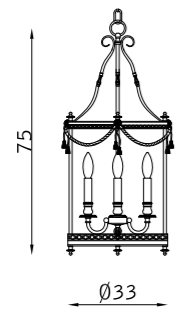

31121  
3 x E14 30W

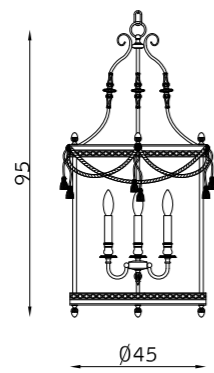

31120  
3 x E14 30W

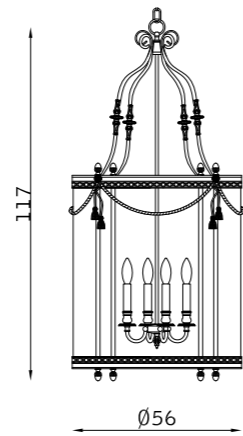

31119  
4 x E14 30W

## LANTERNA

Lampada in ottone con fascia traforata e dettagli in fusione di ottone disponibile nella finitura oro francese (111) con vetro curvo trasparente TR, oppure in altri colori a scelta.

*Brass lamp with perforated band and details in cast brass available in french gold (111) finish with curved transparent glass TR, or in other colours of your choice.*



# LANTERNA

SOSPENSIONE PENDANT

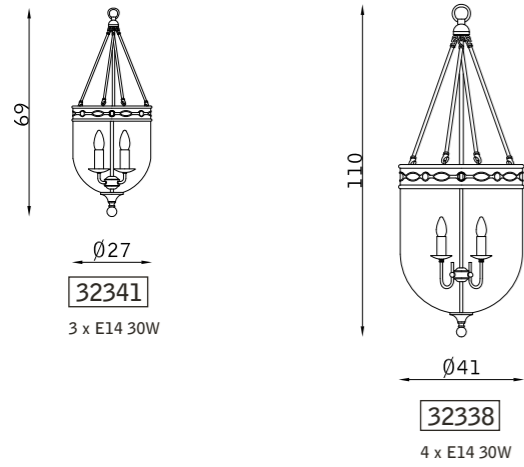

PLAFONIERA CEILING

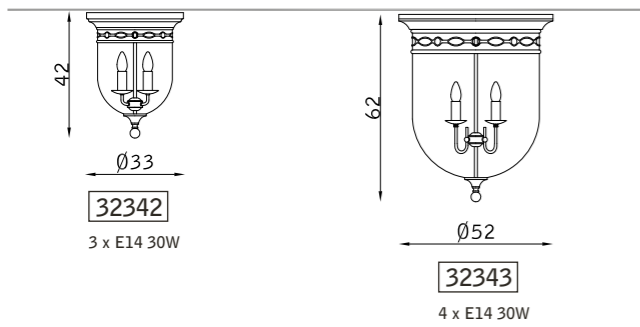

PARETE WALL

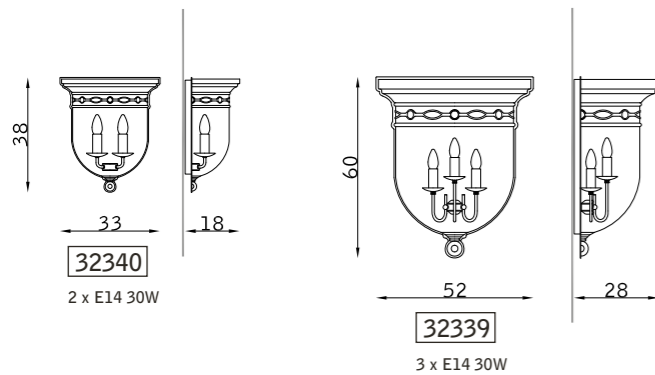

## MARE

Lampada in metallo disponibile nelle finiture cromo (102), oppure nero opaco (191), oppure in altri colori a scelta con vetro trasparente TR.

*Metal amp available in chrome (102), or matt black (191), or in other finish of your choiche with transparent glass TR.*



# MARE





STELLATA

PLAFONIERA CEILING

BASE TONDA CIRCULAR BASE

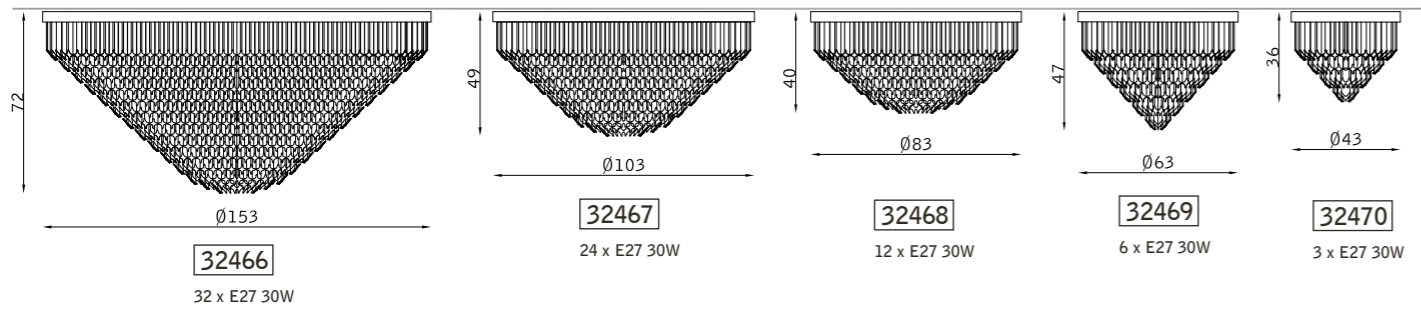

PLAFONIERA CEILING

BASE OVALE OVAL BASE

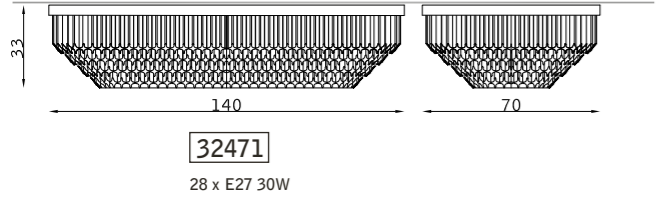

BASE QUADRATA SQUARE BASE

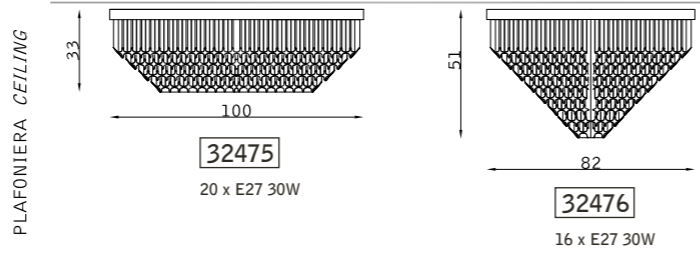

PLAFONIERA CEILING

BASE RETTANGOLARE RECTANGULAR BASE

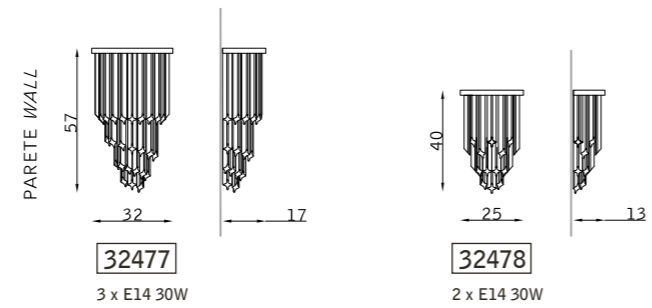
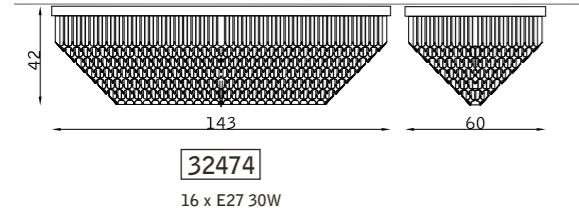
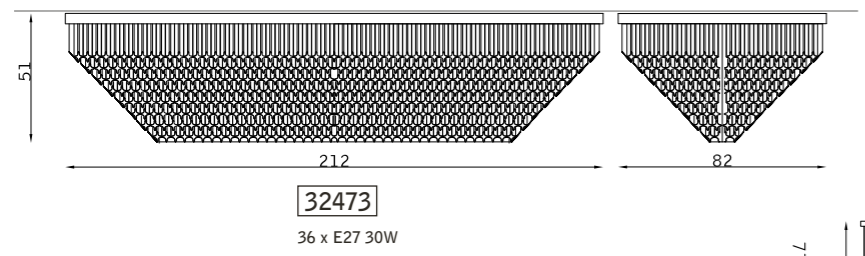
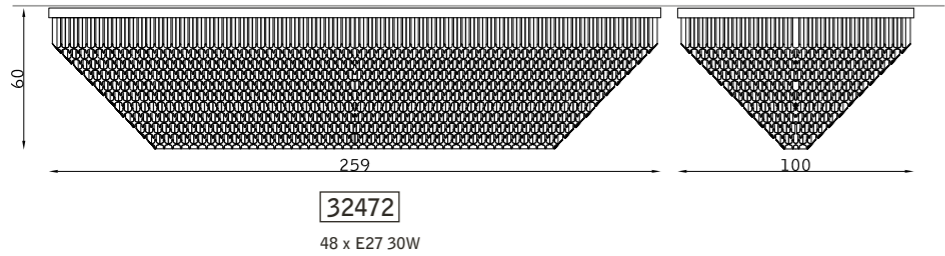

**STELLATA**

Lampade componibili con quadriedri disponibili nelle combinazioni cromo (102) + vetro trasparente TR, dorato (145) + vetro trasparente TR, bronzo scuro (127) + vetro trasparente TR, oppure in altri colori a scelta.

Modular lamps with quadrihedra available in combinations chrome (102) + transparent glass TR, gilded (145) + transparent glass TR, dark bronze (127) + transparent glass TR, or in other colours of your choice.





ICONA

SOSPENSIONE PENDANT

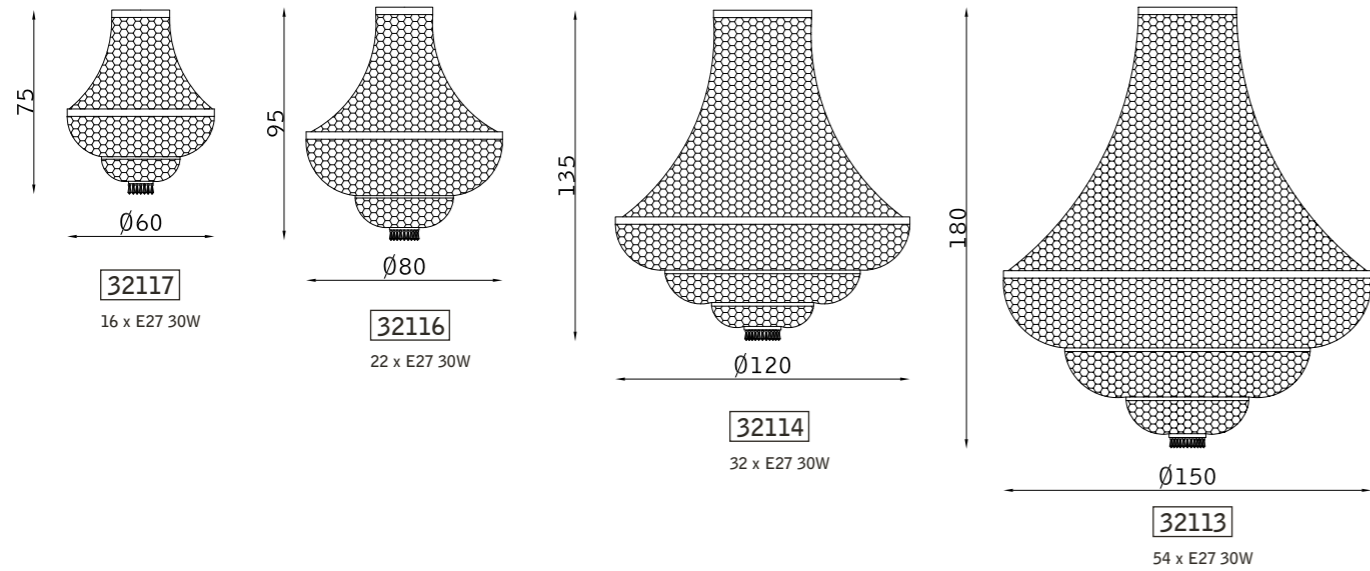

PLAFONIERA CEILING

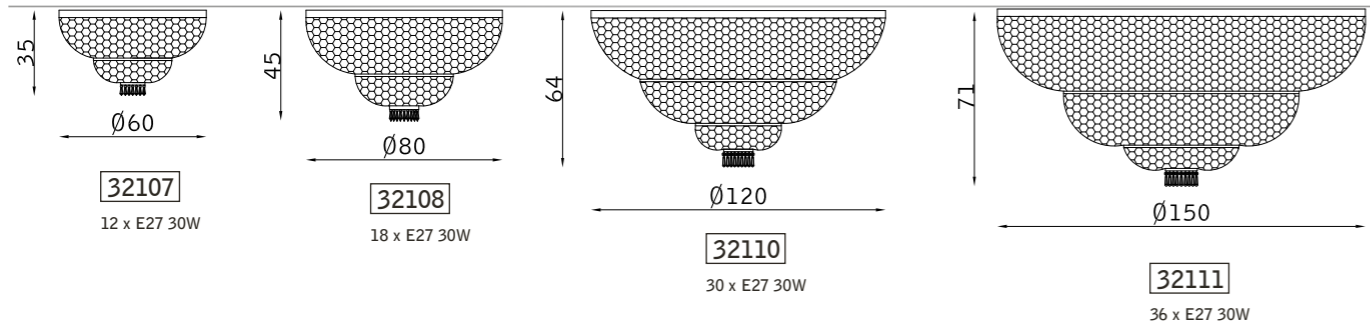

PARETE WALL

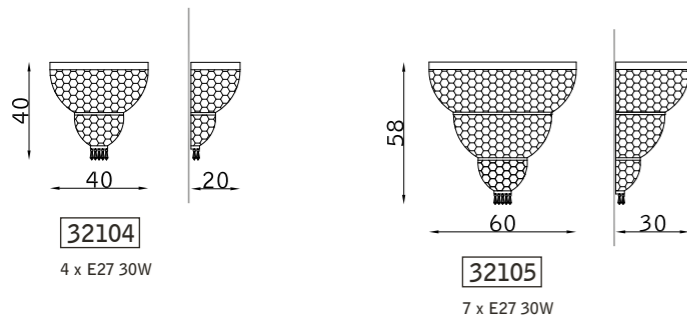

## ICONA

Lampade sospese o plafoniere con catene di ottagoni in cristallo disponibili nelle combinazioni cromo (102) + cristalli al piombo CR, oro zecchino (105) + cristalli al piombo CR, bronzo scuro (127) + cristalli al piombo CR.

*Hanging or ceiling lamps with crystal octagon chains available in combinations chrome (102) + lead crystal CR, pure gold (105) + lead crystal CR, dark bronze (127) + lead crystal CR.*



PARETE WALL

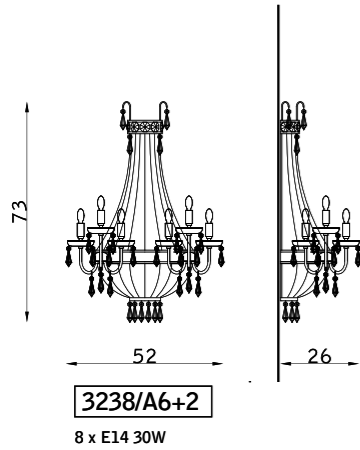

SOSPENSIONE PENDANT

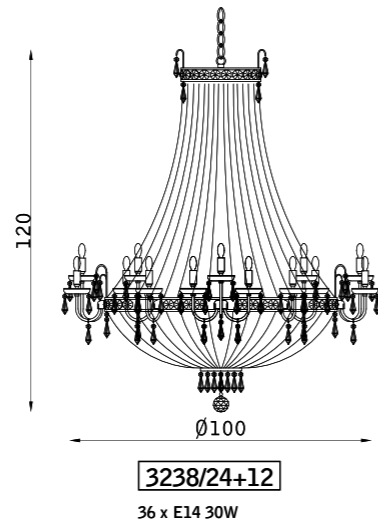
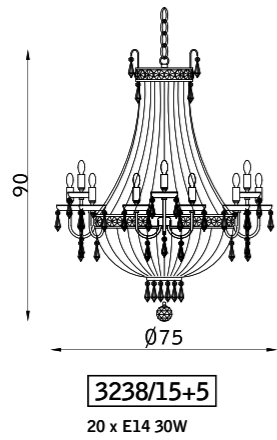
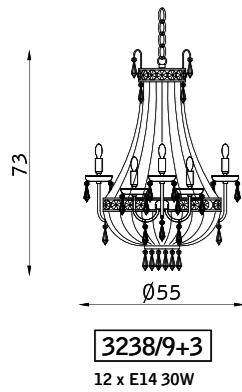

## CHANDELIER

Lampada in stile classico con bracci e cestelli composti da catene di ottagoni in cristallo disponibile nelle finiture oro zecchino (105) + cristalli al piombo CR oppure bronzo scuro (127) + cristalli al piombo CR.

*Brass lamp classic style with arms and baskets made up of crystal octagon chains available in pure gold (105) + lead crystals CR or dark bronze (127) + lead crystals CR.*



# CHANDELIER



AMANTIDE

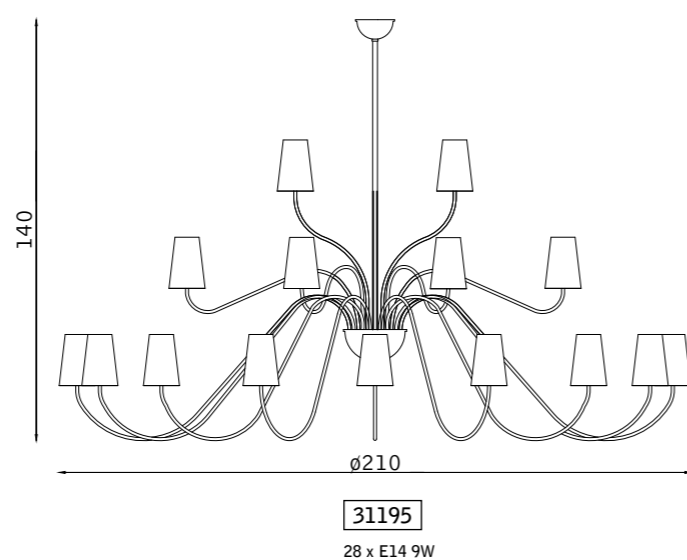
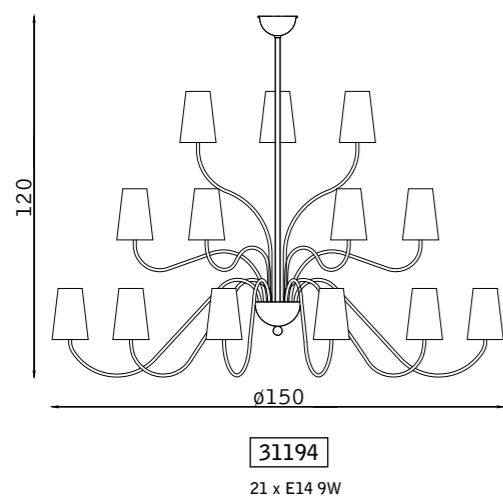
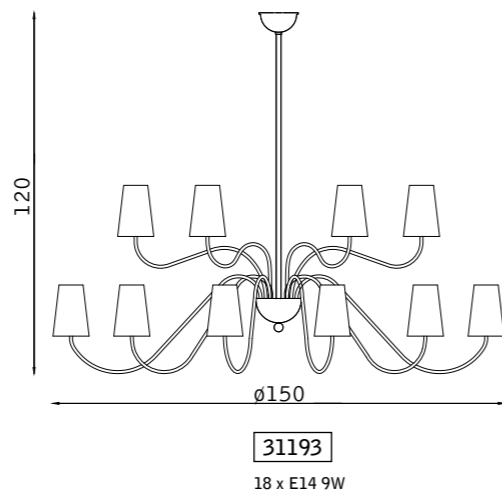
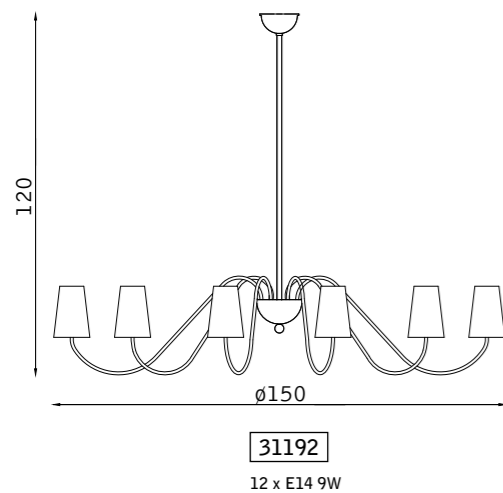

## AMANTIDE

Lampada in metallo disponibile nei colori avorio opaco (187) con paralume liscio avorio (803), marrone opaco (188) con paralume liscio pesca (826), oppure nelle finiture ottone satinato (120) con paralume liscio nero interno oro (00010), nichel satinato (101) con paralume liscio bianco (800), oppure in altre combinazioni di colori a scelta.

*Metal lamp available in matt ivory (187) with smooth ivory lampshade (803), matt brown (188) with smooth peach rose lampshade (826), or in satin brass (120) finishes with smooth black inside gold lampshade (00010), satin nickel (101) with smooth white lampshade (800), or in other colour combinations of your choice.*

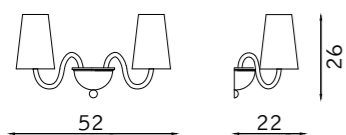
**31189**

2 x E14 9W

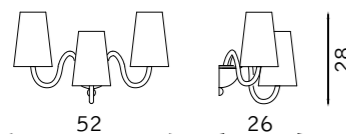
**31190**

3 x E14 9W

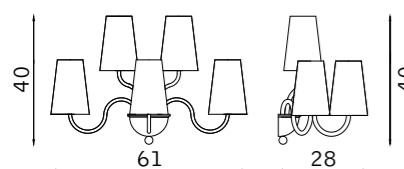
**31191**

5 x E14 9W

## AMANTIDE

Lampada in metallo disponibile nei colori avorio opaco (187) con paralume liscio avorio (803), marrone opaco (188) con paralume liscio pesca (826), oppure nelle finiture ottone satinato (120) con paralume liscio nero interno oro (00010), nichel satinato (101) con paralume liscio bianco (800), oppure in altre combinazioni di colori a scelta.

*Metal lamp available in matt ivory (187) with smooth ivory lampshade (803), matt brown (188) with smooth peach rose lampshade (826), or in satin brass (120) finishes with smooth black inside gold lampshade (00010), satin nickel (101) with smooth white lampshade (800), or in other colour combinations of your choice.*





PARETE WALL

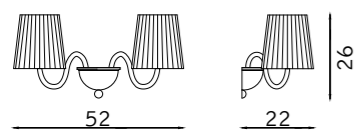

**31189**  
2 x E14 9W

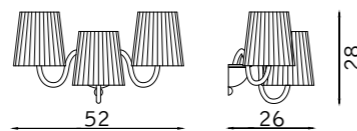

**31190**  
3 x E14 9W

SOSPENSIONE PENDANT

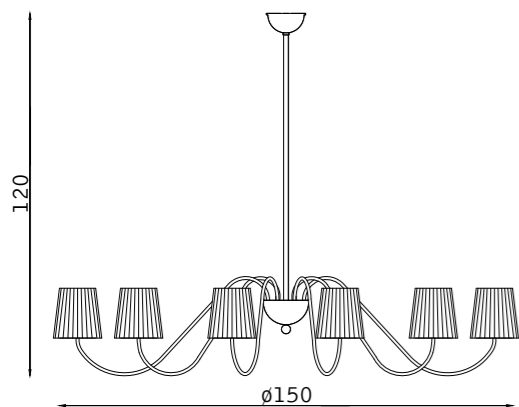

**31192**  
12 x E14 9W

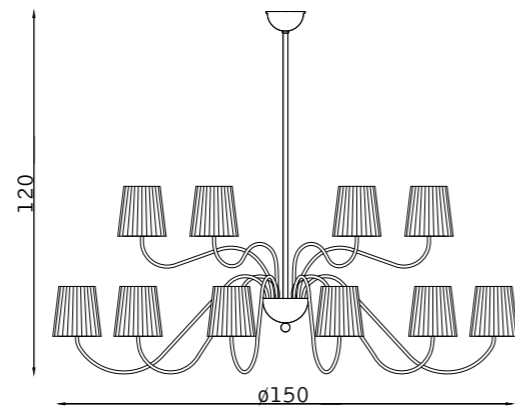

**31193**  
18 x E14 9W

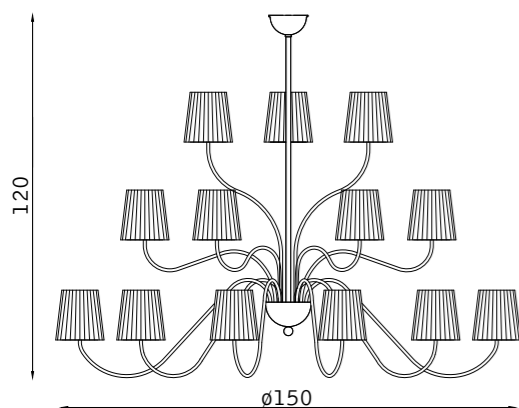

**31194**  
21 x E14 9W

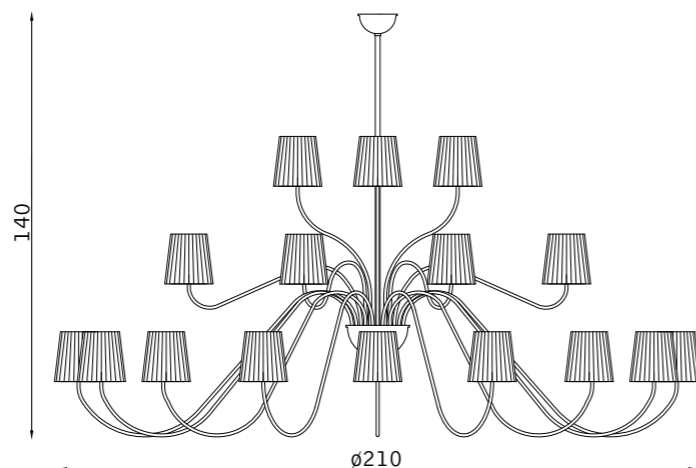

**31195**  
28 x E14 9W

## AMANTIDE

Lampada in metallo disponibile nei colori avorio opaco (187) con paralume plissé fasciato beige (099), marrone opaco (188) con paralume plissé fasciato beige (099), oppure nelle finiture ottone satinato (120) con paralume plissé fasciato nero (094), nichel satinato (101) con paralume plissé fasciato bianco (090), oppure in altre combinazioni di colori a scelta.

*Metal lamp available in matt ivory (187) with pleated lampshade in beige (099), matt brown (188) with pleated lampshade in beige (099), or in satin brass (120) with pleated lampshade in black (094), satin nickel (101) with white-wrapped pleated lampshade (090), or in other colour combinations of your choice.*





TAVOLO TABLE

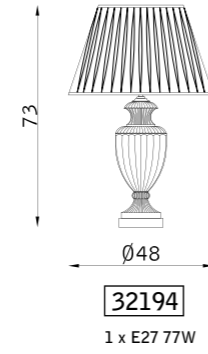

COMODINO BEDSIDE

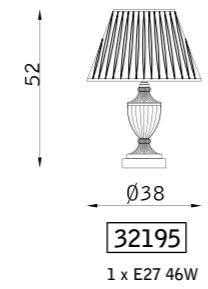

## ATMOSFERA

Lampada in cristallo al piombo disponibile nelle finiture ottone lucido (106) + cristallo trasparente CR oppure ottone lucido (106) + cristallo decorato ambra CRA con paralumi plissé nei colori bordeaux (023) oppure avorio (024).

*Lead crystal lamp available in polished brass finishes (106) + transparent CR crystal or polished brass (106) + amber decorated CRA crystal, with pleated lampshades in bordeaux (023) or ivory (024).*





SOSPENSIONE PENDANT

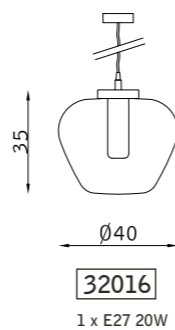

TAVOLO TABLE

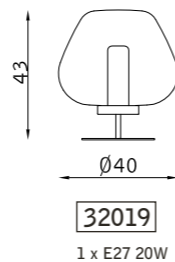

TAVOLO TABLE

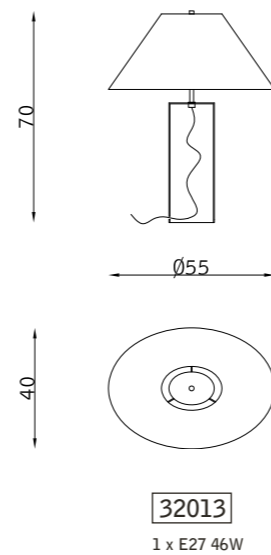

## FLUIDI

Lampada con vetro soffiato e dettagli in metallo disponibile nelle combinazioni bronzo scuro (127) + vetro fumé FM oppure bronzo scuro (127) + vetro tabacco TB.

Lamp with blown glass and metal details available in dark bronze combinations (127) + smoked glass FM or dark bronze (127) + tobacco glass TB.

## SHOCK

Lampada in borosilicato con parti in metallo disponibile nelle finiture ottone lucido (106) + vetro trasparente TR con paralumi lisci verde acido (233) oppure fucsia (349) e cromo (102) + vetro trasparente TR con paralume liscio turchese (489)

Borosilicate lamp with metal parts available in polished brass finishes (106) + transparent glass TR with smooth acid green (233) or fuchsia (349) lampshades and chrome (102) + transparent glass TR with smooth turquoise (489) lampshade.

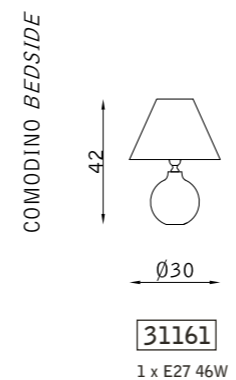
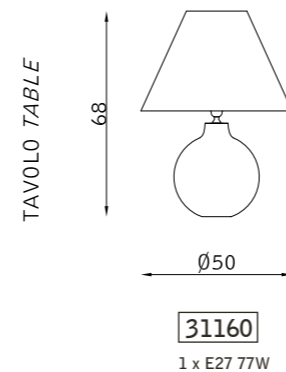
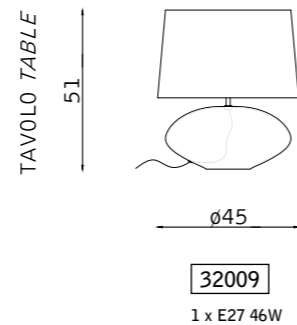
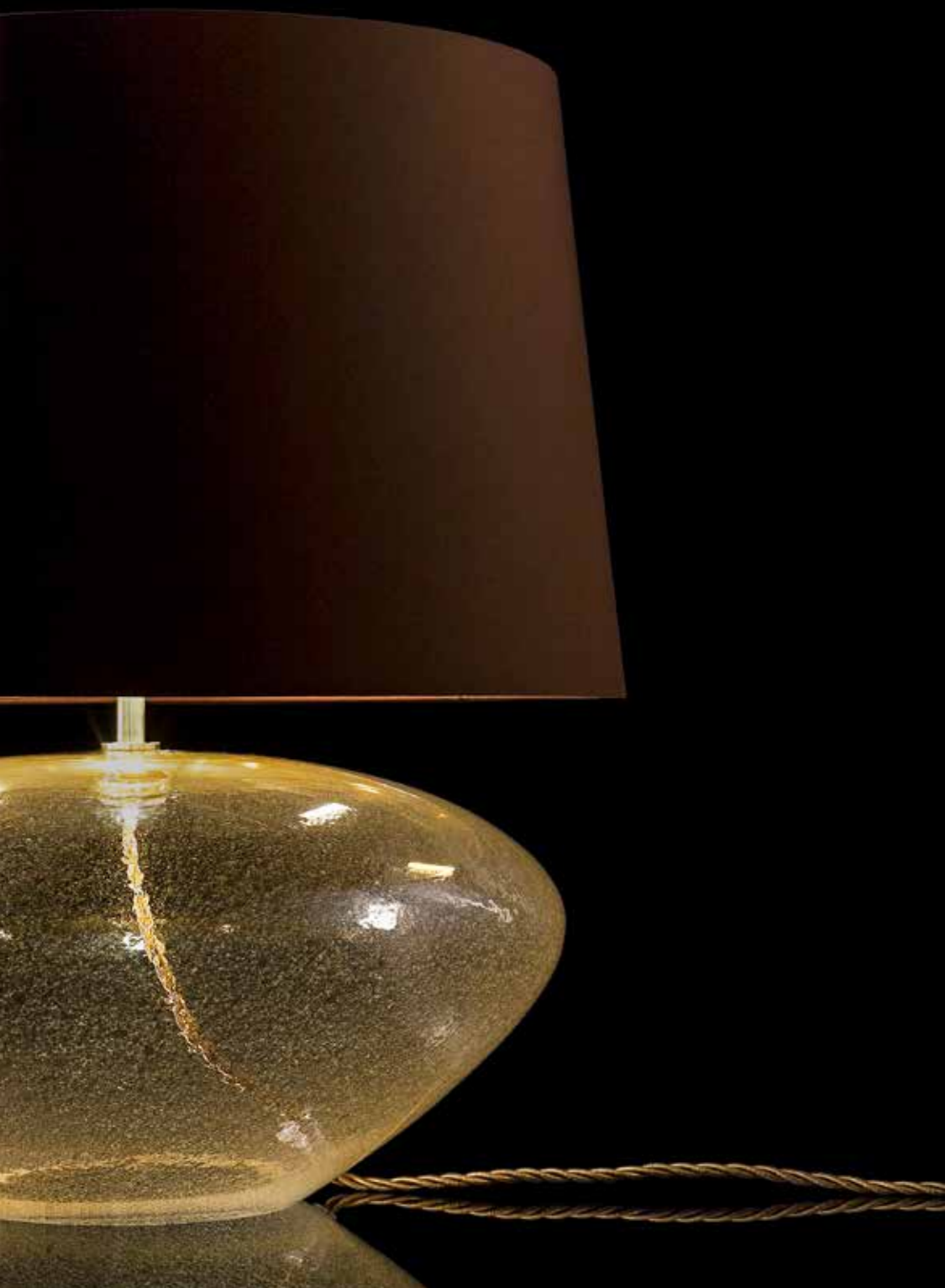

## FLUTTUANTE

Lampada in vetro veneziano soffiato disponibile nelle combinazioni cromo (102) + vetro trasparente antico TRA con paralume liscio salvia scuro (545) oppure ottone lucido (106) + vetro ambra antico AMA con paralume liscio caramello (551).

*Blown venetian glass lamp available in chrome (102) + antique transparent glass TRA with dark sage smooth lampshade (545) or polished brass (106) + antique amber glass AMA with caramel smooth lampshade (551).*

## SVEVA

Lampada in ceramica disponibile nei colori platino PL con paralume liscio bianco (800), oppure bianco lucido con paralume liscio nero (000), oppure in altri colori a scelta.

*Ceramic lamp available in platinum PL with white (800) smooth lampshade, or glossy white with black (000) smooth lampshade, or in other colours of your choice.*

PARETE WALL

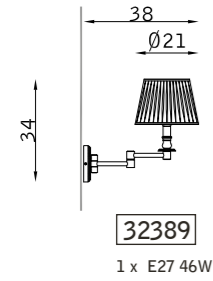

TAVOLO TABLE

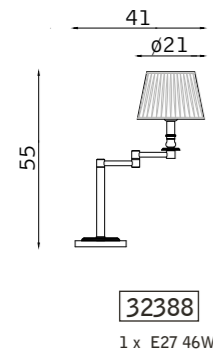

TERRA FLOOR

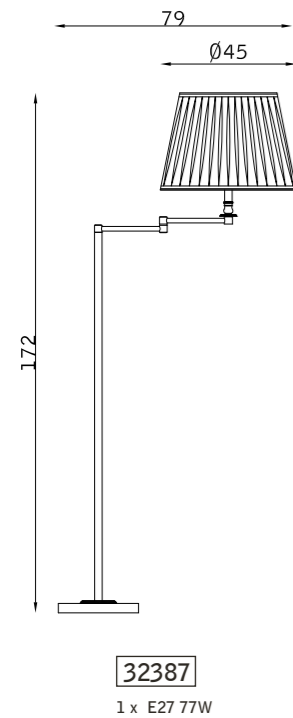

## SEMPRE

Lampada con braccio snodato, struttura in fusione di ottone e finitura in satinato (120) con paralume plissé avorio (503), oppure in altre finiture e colori a scelta.

Lamp with articulated arm, cast brass structure and satin brass finish (120) with pleated ivory (503) lampshade, or in other finishes and colours of your choice.



# SEMPRE



PARETE WALL

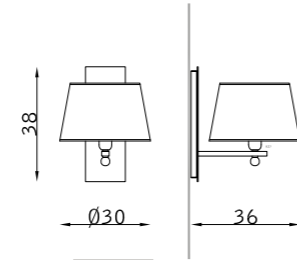

32249  
1 x E27 46W

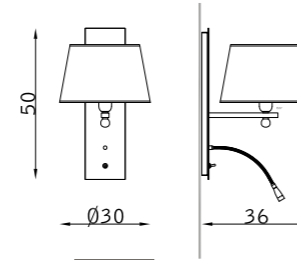

32250  
1 x E27 46W +  
LED 1 x 1,4W 3.000°K



**SOGNI** Design Pascal Desprez

Lampada da parete disponibile nelle finiture ottone lucido (106) con paralume liscio nero interno oro (00010), cromo (102) con paralume liscio bianco (424), bronzo scuro (127) con paralume liscio avorio (459).

Wall lamp available in polished brass finishes (106) with black gold inside (00010) smooth lampshade, chrome (102) with white (424) smooth lampshade, dark bronze (127) with ivory (459) smooth lampshade.

SOGNI

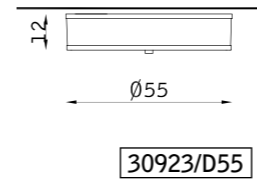
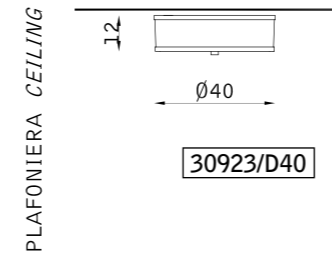
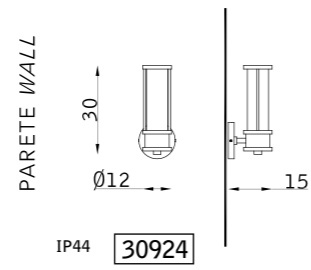

## ACQUA

Lampada in metallo disponibile nelle finiture cromo (102) con plexiglass bianco satinato PBS oppure in bronzo scuro (127) con plexiglass avorio satinato PAS.

## ACQUA

Metal lamp available in chrome finish (102) with satin white plexiglass PBS or dark bronze (127) with satin ivory plexiglass PAS.



PARETE WALL

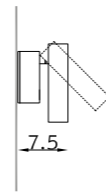
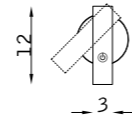

**32498**

1 LED 1,1W 350mA 3.200°K - 40°  
1 LED TOUCH

PARETE WALL

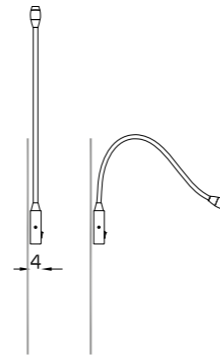
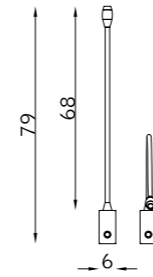

**32040**

LED 1 x 3,4W 2.900°K - 45°



## NIGHTBOOK Design Marco Piva

Lampada da lettura bordo letto con corpo in alluminio disponibile con finitura nichel satinato (101).

*Edge bed reading lamp with aluminum body available with satin nickel (101) finish.*

## DINAMICA Design Paul Connor

Lampada applique disponibile nelle combinazioni di colore cromo (102) + rivestimento in tessuto grigio TGR, bronzo scuro (127) + rivestimento in tessuto oro TOR, ottone lucido (106) + rivestimento in tessuto nero TNE, bronzo chiaro (126) + rivestimento in tessuto marrone TMA. Sorgente LED con lente concentrata per agevolare la luce lettura.

*Wall lamp available in chrome color combinations (102) + grey fabric cover TGR, dark bronze (127) + gold fabric cover TRO, polished brass (106) + black fabric cover TNE, light bronze (126) + brown fabric cover TMA. LED source with concentrated lens to facilitate reading light.*



TAVOLO TABLE

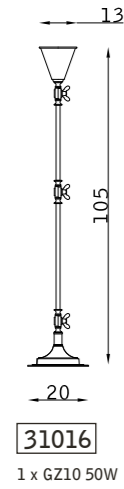

PLAFONIERA CEILING  
PARETE WALL

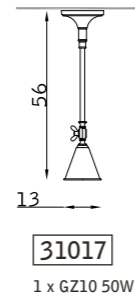

PLAFONIERA CEILING

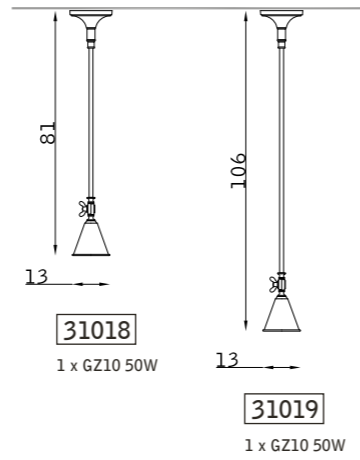

PLAFONIERA CEILING

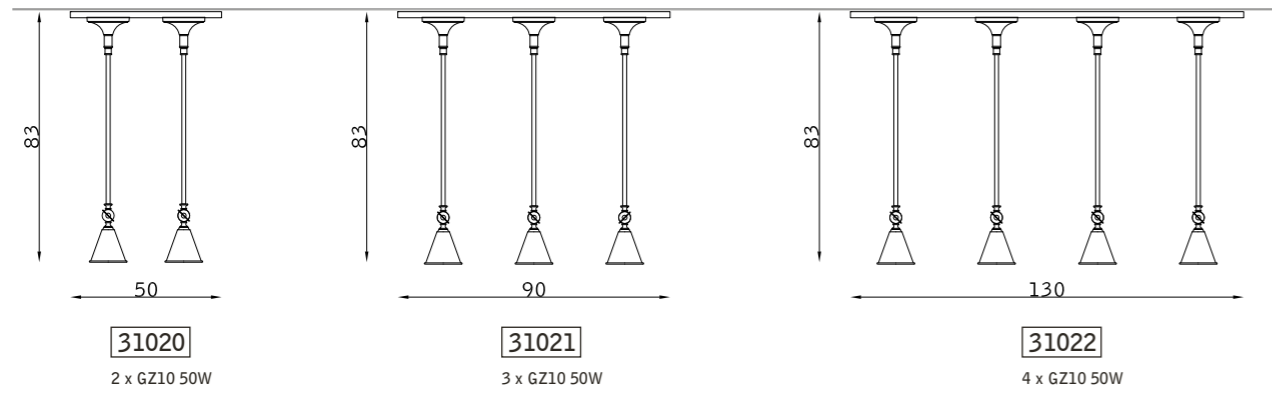

**BUGGLE** Design Celeste dell'Anna

Lampade orientabili e direzionabili a 360° in ottone con finitura nichel lucido (103).

360 ° directional adjustable lamps in brass with polished nickel finish (103).



PARETE WALL

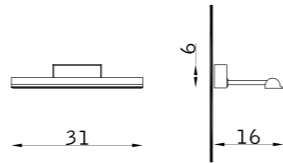

32260

LED 1 x 5W 2.700°K - 24V

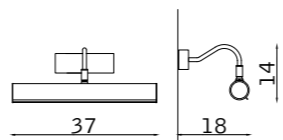

10577

2 x E14 30W

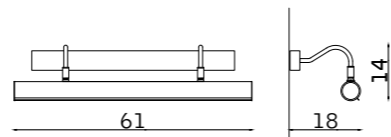

10185

2 x E14 30W



QUADRO

## QUADRO

Lampada in metallo disponibile nelle finiture nichel satinato (101) oppure bronzo scuro (127).

*Metal lamp available in satin nickel (101) or dark bronze (127) finish.*



MILANO

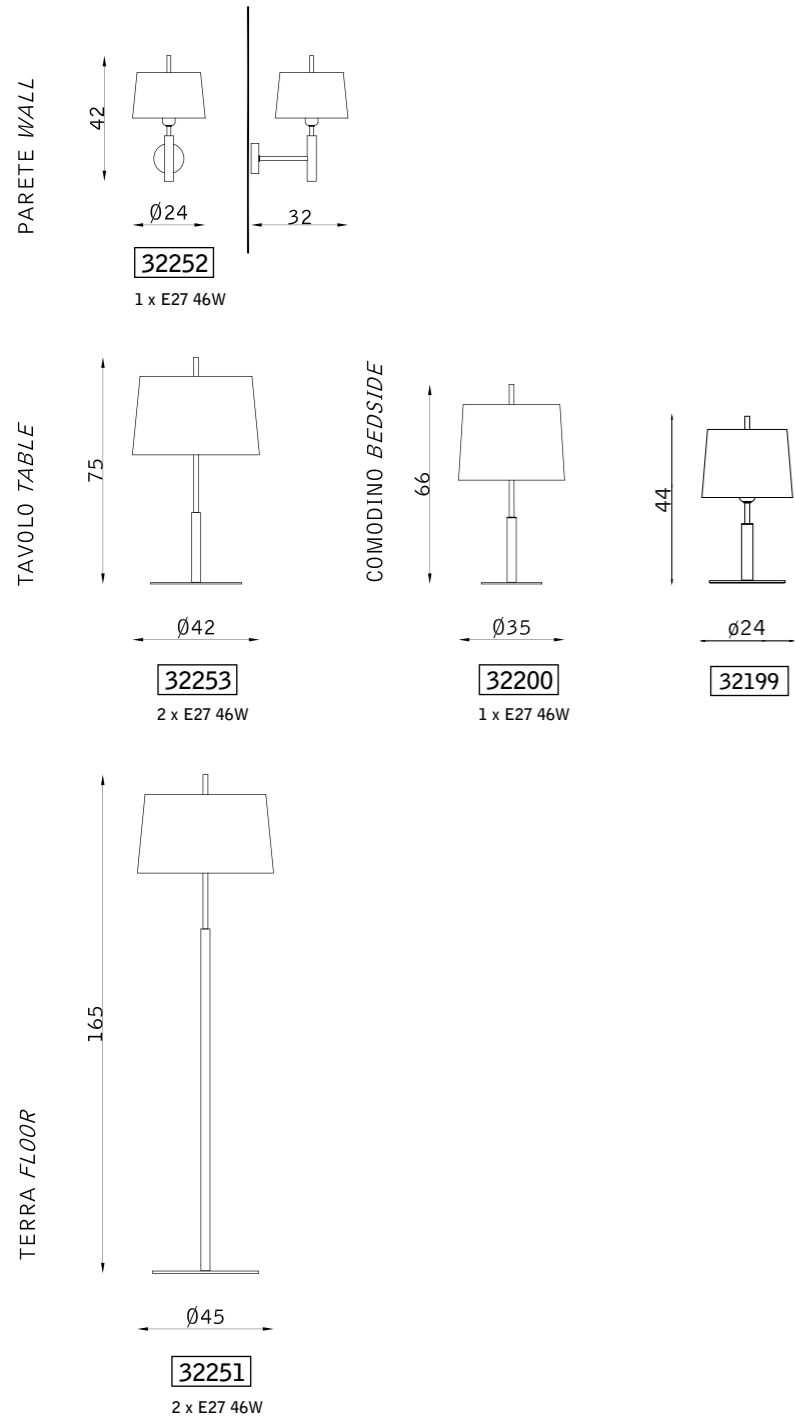

**MILANO** Design Paul Connor

Lampade in metallo disponibili nella finitura bronzo scuro (127) con paralume liscio beige (554), oppure in altre finiture e colori a scelta.

*Metal lamp available in dark bronze finish (127) with beige (554) smooth lampshade, or in other finishes and colours of your choice.*





GIOSTRA

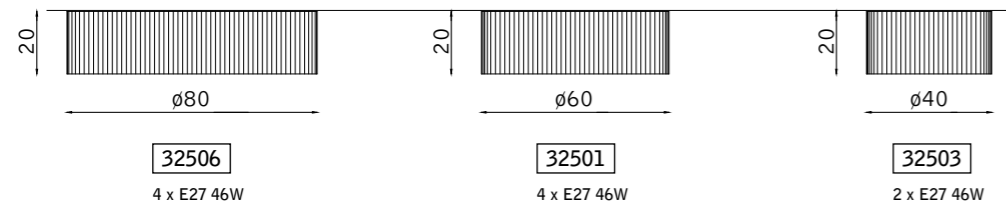
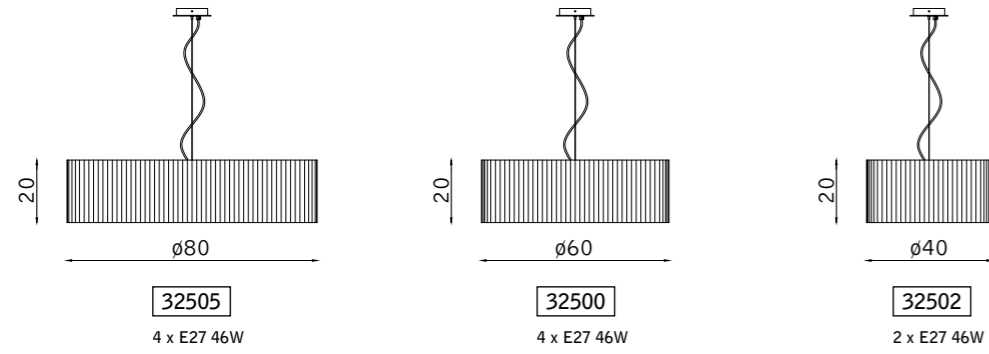

## GIOSTRA

Lampada con paralume plissé fasciato disponibile nei colori bianco (090) oppure grigio (063) abbinati alla finitura cromo (102), oppure in altri colori a scelta, e diffusore in plexiglass bianco opale.

*Lamp with pleated lampshade available in white (090) or gray (063) combined with chrome finish (102), or in other colors of your choice, and opal white plexiglass diffuser.*





BALLERINA

PARETE WALL

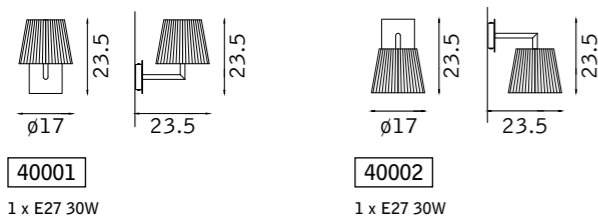

SOSPENSIONE PENDANT

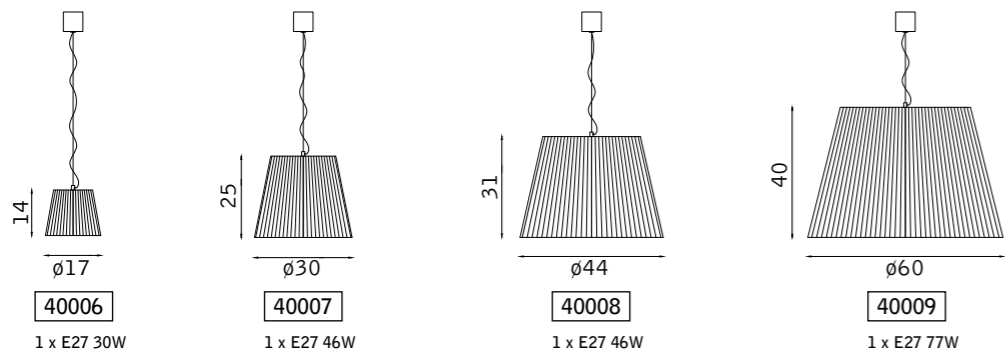

TAVOLO TABLE

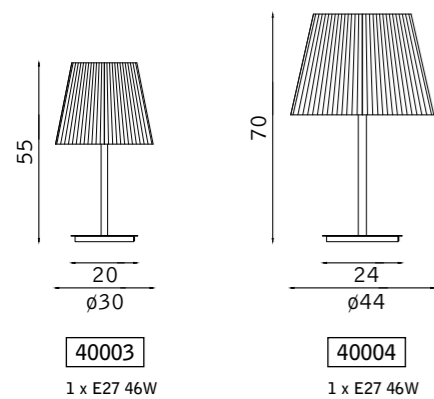

TERRA FLOOR

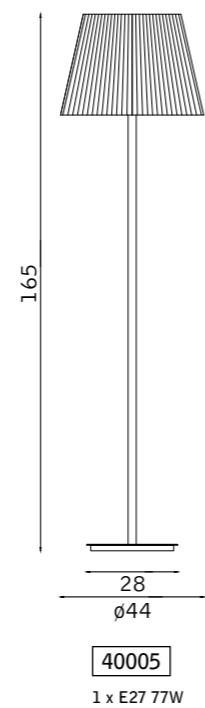

## BALLERINA

Lampada con paralume plissé fasciato disponibile nei colori bianco (090) oppure nero (094) abbinati alla finitura cromo (102), con paralume marrone (095) oppure avorio (099) abbinati alla finitura oro (145), oppure in altre combinazioni di colori a scelta e diffusore in plexiglass bianco opale. Le lampade da terra e da tavolo hanno base quadrata.

Lamp with plissé lampshade available in white (090) or black (094) combined with chrome finish (102) and with brown lampshade (095) or ivory (099) combined with gold finish (145), or in other colour combinations of your choice and opal white plexiglass diffuser. Floor lamp and table lamp have square base.





PARETE WALL

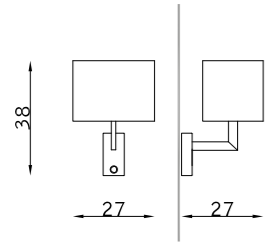

32365

1 x E27 46W

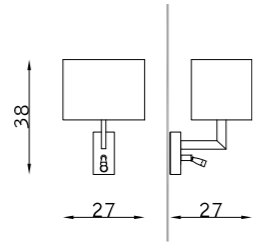

32366

1 x E27 46W +  
LED 1 x 1,4W 3.000°K - 350mA

TAVOLO TABLE

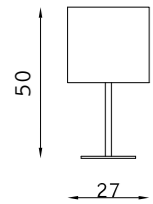

32367

1 x E27 46W

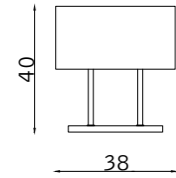

32369

1 x E27 46W

TERRA FLOOR

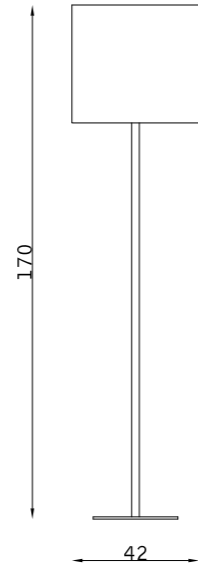

32368

1 x E27 77W

## RIGORE

Lampada in metallo disponibile nelle combinazioni cromo (102) con paralume liscio bianco (800) oppure cromo nero (104) con paralume liscio beige (027), oppure in altri colori a scelta.

*Metal lamp available in the combinations chrome (102) with white (800) smooth lampshade or black chrome (104) with beige (027) smooth lampshade, or in other colors of your choice.*



# RIGORE

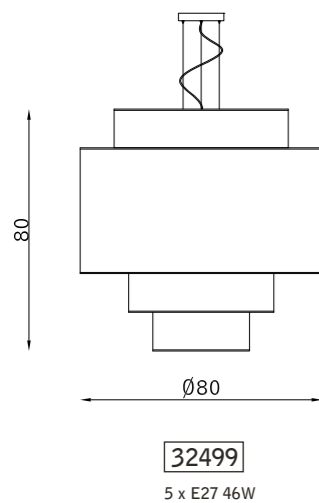
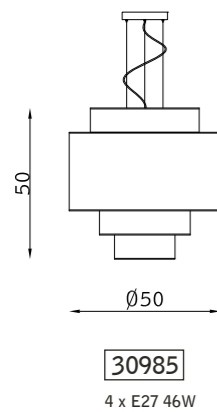

## TORRE

Lampada composta da tre paralumi cilindrici lisci di diverse dimensioni disponibili in color avorio (881) abbinato alla meccanica in finitura cromo (102) oppure in color caramello (869) abbinato alla meccanica in finitura ottone lucido (106).

*Lamp composed of three smooth cylindrical lampshades of different sizes available in ivory color (881) combined with the mechanics in chrome finish (102) or in caramel color (869) combined with the mechanics in polished brass finish (106).*



# TORRE

TAVOLO TABLE

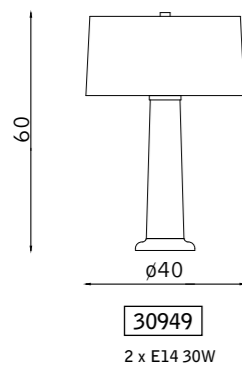

TERRA FLOOR

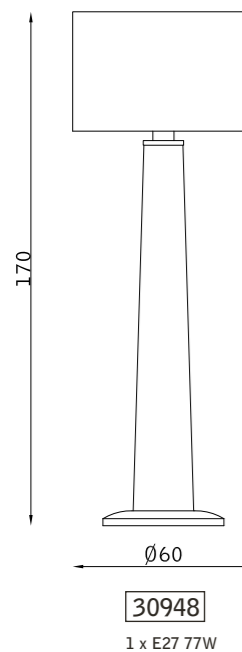

**MONACO** Design Pierre Yves-Rochon

Lampade con colonna centrale in legno finitura noce (70), parte meccanica in bronzo scuro (127), paralume liscio avorio (886) e diffusore interno in vetro bianco satinato.

*Lamps with central column in walnut finish wood (70), mechanical part in dark bronze (127), ivory (886) smooth lampshade and internal diffuser in white satin glass.*

MONACO

# MATERIALS

BRASS

ALUMINUM

IRON

GLASS

WOOD

TEXTILE

CERAMIC

## CLASSICO | CLASSIC

finitura e coloritura dei metalli | surface finishes and colours of metal



126  
bronzo chiaro  
light bronze



101  
nickel satinato  
satin nickel



103  
nickel lucido  
polished nickel



127  
bronzo scuro  
dark bronze



108  
oro francese lucido  
french polished gold



102  
cromo lucido  
polished chrome



105  
oro zecchino  
24 KT gold



120  
ottone satinato  
satin brass



106  
ottone lucido  
polished brass



111  
oro francese  
french gold



125  
bronzo arte  
art bronze



145  
oro  
gold

## MODERNO | MODERN

finitura e coloritura dei metalli | surface finishes and colours of metal



190  
bianco opaco  
matt white



187  
sabbia  
sand



151  
alluminio  
aluminum



127  
bronzo scuro  
dark bronze



131  
marrone opaco  
matt brown



191  
nero opaco  
matt black

## PARALUMI | LAMPSHADES

colori e finiture dei paralumi | lampshades colours and finishings



000 nero liscio  
000 smooth black



nero liscio 000IO  
(interno oro)  
smooth black 000IO  
(gold inside)



003 bianco plissé  
003 white pleated



023 bordeaux plissé  
023 bordeaux pleated



024 avorio plissé  
024 ivory pleated



027 beige liscio  
027 smooth beige



036 bianco lana  
fasciato  
036 wrapped  
wool white



063 grigio  
063 grey



083 avorio plissé  
083 ivory pleated



088 plissé avorio  
088 ivory pleated



090 bianco fasciato  
090 wrapped white



094 nero plissé  
094 black pleated



095 marrone fasciato  
095 wrapped brown



233 verde acido liscio  
233 smooth acid green



349 fucsia liscio  
349 smooth fuchsia



424 bianco liscio  
424 smooth white



459 avorio liscio  
459 smooth ivory



489 turchese  
liscio  
489 smooth  
turquoise



503 plissé avorio  
503 ivory pleated



554 beige liscio  
554 smooth beige



568 tabacco liscio  
568 smooth tobacco



800 bianco liscio  
800 smooth white



803 avorio liscio  
803 smooth ivory



826 pesca liscio  
826 smooth  
peach rose



869 cammello liscio  
869 smooth camel

## LES GRANDS CLASSIQUES - JACQUES GARCIA

finition métal - surface finishes of metal - finiture dei metalli



bronze  
doré  
135



bronze  
vieil  
antiquaire  
136



chrome  
102

## les abat-jours - the lamp shades - i paralumi



ivoire  
701



093



noir  
704



093B



rouge  
théâtre  
707



094

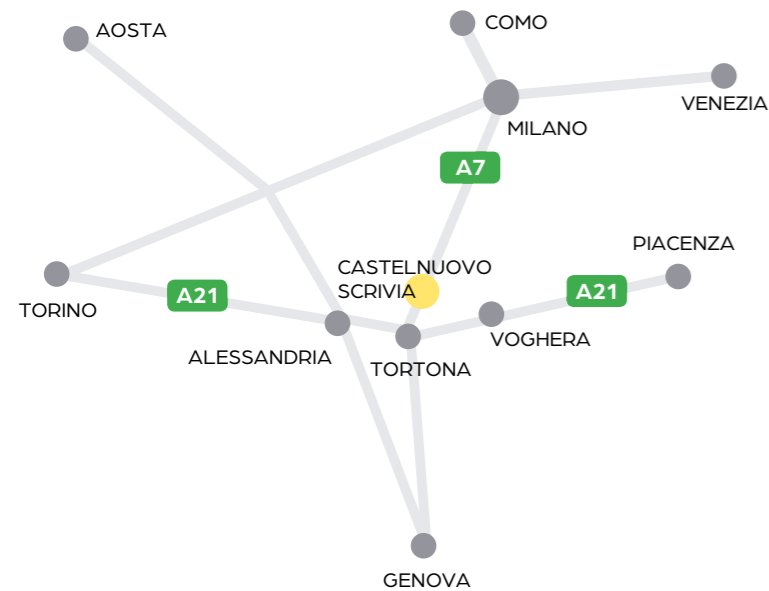

#### COME RAGGIUNGERCI

Dall'autostrada A7 (MI/GE) uscita Castelnuovo Scivia.

Dall'autostrada A21 (TO/PC) uscita Voghera, seguire direzione Castelnuovo Scivia.

#### HOW TO REACH US

*From the A7 highway (Milan/Genoa)*

*"Castelnuovo Scivia" exit.*

*From the A21 highway (Turin/Piacenza)*

*"Voghera" exit, follow road markings to*

*"Castelnuovo Scivia".*

#### ZONCA LIGHTING Srl

Headquarter

Via Berri 2/4

Castelnuovo Scivia (AL)

Italia

tel. + 39 0131 1716750

[www.zoncalighting.it](http://www.zoncalighting.it)

[info@zoncalighting.it](mailto:info@zoncalighting.it)

revisione e stampa

Acube srl

Novembre 2021

Nella continua ricerca di miglioramenti tecnici e funzionali, Zonca Lighting si riserva il diritto di apportare modifiche anche sostanziali ai propri prodotti, che potranno essere effettuate senza preavviso. Disegni, quote e colori sono da intendersi a titolo puramente indicativo e non impegnano Zonca Lighting. Il presente catalogo è tutelato dalla legge sul diritto d'autore - legge 22/4/1941 n.633 e R.D. 14/12/1942 n. 1485 e successive modificazioni e integrazioni nonché delle leggi, regolamenti e decreti attuativi.

È proibita ogni riproduzione totale o anche parziale.

I prodotti Zonca Lighting sono conformi a tutte le direttive loro applicabili.

In order to ensure continual technical and functional improvement, Zonca Lighting reserves the right to make minor or significant changes to its products, which may be introduced without prior notice. Designs, dimensions and colours are for indicative purposes only and are not binding for Zonca Lighting. This catalogue is protected by copyright law - Law no. 633 of 22/4/1941 and R.D. no. 1485 of 14/12/1942, as amended, as well as by current laws, regulations and decrees.

Reproduction in whole or in part is prohibited.

Zonca Lighting products comply with all applicable legislation.





[www.zoncalighting.it](http://www.zoncalighting.it)